

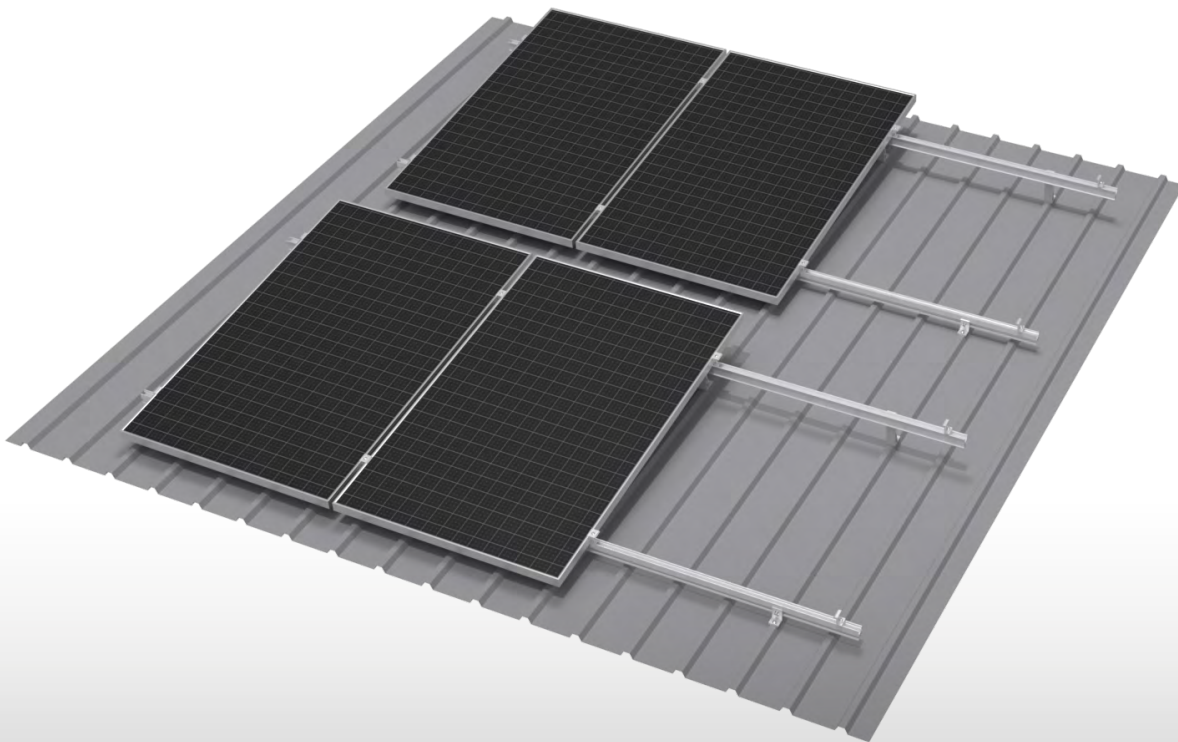

Designed for the Australia

# L-Profile 5 Degree Tilt Legs

Code-Compliant Planning and Installation Guide V 1.1  
Complying with AS/NZS1170.2-2021



# Introduction

The Clenergy PVezRack® SolarRoof™ has been developed as a universal PV-mounting system for roofmounting on pitched and flat roofs. L-Profile 5 Degree Tilt Legs are another innovative Tin roof interface. L-Profile 5 Degree Tilt Legs are designed to enable PV modules (in portrait) to achieve a 5 - degree tilt angle with the most cost-effective and simple way.

Prior to installing the PVezRack® SolarRoof™ system, it is essential to review this manual. This manual provides:

1) Supporting documentation for building permit applications relating to PVezRack® SolarRoof™ Universal PV Module Mounting System.

## List of contents

Introduction	01
Planning	02 - 03
Tools & Components	04
System Overview	05 - 06
Installation Instruction	07 -10
Certification	11

The PVezRack® SolarRoof™ parts, when installed in accordance with this guide, will be structurally sound and will meet the AS/NZS1170.2:2021 standard. During installation, and especially when working on the roof, please comply with the appropriate Occupational Health and Safety regulations. Please also pay attention to any other relevant State or Federal regulations. Please check that you are using the latest version of the Installation Manual, which you can do by contacting Clenergy Australia via email at [tech@clenergy.com.au](mailto:tech@clenergy.com.au) or contacting your local distributor in Australia.

### Product Warranty:

Please refer [PVezRack® Product Warranty](#) on our website.

### The installer is solely responsible for:

- Complying with all applicable local or national building codes, including any that may supersede this manual.
- Ensuring that PV-ezRack and other products are appropriate for the installation and the installation environment.
- Using only PV-ezRack parts and installer-supplied parts as specified by the PV-ezRack project plan. (substitution of parts may void the warranty and invalidate the letter of certification).
- Recycling: Recycle according to the local relative statute.
- Removal: Reverse installation process.
- Ensure that at least two professionals are engaged in panel installation.
- Ensure the installation of related electrical equipment is performed by licensed electricians.
- Ensuring safe installation of all electrical aspects of the PV array. This includes adequate earth bonding of the PV array and PV-ezRack® SolarRoof™ components as required in AS/NZS 5033-2021.
- Ensuring that the roof, its rafters/purlins, connections, and other structural support members can support the array under building live load conditions. Ensuring that screws to fix interfaces have adequate pull-out strength and shear capacities as installed. Maintaining the waterproof integrity of the roof, including the selection of appropriate flashing. Verifying the compatibility of the installation considering preventing electrochemical corrosion between dissimilar metals. This may occur between structures and the building and between structures, fasteners and PV modules, as detailed in AS/NZS 5033: 2021.
- Verifying atmospheric corrosivity zone of installation site by referring to AS 4312: 2019 or consulting local construction business to determine appropriate products and installations.

# Planning

Determine the wind region of the installation site

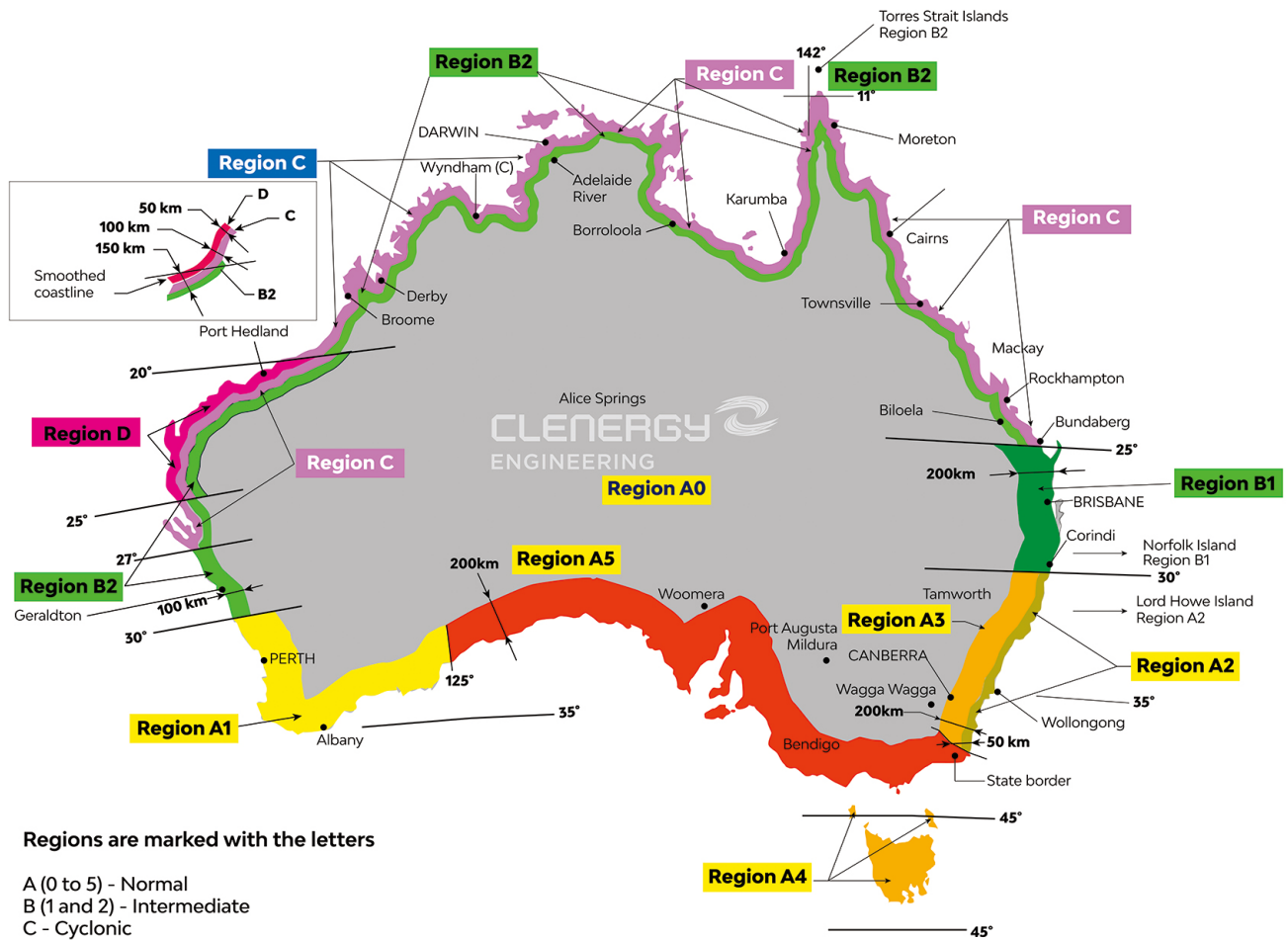

Wind Regions – Australia

Wind regions across Australia are defined by the Australian Standard AS 1170.2:2021. Compared to the 2011 version, the 2021 update includes significant changes to the wind region classifications.

- Central Australia is now classified as Wind Region A0 and Terrain Classification 2 instead of Wind Region A4
- Region A1, which previously covered most of Australia's South Coast, is now divided into Regions A1 and A5.
- Region B has been divided into regions B1 and B2. This will affect installations in Northern NSW, Gold Coast, Brisbane, Sunshine Coast, and Gladstone.
- Region B1 now includes more inland cities around Brisbane. This may require additional structural considerations, such as installing extra rails.

## Determine the Terrain Category

You will need to determine the terrain category to ensure the installation meets the required standard. Terrain Category 1 (TC1) refers to highly exposed open terrain with very few or no obstructions, as well as all water surfaces. Examples include flat, treeless, sparsely - grassed plains; open oceans, rivers, canals, bays, and lakes." , "Very exposed

Terrain Category 2 (TC2) – Open terrain, including grassland, with well-scattered obstructions having heights generally from 1.5m to 5m, with no more than two obstructions per hectare, e.g. farmland and cleared subdivisions with isolated trees and uncut grass.

Terrain Category 2.5 (TC2.5) – Terrain with some trees or isolated obstructions, terrains in developing outer urban areas with scattered houses, or larger acreage developments with more than two and less than 10 buildings per hectare.

Terrain Category 3 (TC3) – Terrain with numerous closely spaced obstructions having heights generally from 3m to 10m. The minimum density of obstructions shall be at least the equivalent of 10 house-size obstructions per hectare, e.g. suburban housing, light industrial estates or dense forests.

Terrain Category 4 (TC4) – Terrain with numerous larger, high (10m to 30m tall) and closely-spaced constructions buildings, such as large city centers and well-developed industrial complexes.

If the installation site does not fall within Terrain Category 2, 2.5, or 3, it is necessary to contact Clenergy to obtain a project - specific engineering certificate to support the installation.

## Verify Atmospheric Corrosivity Zone of Installation Site

Please refer to “AS 4312: 2019 Atmospheric Corrosivity Zones in Australia” or consult local construction business to verify corrosivity category of installation site.

Note: Clenergy provided screws for Tin interfaces are suitable for up to C5 corrosive environments only.

## Determine the Height of the Installation Site

This document provides sufficient information for the PV-ezRack® SolarRoof™ system installation up to heights of 30 meters. If the installation site is more than 30 meters high, please contact Clenergy to obtain a project-specific engineering certificate to support the installation.

## Determine the Installation Area of Roof

Please refer to the generic notes of the Certification Letter to determine the installation area based on building height, length, and width. Please be aware that under certain building conditions there is an Exclusion Zone for flush installation, which is the minimum distance between PV solar panel and roof edge of "2 x s", where "s" is the gap between the underside of the panel and the roof surface.

## Determine the Maximum Rail Support Spacing

Please refer to the Certification Letter and Interface Spacing Table. If a project-specific Certification Letter has been provided, please refer to the support spacing in this letter.

## Verify Maximum Rail End Overhang





Rail end overhang is defined as the distance from the last interface to the end of the panel. The maximum rail end overhang is 40% of the last interface installed spacing. For example, if the max interface spacing in the generic engineering certificate is 1200 mm and installed spacing is 1000 mm, the maximum rail end overhang is 400 mm.

## Acquire PV Modules Clamping Zone Information









It is important to check PV modules clamping requirements (e.g, clamp dimensions and clamping distance from the end of the panel) with the manufacturer before installations. This ensures the correct clamp size is used and aids in planning the interface positions on the roof, as well as the orientation and placement of the rails.

# Tools and Components

## Tools

				
<b>Screw Driver</b> (maximum torque ≥ 34N·m)	<b>Torque Spanner</b>	<b>3/8" Hex Socket</b>	<b>5m Tape</b>	<b>String &amp; Marker Pen</b>

## Components

				
<b>ER-R-ECO</b> ECO Rail	<b>ER-R-ELT</b> Elite Rail	<b>ER-SP-ECO</b> Splice for ECO Rail	<b>ER-SP-ELT</b> Splice for Elite Rail	<b>ER-CAP-ELT/ECO</b> Cap for Elite and ECO Rail
				
<b>ER-TL-5/L/C5</b> L-Profile 5 Degree Tilt Legs with Climaseal 5 (C5) Screws	<b>ER-I-09</b> Klip lok Interface 400-700HS	<b>ER-I-34</b> Brooklyn Klip-lok Clamp	<b>ER-I-32/AU</b> Klip-lok Interface 406 with U-opening for Clenergy AU	<b>ER-I-29/AU</b> Klip-lok Interface for longline 305, for Clenergy AU

# System Overview

## Overview of L-Profile 5 Degree Tilt Legs Penetrative solution

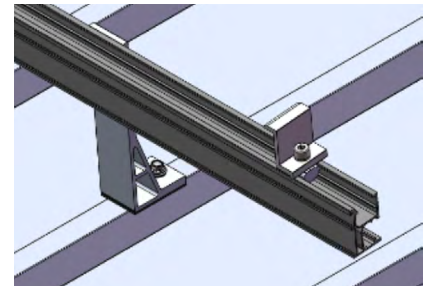
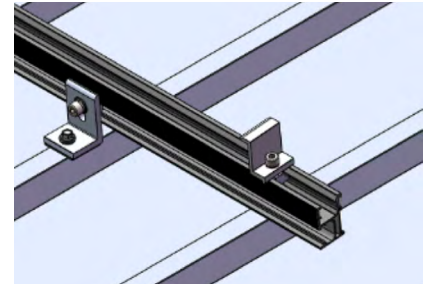

A. End Clamp    B. Inter Clamp    C. ECO/Elite Rail    D. Rear leg    E. Front leg

## Overview of L-Profile 5 Degree Tilt Legs Non-penetrative solution

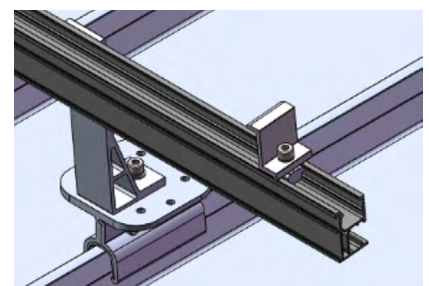
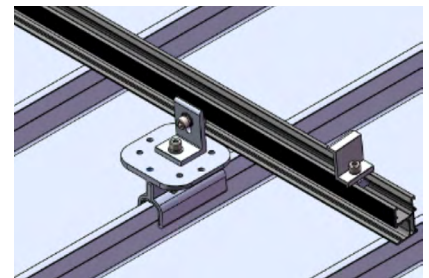
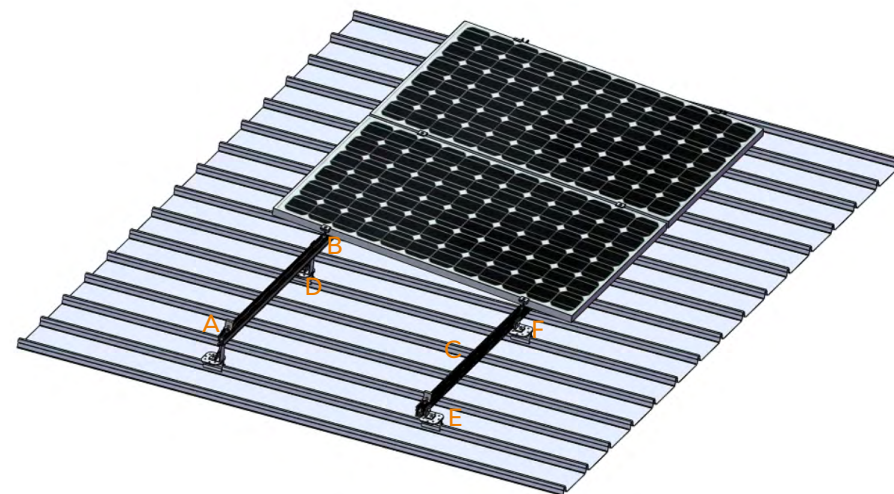

A. End Clamp    B. Inter Clamp    C. ECO/Elite Rail    D. Rear leg    E. Front leg    F. Kliplok interface

## Precautions during Stainless Steel Fastener Installation

Improper operation may lead to the deadlock of Nuts and Bolts. The steps below should be applied to stainless steel nut and bolt assembly to reduce this risk.

### General installation instructions:

- (1) Apply force to fasteners in the direction of the thread
- (2) Apply force uniformly, to maintain the required torque
- (3) Professional tools and tool belts are recommended
- (4) In some cases, fasteners could be seized over time. To prevent galling or thread seizing, apply lubricant (such as grease or 40# engine oil) to the fasteners before tightening.

### Safe Torques:

Please refer to the safe torques values specified in this guide, as shown in the figures below. If power tools are required, Clenergy recommends using low speed only. High speed tools and impact drivers increase the risk of bolt galling (deadlock). If deadlock occurs and fasteners need to be cut, ensure there is no load on the fastener before cut. Avoid damaging the anodized or galvanized surfaces.

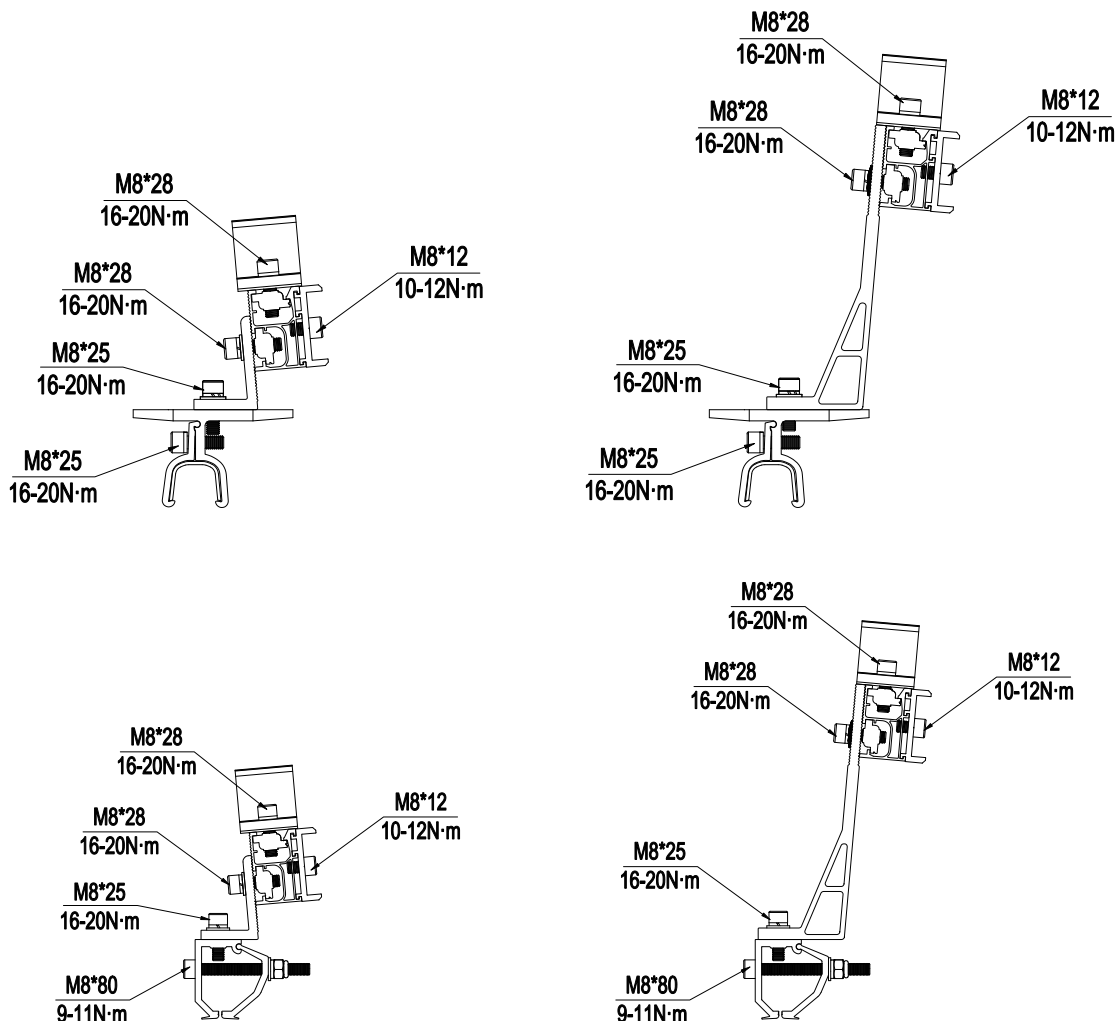

# Installation Instructions

## Penetrative Installation

Position the L-Profile 5 Degree Tilt Legs correctly on the rib of the roof accordingly to the layout plan, and press the bracket down to ensure the EPDM pad on each side makes proper contact with the roof rib. Once positioned, release the L-Profile 5 Degree Tilt Legs after installing 1 screw.

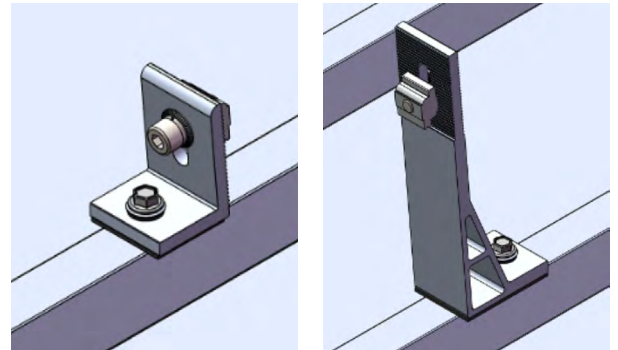

Screw installation instruction:

1. Use a 3/8" Hex Socket.
2. Use a mains-powered or cordless screwdriver with a maximum drive speed of 3,000 RPM.
3. Fit the driver bit into the screw and place it at the fastening position.
4. Apply consistently firm pressure (end load) to the screwdriver until the screw has fastened.

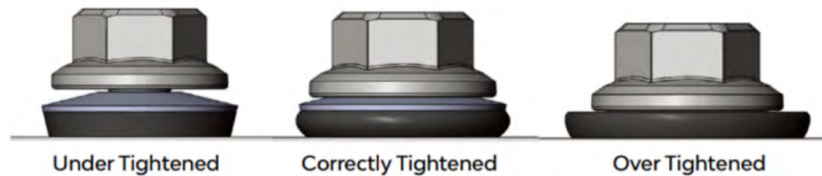

Note:

Screws that are not exposed to frequent rain should be washed down with fresh water at least every 6 months to meet the warranty conditions of Buildex Screws.

## Non-penetrative Installation

According to the installation plan, determine the mounting position and orientation of the Kliplok Interface and L-Profile 5 Degree Tilt Legs depending on rails running parallel or perpendicular to the roof rib, then fasten the bolt with 16-20 N·m torque.

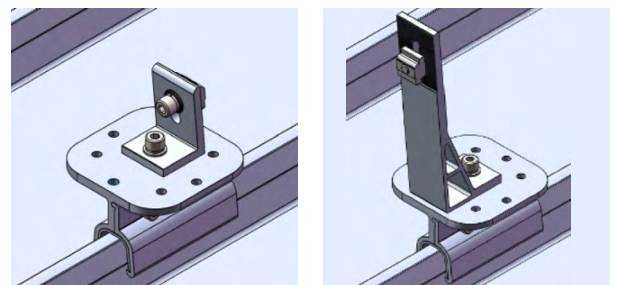

Installation with ER-I-09

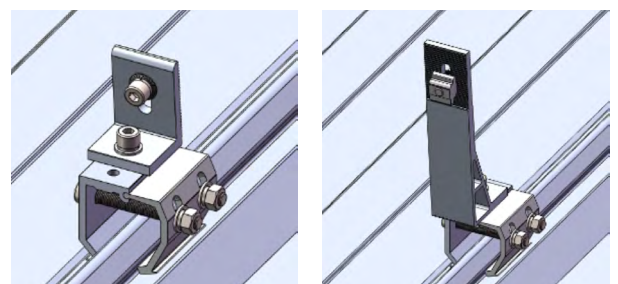

Installation with ER-I-34

Note:

Screws that are not exposed to frequent rain should be washed down with fresh water at least every 6 months to meet the warranty conditions of Buildex Screws.

## Rail Installation

### When connecting ECO rails:

To connect multiple rails, sliding half of the splice into the rear side of the rail, and fasten the first M8 bolt. Slide the next rail into the splice and tighten the second M8 bolt. Splice provides the electrical connection between the 2 rails through the pressure bolts. This eliminates the need of using 2 earthing lugs.

Required torque is 10 ~12 N.m.

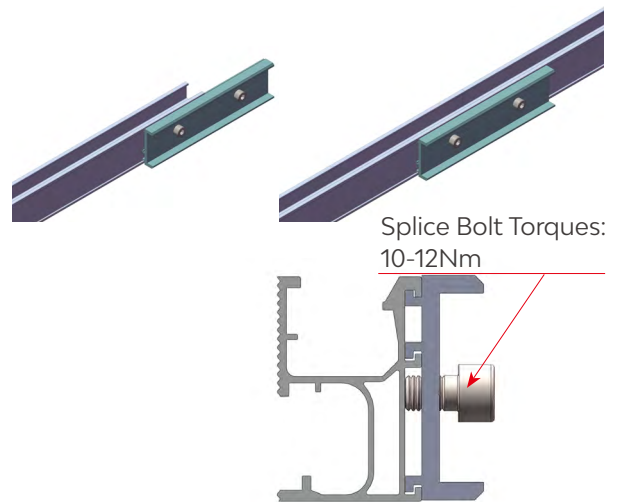

ECO-Rail, installation with ECO rail splice

### When connecting Elite rails:

- Option 1: Using Elite Rail Splice (ER-SP-ELT)

To connect several rails together, slide half of the splice into the rear side of the rail. The connection clip of splice can make selflocking with the rail without using any tool. Slide the next rail into the splice to complete two rails connection. The sharp teeth of connection clip of splice can provide the earthing continuity between two rails. This eliminates the need of using 2 grounding lugs

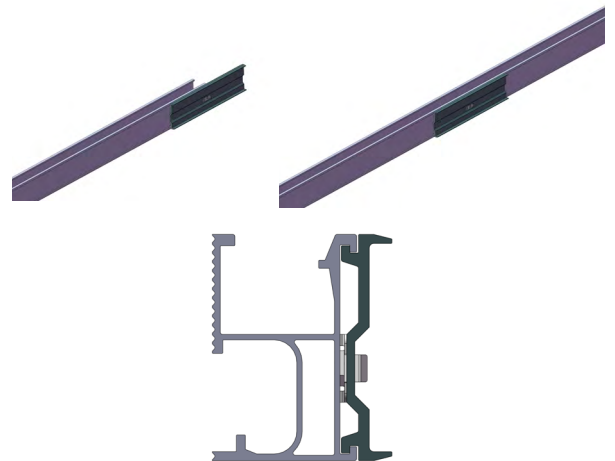

Elite-rail installation with Elite rail splice

In case of requiring rails cutting to be joined by Elite rail splice, please make sure cutting as straight as possible to avoid splice clip teeth mistouching rails. It is because after installation it is just 3.4 mm from the rail end to the clip teeth as shown in the diagram.

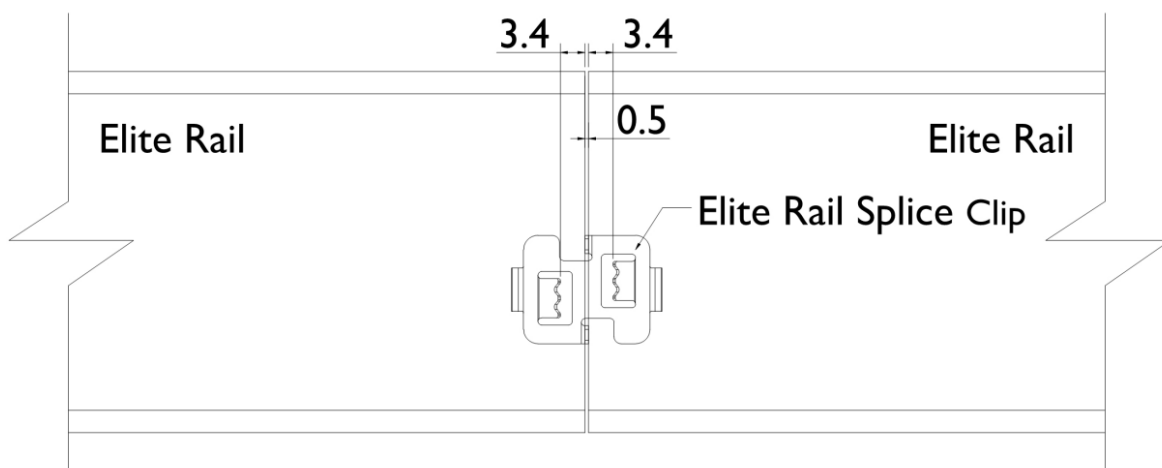

• Option 2: Using ECO Rail Splice (ER-SP-ECO)

ECO rail splice can be used for connecting Elite rails. To connect several rails together, slide half of the splice into the rear side of the rail. Fasten the first M8 bolt with torque of 2 ~ 4 N.m and slide the next rail into the splice and fasten the second M8 bolt with torque of 2 ~ 4 N.m. The low torque is not to impact the structural integrity of the system as the defined 2 ~ 4 N.m. Torque is sufficient to secure the required positioning of the splice for the design life of the system, and can provide the earthing continuity between two rails through the bolts and splice. This eliminates the need of using 2 grounding lugs.

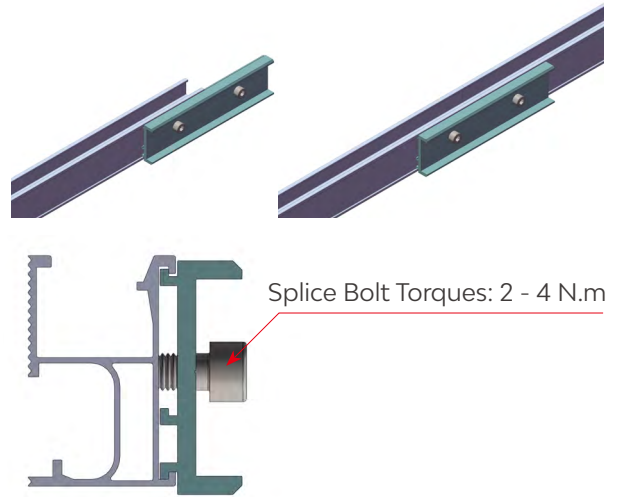

Elite-rail installation with ECO rail splice

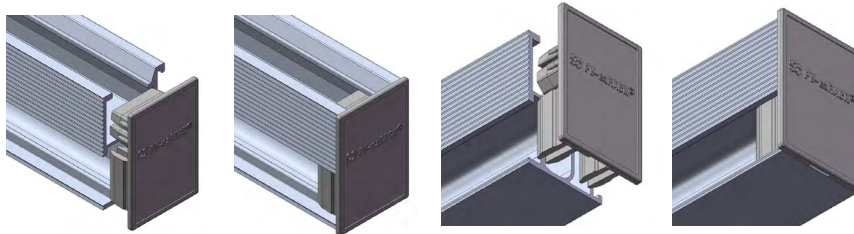

When installing Elite rail end cap, align the cap with the end of the Elite rail and firmly press and secure it in place.

For installations using ER-I-09 or ER-I-34. Install the Z module into the side channel of ECO Rail or Elite Rail as shown in the figure below.

Installation with ER-I-09:

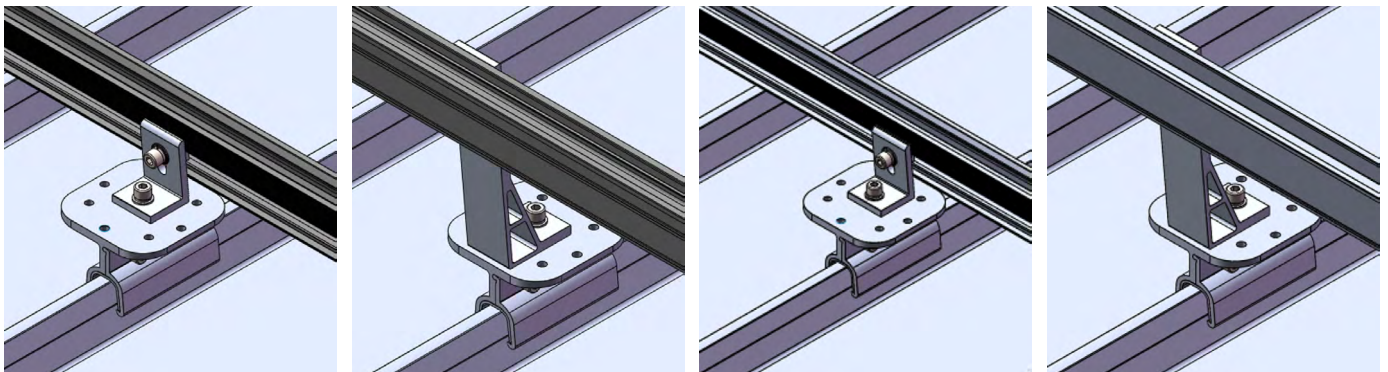

Installation with ECO Rail Installation with ER-I-34:

Installation with Elite Rail

Installation with ER-I-34:

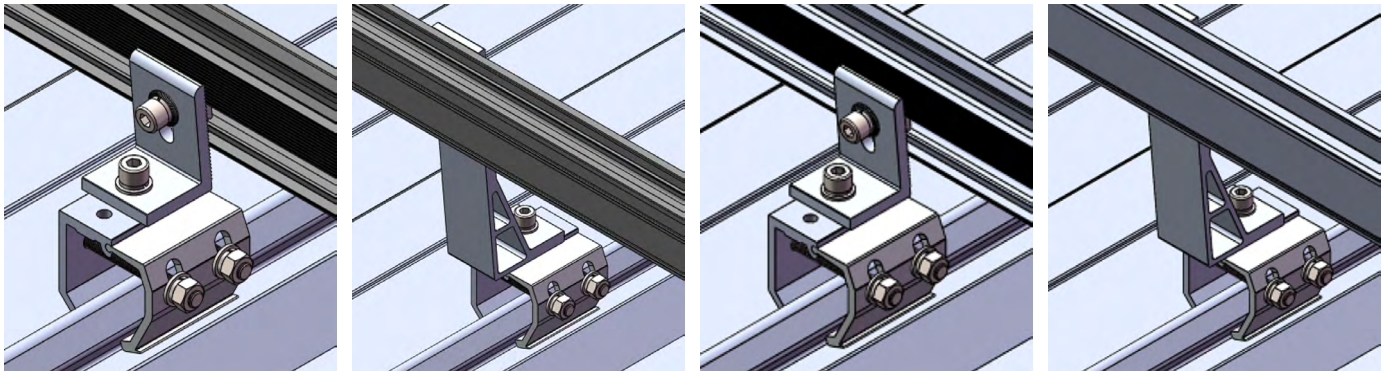

Installation with ECO Rail

Installation with Elite Rail

## Span installation range

When installation angle is 5.0°, the span adjustment range is 1262-1607mm.

With clearance < 1.0mm, the span adjustment range is 997-1983mm, the angle range is 3.6°-6.4°.

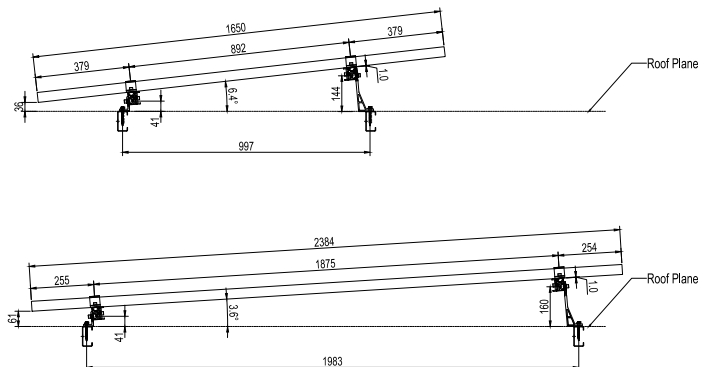
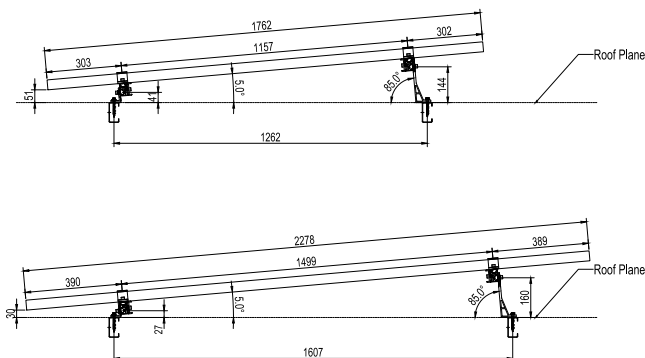

## PV Module Installation

Please refer to the [PVezRack® Grounding System](#) Installation Guide for PV modules clamps and grounding lugs installations.

The installers must ensure panel clamps are installed flush mounted to the panel frame and apply the correct torque value of the clamp fastener as shown in this guide.

# Certification



Clenergy Australia  
3/10 Duerdin Street  
Clayton, VIC 3168

**CIVIL & STRUCTURAL ENGINEERS**  
RESIDENTIAL - INDUSTRIAL - COMMERCIAL - PRODUCT DEVELOPMENT  
info@mwengineering.melbourne  
Phone: 1300 MWENG-0 (1300 69364-0)  
www.mwengineering.melbourne  
ABN 37 605 815 585

Date: 25 / 11 /2024

## ER-TL-5/L/C5 and ER-TL-5/L/C5/BA CERTIFICATION LETTER

MW Engineering Melbourne, being Structural Engineers within the meaning of Australian regulations, have assessed and certified the ER-TL-5/L/C5 and ER-TL-5/L/C5/BA components to be used with the following documents:

Ref. Number	Certificate
CL-406-S	Klip-lok Tilt Interface spacing tables
CL-530-S	Penetrative Tilt Interface spacing tables
CL-1168-Y	Penetrative Flush and Tilt Interface (ELITE rails)
CL-1173-Y	Klip-lok Flush and Tilt Interface (ELITE rails)

The certificates will be valid unless an amendment is issued on any of the following codes:

- AS/NZS 1170.0- 2002 AMDT 4 2016      **General Principles**
- AS/NZS 1170.1- 2002 AMDT 4-2016      **Imposed Loadings**
- AS/NZS 1170.2- 2021      **Wind Loadings**
- AS/NZS 1664.1- 1997 AMDT 1:1999      **Aluminium Code**

Should you have any queries, do not hesitate to contact us.  
Best Regards,

Alberto Escobar  
Civil/Structural Engineer  
**BEng MIEAust NER**  
PE 0003615 RPEQ 18759 BDC 3134 BPB (NT) 262228ES BSP (TAS)  
845530344  
[info@mwengineering.melbourne](mailto:info@mwengineering.melbourne)

## Change History





No.	Version No.	Amendment Details	Author	Review	Approve	Date
1	1.0	First Issue	Jason	Cora	Shams	03/2025
2	1.1	Added Description of Span Installation Range	Charles	Shams	Shams	03/2026
3						



## Clenergy

3/10 Duerdin St  
Clayton VIC 3168  
Australia

Phone: +61 3 9239 8088  
Email: [sales@clenergy.com.au](mailto:sales@clenergy.com.au)  
Web: [www.clenergy.com.au](http://www.clenergy.com.au)

 @ClenergyGlobal / @ClenergyClub / ClenergyAUS  @Clenergy  @ClenergyClub  
 @Clenergy\_global  @Clenergy

A Clenergy Technologies Company