

## Zano End Clamp and Inter Clamp 28-42 mm, Length 50 mm

### Assembly

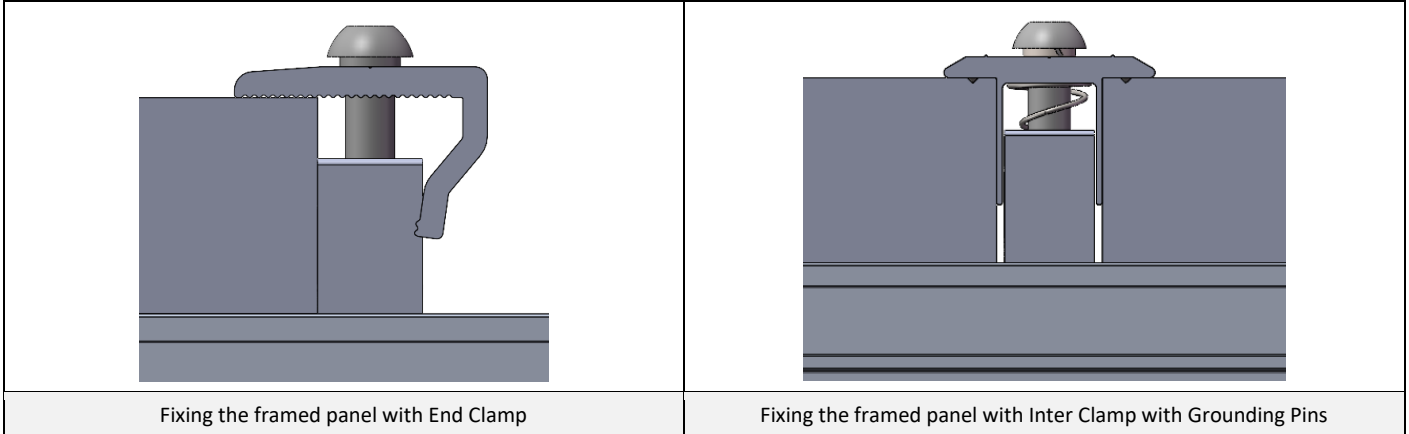

### Component

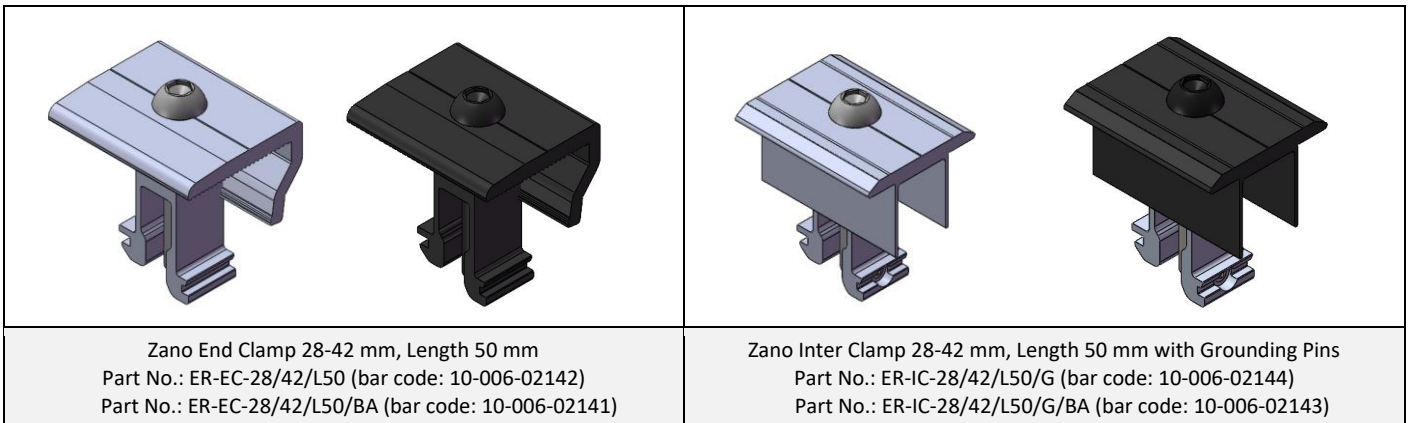

### Technical Specification

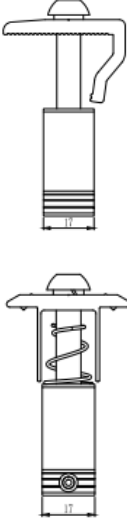
<b>Application</b>	for framed PV Modules of 28-42mm	
<b>Requirement</b>	Needs 20mm space between PV Modules	
<b>Recommended Torque</b>	13-16 N•m	
<b>Weight</b>	ER-EC-28/42/L50 and ER-EC-28/42/L50/BA: 0.076 Kg ER-IC-28/42/L50/G and ER-IC-28/42/L50/G/BA: 0.068 Kg	
<b>Packaging</b>	ER-EC-28/42/L50: 54 units per pack, 4 packs (216units) per carton ER-EC-28/42/L50/BA: 27 units per pack, 4 packs (108 units) per carton ER-IC-28/42/L50/G: 60 units per pack, 4 packs (240 units) per carton ER-IC-28/42/L50/G/BA: 27 units per pack, 4 packs (108 units) per carton	
<b>Material</b>	Main Structure: AL6005-T5 Fasteners: SUS 304	