

Splice for Elite Rail

Assembly

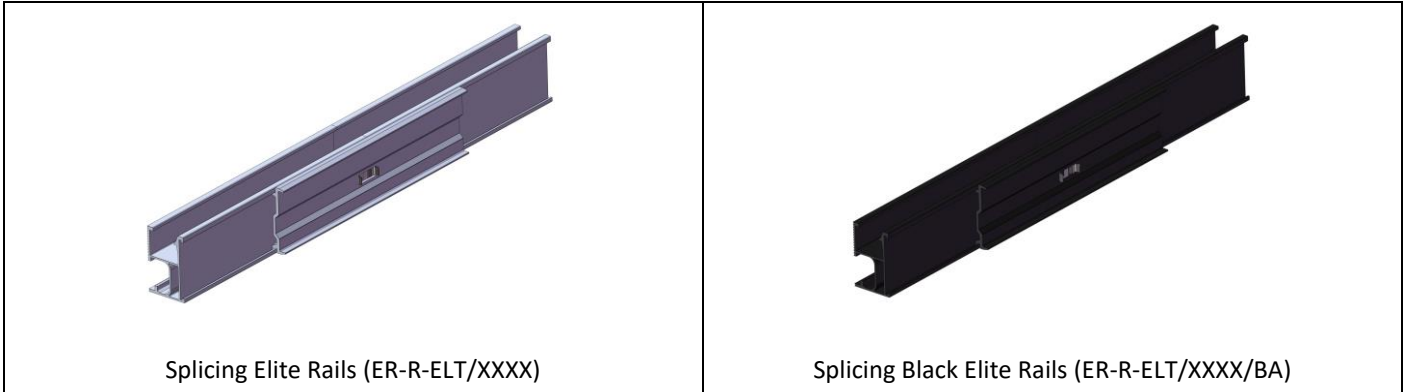

Component

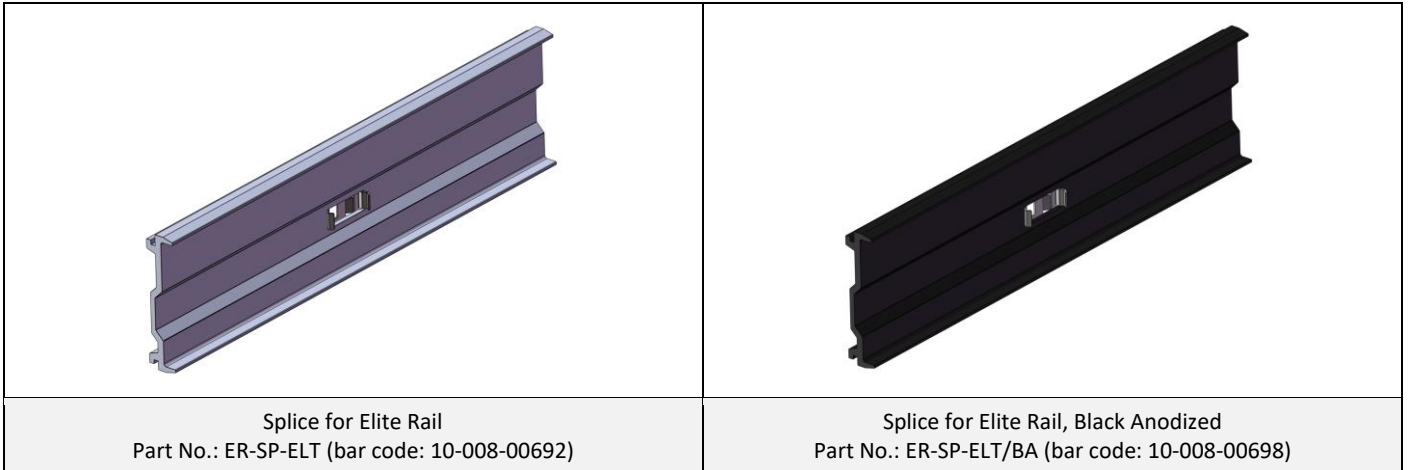

Technical Specification

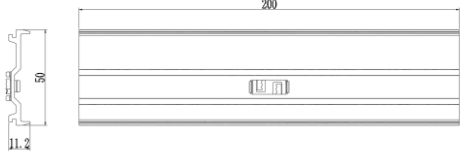
Application	Splicing Elite rails of PV-ezRack Mounting System	
Dimensions	L200mm*W11.2mm*H50mm	
Weight	0.086 Kg	
Packaging	60 units per pack, 4 packs (240 units) per carton, 60 cartons (14,400 units) per pallet	
Packaging Dimension	L397*W267*H345mm (carton dimension)	
Weight	ER-SP-ELT: 0.086 Kg; 21.86 Kg (carton weight) ER-SP-ELT/BA: 0.086 Kg; 21.86 Kg (carton weight)	
Material	Main part: AL6005-T5 Connection Clip: SUS304	
Finish	Anodized (no less than 10 μm, excluding machined surfaces)	
Standard	AS NZS1170.2-2021	