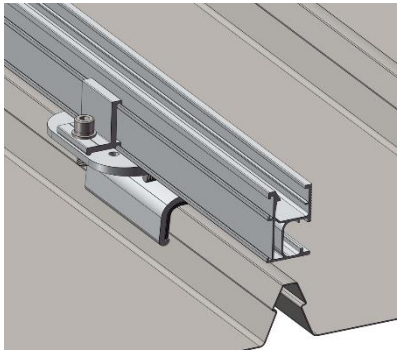
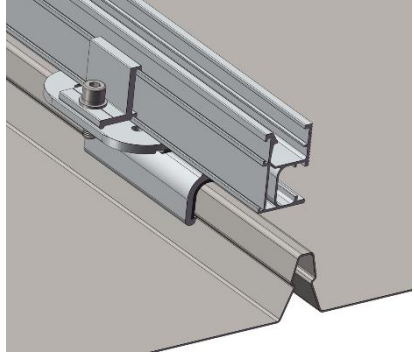
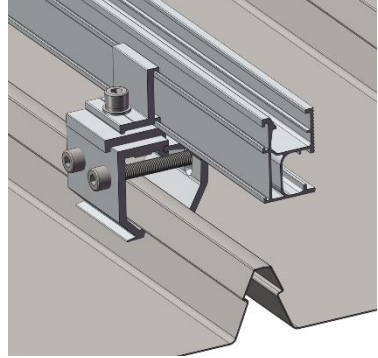
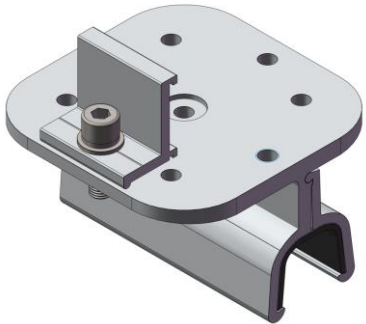
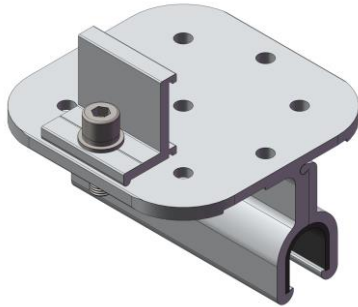
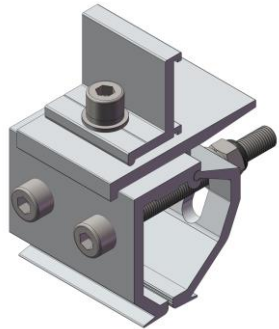

## Klip-lok Interface, pre-assembly with Cross Connector Clamp

### Assembly

		
ER-I-09/CRC	ER-I-32/CRC	ER-I-34/CRC/PT

### Component

		
<p>Klip-lok Interface 400-700HS, pre-assembly with Cross Connector Clamp Part No.: ER-I-09/CRC (bar code: 10-002-00625)</p>	<p>Klip-lok Interface 406, pre-assembly with Cross Connector Clamp Part No.: ER-I-32/CRC (bar code: 10-002-00626)</p>	<p>Brooklyn Klip-lok Clamp pre-assembly with Cross Connector Clamp and Plate Kit Part No.: ER-I-34/CRC/PT (bar code: 10-002-00627)</p>

## Technical Specification

<b>Fixing Method</b>	Rails running parallel to roof ribs
<b>Dimensions</b>	ER-I-09/CRC: L100mm*W100mm*H96.6mm ER-I-32/CRC: L100mm*W100mm*H93.2mm ER-I-34/CRC/PT: L60mm*W88mm*H96mm
<b>Weight</b>	ER-I-09/CRC: 0.398 kg ER-I-32/CRC: 0.345 kg ER-I-34/CRC/PT: 0.279 kg
<b>Packaging</b>	ER-I-09/CRC: 20 units per pack, 2 packs (40 units) per carton ER-I-32/CRC: 20 units per pack, 2 packs (40 units) per carton ER-I-34/CRC/PT: 12 units per pack, 4 packs (48 units) per carton
<b>Material</b>	Main parts: AL6005-T5 Fasteners: SUS 304; Rubber Pad: EPDM
<b>Color</b>	Silver
<b>Finish</b>	Anodized (no less than 10 μm, excluding machined surfaces)
<b>Standard</b>	AS NZS1170.2-2021

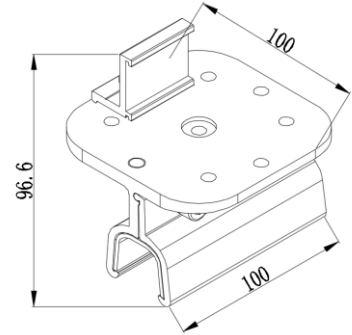

ER-I-09/CRC

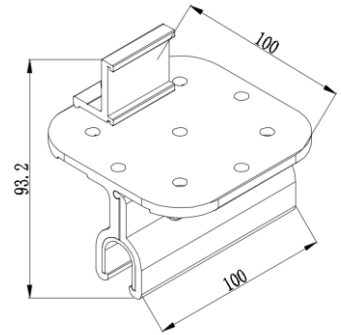

ER-I-32/CRC

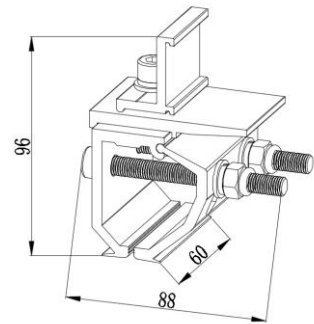

ER-I-34/CRC/PT