

SolarRoof

Code-Compliant Planning and Installation Guide V 2.0 (New Zealand)
Complying with AS/NZS 1170.2-2021



Contents

List of contents

Introduction	02
Planning	03 - 07
Determine the wind region of your installation site	03 - 05
Determine the Terrain Category	06
Verify Atmospheric Corrosivity Zone of Installation Site	06
Determine Building Dimension	06
Determine the Installation Area of Roof	07
Verify Rafter/Purlin Properties of Building	07
Determine the Maximum Rail Support Spacing	07
Verify Maximum Rail End Overhang	07
Acquire PV Modules Clamping Zone Information	07
Tools and Components	08 - 09
Tools	08
Components	08 - 09
System Overview	10 - 11
Overview of PVezRack® SolarRoof	10
Precautions during Stainless Steel Fastener Installation	11
General installation instructions	11
Safe Torques	11
Installation Instructions	12 - 18
Installation Dimensions	12
Tile Interface Installation	13
Rail Installation	14
PV Module Installation	15
Tin Interface Installation	15 - 17
Side Channel Cover for Cutter-Rail Installation (optional)	18
Hanger Bolt Installation	19 - 22
Hanger Bolt for Tile Roof Installation	19
Hanger Bolt for Tin Roof Installation	20 - 22
Engineering Certificate	23
Certificate User Guideline	46

Introduction

The Clenergy PVezRack® SolarRoof has been developed as a universal PV-mounting system for roof-mounting on pitched and flat roofs. The use of patented aluminium base rails, Z-Module technology and telescopic mounting technology eliminates custom cutting and enables fast installation.

Please review this manual thoroughly before installing PVezRack® SolarRoof. This manual provides:

- 1) Supporting documentation for building permit applications relating to PVezRack® SolarRoof Universal PV Module Mounting System,
- 2) Planning and installation instructions.

The PVezRack® SolarRoof parts, when installed in accordance with this guide, will be structurally sound and will meet the AS/NZS 1170.2 - 2021 standard. During installation, and especially when working on the roof, please comply with the appropriate Occupational Health and Safety regulations. Please also pay attention to any other relevant State or Federal regulations. Please check that you are using the latest version of the Installation Manual, which you can do by contacting Clenergy Australia via email on tech@clenergy.com.au, or contacting your local distributor in New Zealand.

The installer is solely responsible for:

- Complying with all applicable local or national building codes, including any updates that may supersede this manual;
- Ensuring that PVezRack® and other products are appropriate for the particular installation and the installation environment;

Product Warranty:

Please refer [PVezRack® Product Warranty](#) on our website.

- Using only PVezRack® parts and installer-supplied parts as specified by PVezRack® project plan (substitution of parts may void the warranty and invalidate the letter of certification);
- Recycling: Recycle according to the local relative statute;
- Removal: Reverse installation process;
- Ensuring that there are no less than two professionals working on panel installation;
- Ensuring the installation of related electrical equipment is performed by licenced electricians;
- Ensuring safe installation of all electrical aspects of the PV array, This includes adequate earth bonding of the PV array and PVezRack® SolarRoof components as required in AS/NZS 5033: 2021.
- Ensuring that the roof, its rafters/purlins, connections, and other structural support members can support the array under building live load conditions;
- Ensuring that screws to fix interfaces have adequate pullout strength and shear capacities as installed;
- Maintaining the waterproof integrity of the roof, including selection of appropriate flashing;
- Verifying the compatibility of the installation considering preventing electrochemical corrosion between dissimilar metals. This may occur between structures and the building and also between structures, fasteners and PV modules, as detailed in AS/NZS 5033: 2021.
- Verifying atmospheric corrosivity zone of installation site by referring to SNZ TS 3404:2018 or consulting local construction business to determine appropriate products and installations.

Planning

Determine the wind region of your installation site

Wind regions map below shows 4 different wind regions in New Zealand: NZ1, NZ2, NZ3 and NZ4.

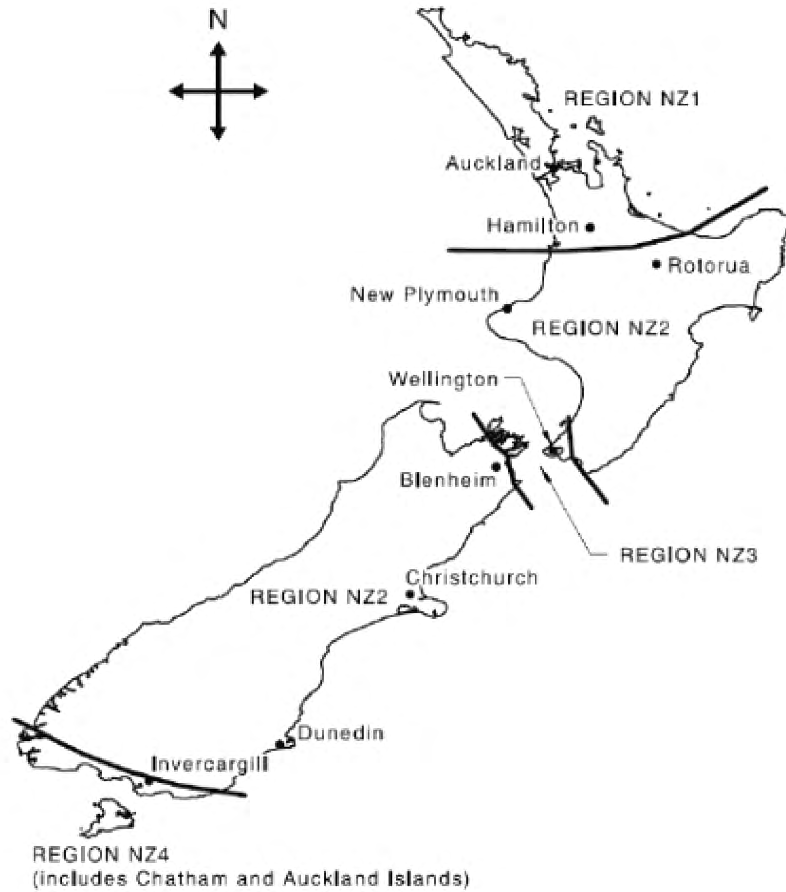

The lee (effect) multiplier (M_{1ee}) shall be evaluated for New Zealand sites in the lee zones below. In wind regions of NZ1 and NZ2 with M_{1ee} over 500 m above sea level, the interface spacing reduction is applied. Please refer to note 25 of engineering certificate.

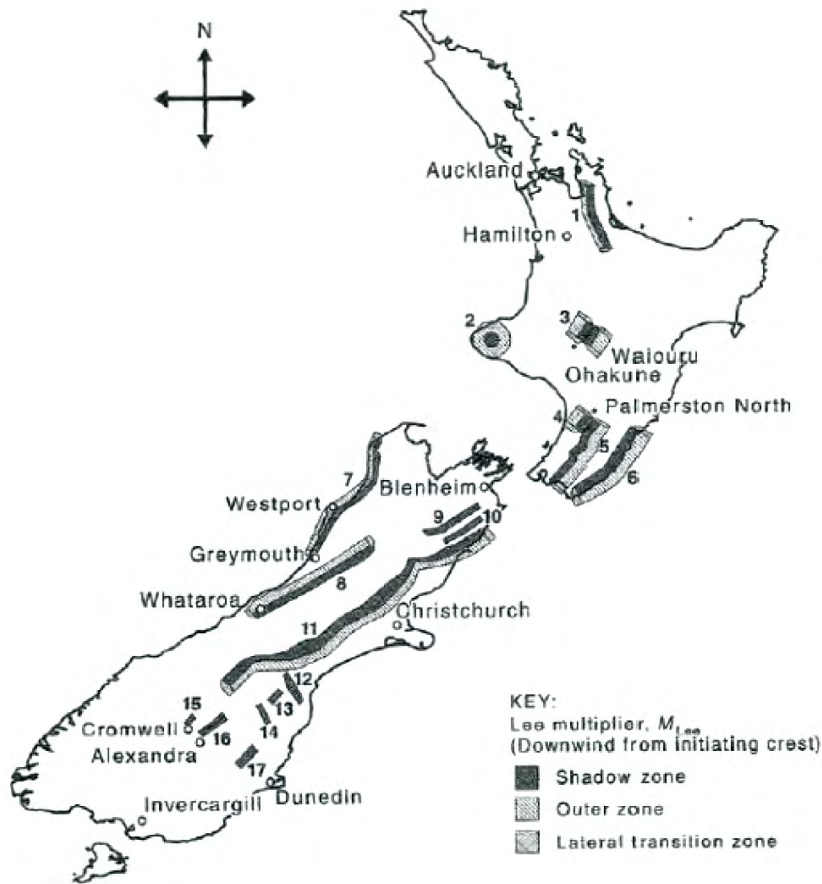

Locations of New Zealand lee Zones

For installation sites located in Sub-alpine Regions (shown on the map below), please refer to Note 26 of engineering certificate for maximum interface spacing and see "Examples" in certificate to understand how to use maximum spacing in Sub-alpine Regions.

If your installation site is in Alpine regions, please contact Clenergy to obtain a project specific engineering certificate to support your installation.

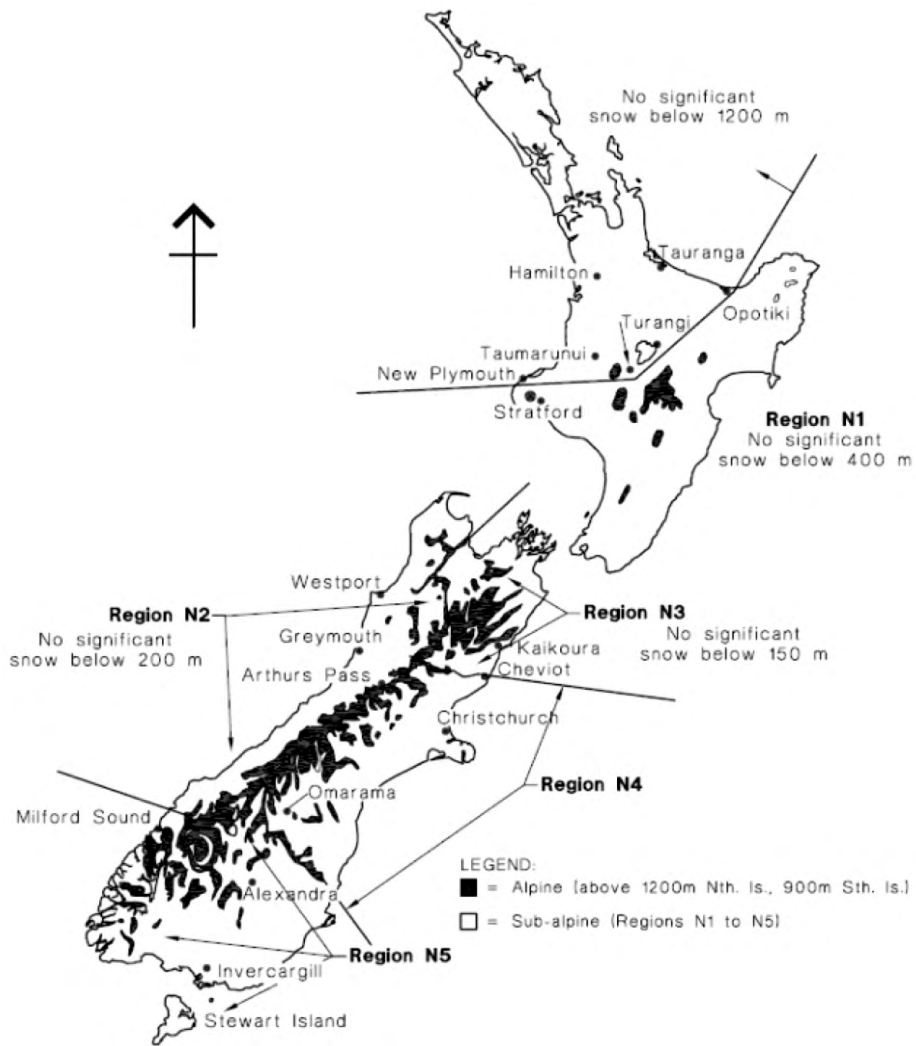

New Zealand – Approximate Locations of Alpine and Sub-alpine Regions

Determine the Terrain Category

It requires to determine the right terrain category to ensure the installation meets the maximum interface spacing specified in the engineering certificate.

Terrain Category 1 (TC1) – Very exposed open terrain with very few or no obstructions, and all water surfaces (e.g. flat, treeless, poorly grassed plains; open ocean, rivers, canals, bays and lakes).

Terrain Category 2 (TC2) – Open terrain, including grassland, with well-scattered obstructions having heights generally from 1.5 m to 5 m, with no more than two obstructions per hectare (e.g. farmland and cleared subdivisions with isolated trees and uncut grass).

Terrain Category 3 (TC3) – Terrain with numerous closely spaced obstructions having heights generally from 3 m to 10 m. The minimum density of obstructions shall be at least the equivalent of 10 house-size obstructions per hectare (e.g. suburban housing, light industrial estates or dense forests).

Terrain Category 4 (TC4) – Terrain with numerous large, high (10 m to 30 m tall) and closely spaced constructions, such as large city centres and well-developed industrial complexes.

If your installation site is not at TC 2 or 3, please contact Clenergy to obtain a project specific engineering certificate to support your installation.

Verify Atmospheric Corrosivity Zone of Installation Site

Please refer “SNZ TS 3404:2018 Durability Requirements for Steel Structures and Components” or consult local construction business to verify corrosivity category of installation site to determine appropriate corrosivity class roof interface screw.

Determine Building Dimension

This document provides sufficient information for the PVezRack® SolarRoof system installation up to 20 meters building height (average roof height of structure above the ground, see the diagram below). If your building is more than 20 meters high, please contact Clenergy to obtain project specific engineering certificate to support your installation.

Building horizontal dimensions (b and d) are required to calculate the ratio of h/d to determine maximum interface spacing.

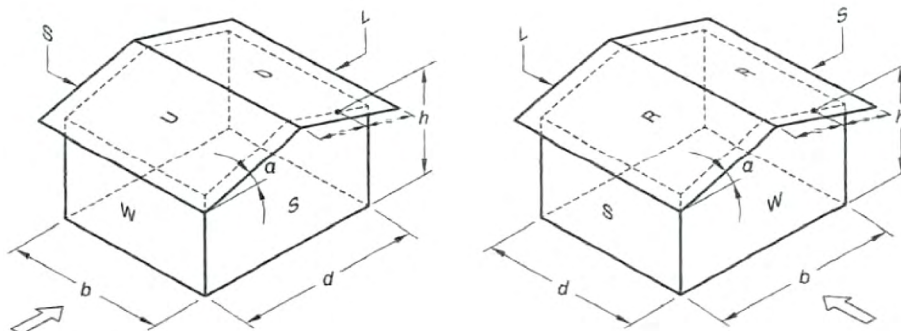

Parameters for Rectangular Enclosed Buildings

Determine the Installation Area of Roof

There are 4 different roof zones for tilt leg installation: Internal Zone, Intermediate Zone, Edge Zone and Corner Zone. Please see diagrams and steps below to define area of each zone.

Step 1. Determine building height (h), width (b) and length (d) – see diagram above;

Step 2. The lowest value between "b x 0.2" and "d x 0.2" is "a" if h/b or h/d > 0.2;

Step 3. "a" equates to 2h, If both h/b and h/d < 0.2,

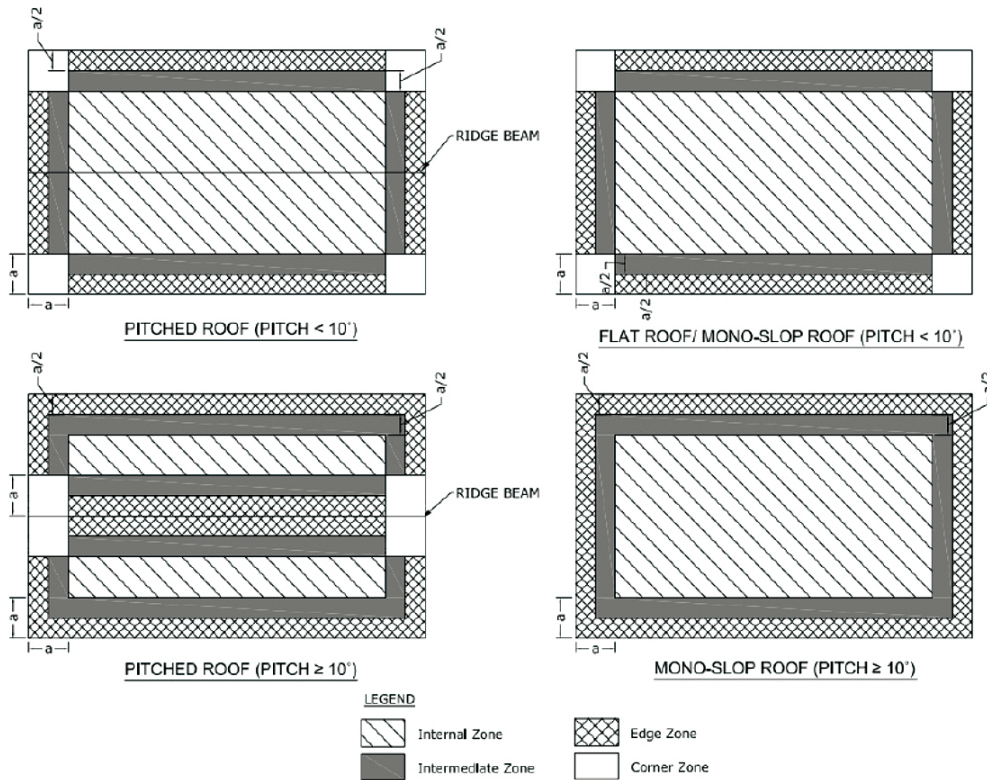

Roof Zones Definition

Verify Rafter/Purlin Properties of Building

Please verify rafter/purlin properties of building, which could affect the interface spacing. For example, tin interface spacing on the metal purlin in the certification letter is based on steel purlin G450 1.5 mm thick. If the steel purlin is less than 1.5 mm thick, the corresponding reduction factor of interface spacing will be applied. Please refer generic notes for details.

Determine the Maximum Rail Support Spacing

Please refer to the Certification Letter and Interface Spacing Table. If a project specific Certification Letter has been provided, please refer to the support spacing in this letter.

Verify Maximum Rail End Overhang







Rail end overhang should be not over 40% of the interface spacing. For example, if the interface spacing is 1500mm, the Rail end overhang can be up to 600mm only.

Acquire PV Modules Clamping Zone Information

It is recommended to acquire PV modules clamping zone info. from PV modules manufacturer, which can help to plan interfaces positions on the roof and rails orientation and positions.









Tools and Components

Tools

				
<p>Angle Grinder with Stone Disk</p>	<p>Screw Driver (for M8 Hexagon Socket Screw)</p>	<p>Torque Spanner</p>	<p>Spanner</p>	<p>5m Tape</p>
				
<p>String & Marker Pen</p>				

Components

				
<p>ER-EC-ST End Clamp</p>	<p>ER-IC-ST Inter Clamp</p>	<p>C-U/30/46-G Akashi Clamp with grounding clip</p>	<p>C-U/30/46 Akashi Clamp</p>	<p>ER-R-ECO ECO Rail</p>
				
<p>ER-SP-ECO Splice for ECO Rail</p>	<p>SCO-ECO/380 Side Channel Cover for Cutter-Rail, length 380 mm</p>			

 <p>ER-I-01 Tile Interface</p>	 <p>ER-I-01/CS Tile Interface, Galvanized Steel</p>	 <p>ER-I-01/EZC/ECO Tile Interface with ezClick connection for ECO-Rail</p>	 <p>ER-I-02 Flat Tile Interface</p>	 <p>ER-I-04 Slate Interface</p>
 <p>ER-I-23 Tile Interface -Landscape</p>	 <p>ER-I-26 Tile Interface -Side mount</p>	 <p>ER-I-51 Tile Interface, 118mm horizontal arm</p>		

 <p>ER-I-05 Tin Interface</p>	 <p>ER-I-05/CM Tin Interface with Click Module</p>	 <p>ER-I-05A/EZC/ECO Tin Interface A with ezClick connection</p>	 <p>ER-I-25 Tin Interface with Curved Base for Corrugated Roof</p>	 <p>EZ-AD-C43 Adapter (Puck) for Corrugated Iron Roof</p>
 <p>ER-HB-8/150 Hanger Bolt for wood purlin</p>	 <p>ER-HB-MP/8/150EP Hanger Bolt for metal purlin</p>			

System Overview

Overview of PVezRack® SolarRoof

Tile Roof

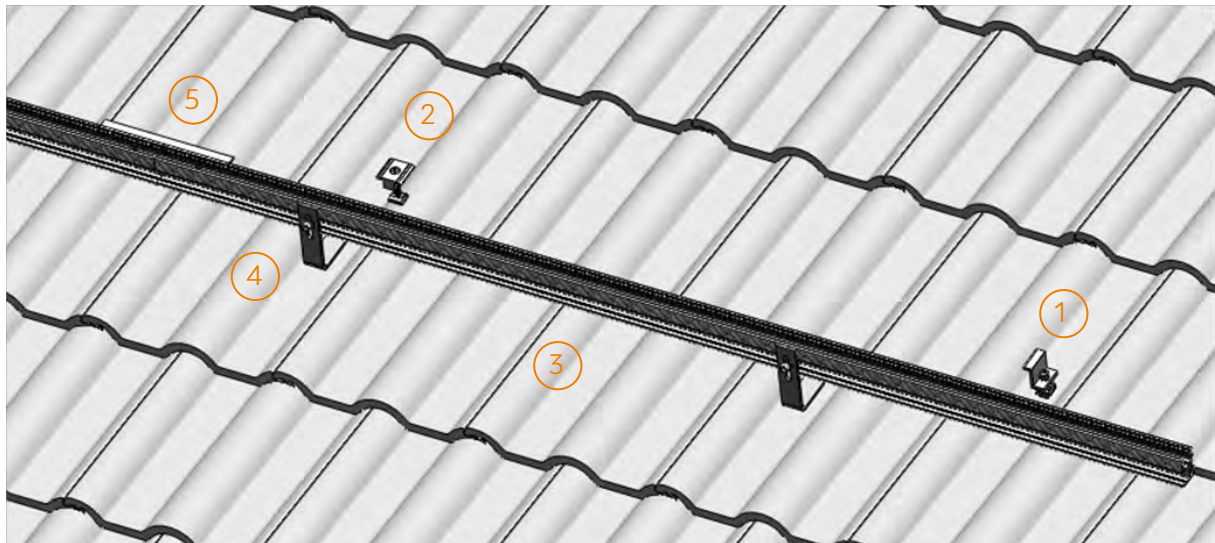

1. End Clamp 2. Inter Clamp 3. ECO Rail 4. Tile interface 5. Splice for ECO Rail

Tin Roof

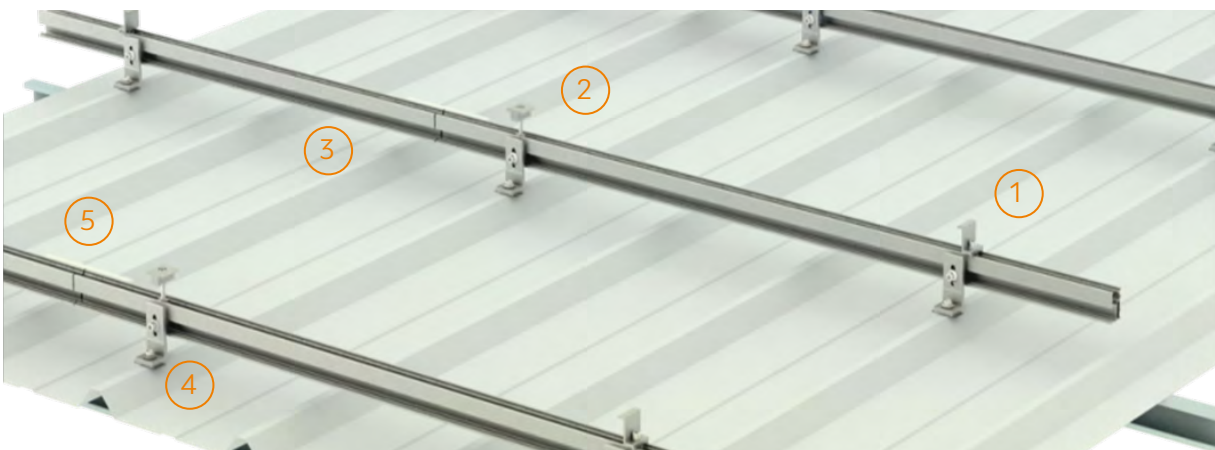

1. End Clamp 2. Inter Clamp 3. ECO Rail 4. Tin interface 5. Splice for ECO Rail

Precautions during Stainless Steel Fastener Installation

Improper operation may lead to deadlock of Nuts and Bolts. The steps below should be applied to stainless steel nut and bolt assembly to reduce this risk.

General installation instructions:

- (1) Apply force to fasteners in the direction of thread
- (2) Apply force uniformly, to maintain the required torque
- (3) Professional tools and tool belts are recommended
- (4) In some cases, fasteners could be seized over time. As an option, if want to avoid galling or seizing of thread, apply lubricant (grease or 40# engine oil) to fasteners prior to tightening.

Safe Torques

Please refer to safe torques defined in this guide as shown in the figures below. In case power tools are required, Clenergy recommends the use of low speed only. High speed and impact drivers increase the risk of bolt galling (deadlock) If deadlock occurs and you need to cut fasteners, ensure that there is no load on the fastener before you cut it. Avoid damaging the anodized or galvanized surfaces.

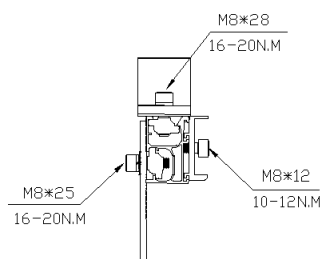

ER-I-01 and other tile interfaces

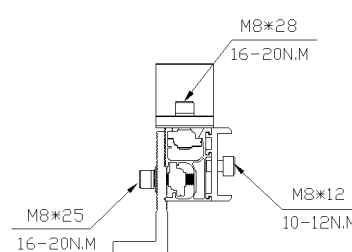

ER-I-05 and ER-I-25

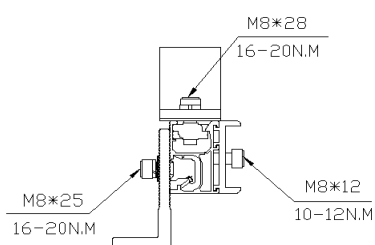

ER-I-05/CM

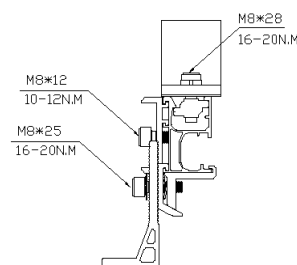

ER-I-05A/EZC/ECO

Installation Instructions

Installation Dimensions

All drawings and dimensions in this Installation Guide are a generic reference only. PVezRack® SolarRoof is to be optimized to suit specific conditions for each project and should be documented in a construction drawing.

Major components of PVezRack® SolarRoof may be provided in section sizes and lengths varying from those shown in this guide. The installation process detailed in this instruction guide remains the same regardless of changes in component size.

If you need to do any on-site modifications or alteration of the system please provide marked up drawings/sketches for Clenergy’s review, prior to modification, for comment and approval.

Installation Instruction

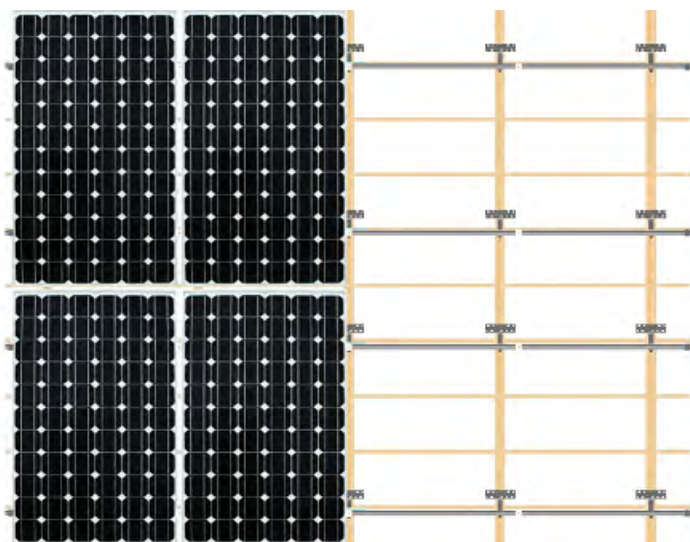

- Assess the number of modules in the vertical direction using the module height plus at least 18mm between modules (please check the installation manual of the solar module manufacturer);
- Assess the Number of modules in the horizontal direction using the module width plus 18 mm (20 mm if using Universal Clamps) between the modules.

Notes:

The standard end clamp will also add 20 mm (except for dual end clamps) on each side to the space required;

- Assess the horizontal spacing of the Roof Hooks;
- Assess the vertical spacing of the Roof Hooks = approx. 1/2 to 3/4 of module height;
- Always check the installation manual of the PV-Module you use in order to determine the allowed fixing points on the module frame.

Tile Interface Installation

Determine the positions of the Roof Hooks according to your plans. Remove the roof tiles at the marked positions or, if possible, simply push them up slightly, shown in Figures 5.3C and 5.3D.

Fix the Roof Hooks to the rafter using Clenergy provided Buildex 14 gauge Hex Head Zips screw with minimum 25 mm embedment as shown in the figure on the right following the Buildex screws installation guide below:

- Use a 3/8" Hex Socket.
- Use a mains powered or cordless screw driver with a drive speed of 3,000 RPM maximum.
- Fit the driver bit into the screw and place at the fastening position.
- Apply consistently firm pressure (end load) to the screw driver until the screw is fastened.

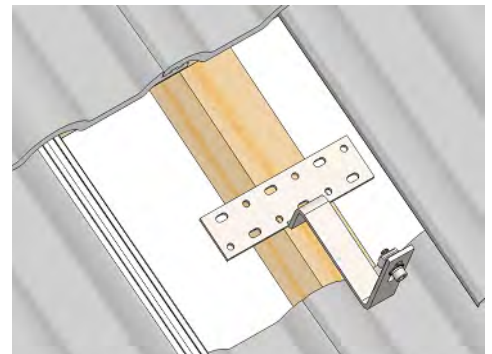
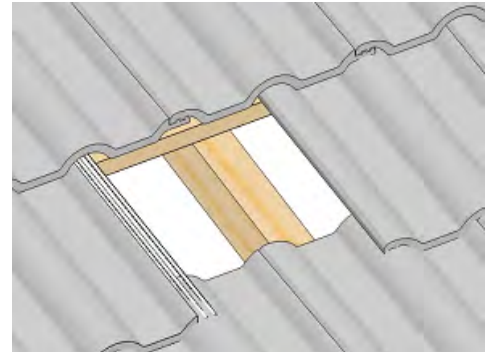

The roof hook must not press against the roof tile. If necessary, pack the roof hook with max pack height of 17 mm for Clenergy provided Buildex 50 mm long screw, with max pack height of 35 mm for Clenergy provided Buildex 65 mm long screw.

Incorrect

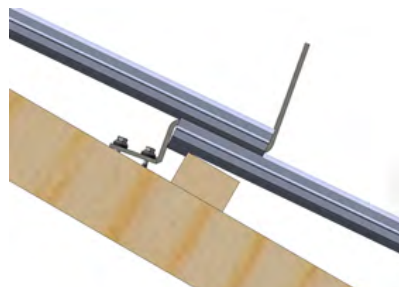

Correct

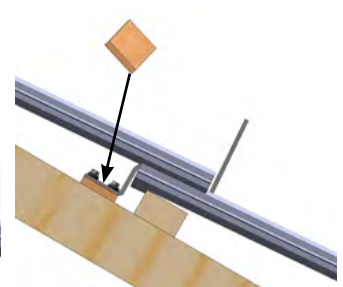

If necessary, use an angle grinder to cut a recess in the tile covering the Roof Hook at the point where the Roof Hook extends so that the tile lies flat on the surface. If grooved tiles are used, it will also be necessary to cut a recess in the lower tile.

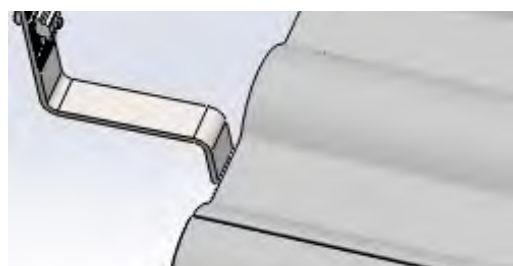
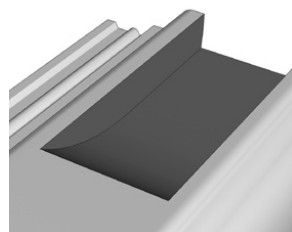

Caution! Do not use fitted roof hooks as a ladder, as this extreme point load could damage the tile below.



Variation for installation on plain tile roofs with plain tile roof cladding: A recess must be cut into the tiles around the position of the roof hook. The tile flashing should be used if necessary to prevent ingress of water.

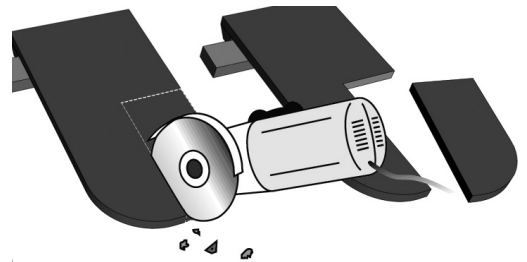

Rail Installation

To connect several rails together, slide half of the splice into the rear side of the rail. Fasten the first M8 Bolt using an Allen key, and slide the next rail into the splice. Tighten the second M8 Bolt using an Allen key. Splice provides the electrical connection between the 2 rails through the pressure bolts. This eliminates the need of using 2 earthing lugs. Recommended torque is 10 ~12 Nm.

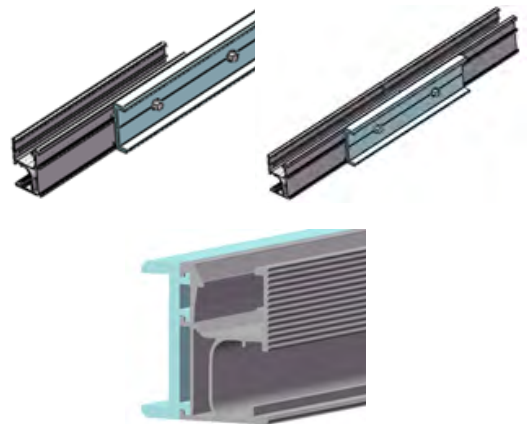

If the rails consist of different lengths, always begin with the shortest piece. Install the PV modules on the Roof Hooks and fasten loosely with M8 x 25 bolt and washers as shown in the figure on the right. Two to three screw turns are adequate for loose installation.

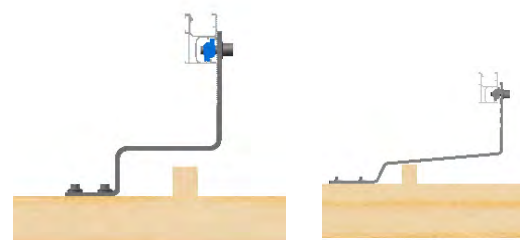

ER-I-01

ER-I-02



ER-I-01/EZC/ECO



ER-I-51

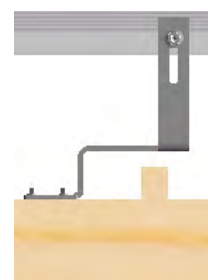

ER-I-23

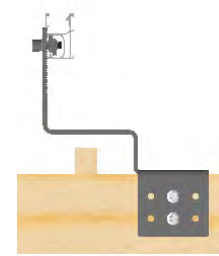

ER-I-26

Adjust the vertical and horizontal positioning using the long hole in the Roof Hook and the loosely connected Z Module in the rail, as shown in the figure on the right. The roof hook should not protrude over the rail after the adjustment.

The recommended torque is 16~20N·m.

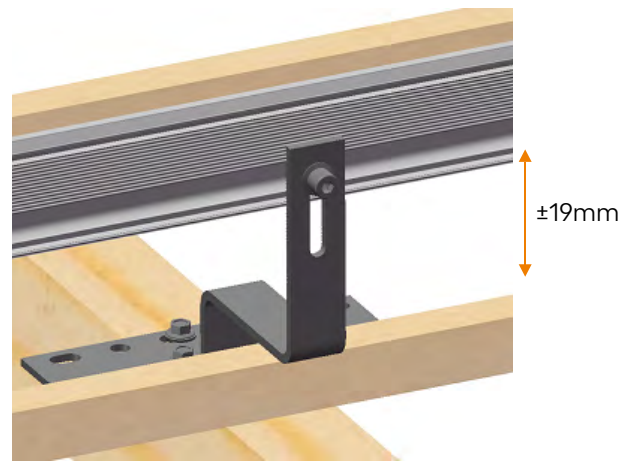

PV Module Installation

- 1) Please refer [PVezRack® Grounding System](#) for PV modules clamps and grounding lugs installations.
- 2) The installers must ensure panel clamps are installed flush mounted to the panel frame and apply correct torque value of clamp fastener as shown in section "**Safe Torques (Page 11)**".

Tin Interface Installation

For installations using ER-I-05, Tin Interface equipped with Buildex 14-11 x 70 (14 gauge, 6.3 mm, 11 TPI, 70 mm long) Hex Head Zips screw. Fix the ER-I-05 at the planned locations on metal or wood purlins as shown in the figure on the right following the Buildex screws installation guide below:

- Use a 3/8" Hex Socket.
- Use a mains powered or cordless screw driver with a drive speed of 3,000 RPM maximum.
- Fit the driver bit into the screw and place at the fastening position.
- Apply consistently firm pressure (end load) to the screw driver until the screw is fastened.
- Screws with bonded washers should be tightened only until the washer is gripped firmly enough to provide a watertight seal. The screws should be neither under tightened nor over tightened to lead to water penetration. Take particular care to ensure the screw is driven perpendicular to the interface to avoid deformation of the washer.

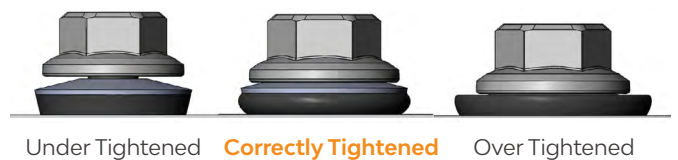
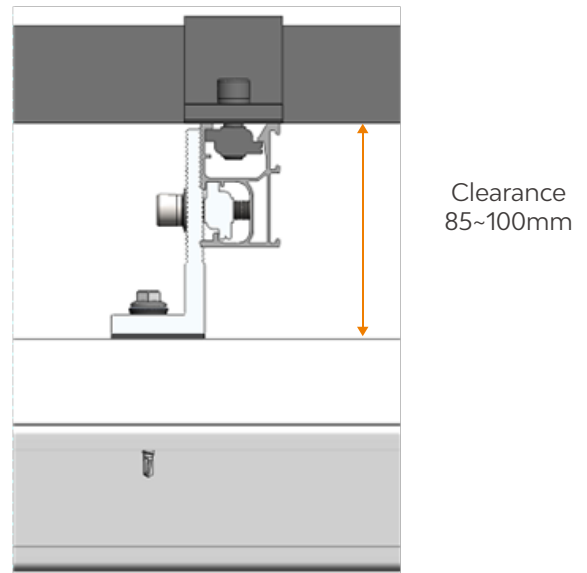

Repeat "**Rail Installation (Page 14)**" and "**PV Module Installation (Page 15)**" to install the Rails and PV Modules.

Notes:

- The purlin thickness should be no less than 0.42mm and no more than 2.4mm;
- Please refer to the recommended torques in "**Safe Torques (Page 11)**";
- Screws not exposed to frequent rain should be washed down with fresh water at least every 6 months to meet the warranty conditions of Buildex screws.

For installations using ER-I-05/CM, Tin Interface with Click Module, equipped with Buildex 14-11 x 70 (14 gauge, 6.3 mm, 11 TPI, 70 mm long) Hex Head Zips screw. . Fix the ER-I-05/CM at the planned locations on metal or wood purlins as shown in the figure on the right following the Buildex screws installation guide above. Repeat "Rail Installation (Page 14)" and "PV Module Installation (Page 15)" to install the Rails and PV Modules.

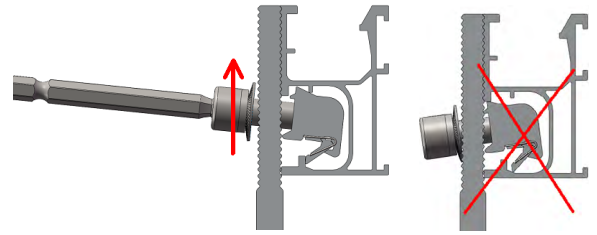

When fastening ER-I-05/CM with rail, it needs to lift up the bolt of click module to make click module well touch with upper rib of side channel of rail. So, the click module can be fixed into the rail properly as shown in the figure on the right.

Notes:

- The purlin thickness should be no less than 0.42mm and no more than 2.4mm;
- Please refer to the recommended torques in "Safe Torques (Page 11)";
- Screws not exposed to frequent rain should be washed down with fresh water at least every 6 months to meet the warranty conditions of Buildex screws.

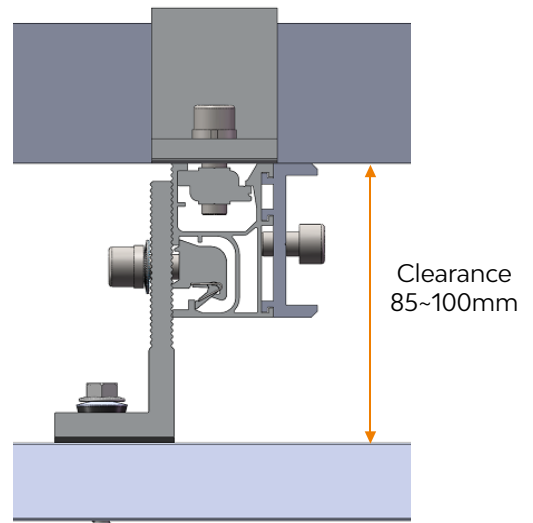

For installations using ER-I-05A/EZC/ECO, Tin Interface with ezClick connection with Buildex 14-11 x 70 (14 gauge, 6.3 mm, 11 TPI, 70 mm long) Hex Head Zips screw. Fix the ER-I-05A/EZC/ECO at the planned locations on metal or wood purlins as shown in the figure on the right following the Buildex screws installation guide above. Repeat "Rail Installation (Page 14)" and "PV Module Installation (Page 15)" to install Rails and PV Modules.

Notes:

- The purlin thickness should be no less than 0.42mm and no more than 2.4mm;
- Please refer to the recommended torques in "Safe Torques (Page 11)";
- Screws not exposed to frequent rain should be washed down with fresh water at least every 6 months to meet the warranty conditions of Buildex screws.

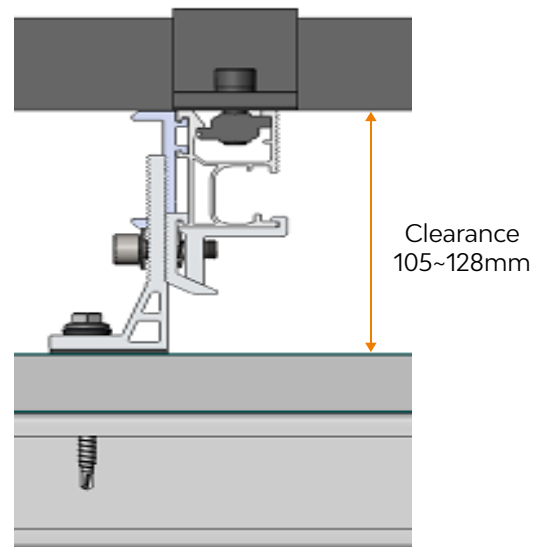

For installations using ER-I-25, Tin Interface with Curved Base for Corrugated Roof with Buildex 14-11 x 70 (14 gauge, 6.3 mm, 11 TPI, 70 mm long) Hex Head Zips screw. Fix the ER-I-25 at the planned locations on metal or wood purlins as shown in the figure on the right following the Buildex screws installation guide above. Repeat "Rail Installation (Page 14)" and "PV Module Installation (Page 15)" to install Rails and PV Modules.

Notes:

- The purlin thickness should be no less than 0.42mm and no more than 2.4mm;
- Please refer to the recommended torques in "Safe Torques (Page 11)";
- Screws not exposed to frequent rain should be washed down with fresh water at least every 6 months to meet the warranty conditions of Buildex screws.

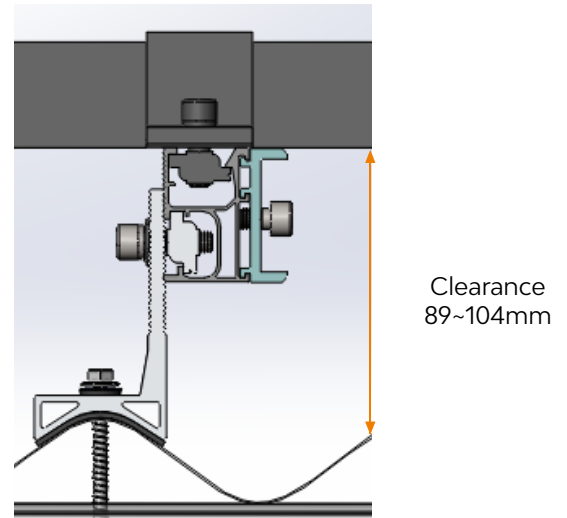

For installations using EZ-AD-C43 and ER-I-05, Adapter (Puck) for Corrugated Iron Roof and Tin Interface. Attach the EZ-AD-C43 on the planned position and then fix the ER-I-05 on metal or wood purlins as shown in the figure on the right following the Buildex screws installation guide above. Repeat "Rail Installation (Page 14)" and "PV Module Installation (Page 15)" to install Rails and PV Modules.

Notes:

- The purlin thickness should be no less than 0.42mm and no more than 2.4mm;
- Please refer to the recommended torques in "Safe Torques (Page 11)";
- Screws not exposed to frequent rain should be washed down with fresh water at least every 6 months to meet the warranty conditions of Buildex screws.

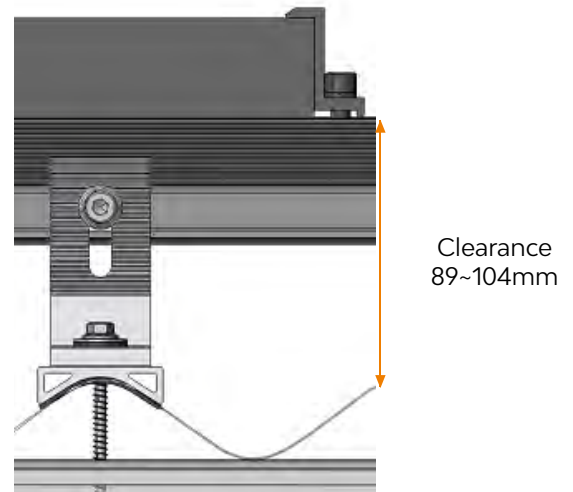

The rail is perpendicular to the Rib of metal sheet roof

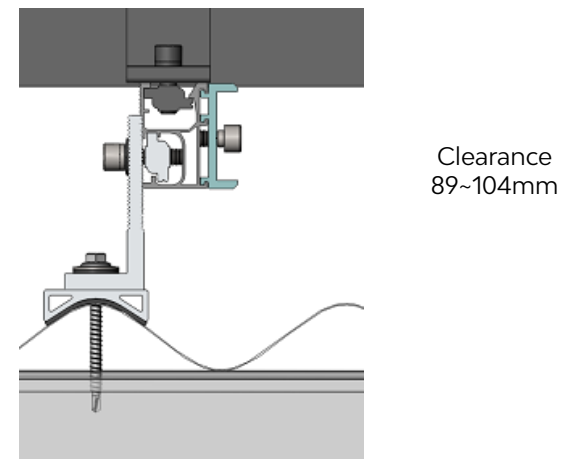

The rail is parallel to the Rib of metal sheet roof

NOTE:
WHEN USING TIN INTERFACES FOR INSTALLATION WORKS, SCREWS NOT EXPOSED TO FREQUENT RAIN SHOULD BE WASHED DOWN WITH FRESH WATER AT LEAST EVERY 6 MONTHS TO MEET THE WARRANTY CONDITIONS OF BUILDEX SCREWS.

Side Channel Cover for Cutter-Rail Installation (optional)

After cables going into the side channel of Cutter-Rail, click covers into side channel of Cutter-Rail at the required places shown in Figures at the right side.

Notes:

1. Side channel cover is made of mill finish aluminium, which is only compatible with Cutter rail;
2. The main purpose of side channel cover is to cover the cables running through side channel of Cutter rail. To achieve the cable management purpose is also to require ezclick tile or tin interfaces only as they can leave side channel full open and not cause any obstruction or damage to the cables;
3. If requires the position adjustment, it is recommended to slide it on the channel rather than uninstalation and reinstallation, which could deform it due to very thin thickness.

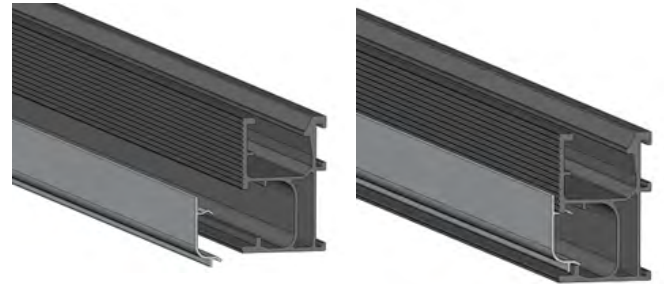

Hanger Bolt Installation

Hanger Bolt for Tile Roof Installation

Hanger bolt (ER-HB-8/150) installation on tile roof is only applicable for tile having some part of flat surface, where the rubber seal of hanger bot can mount flush on the tile not to cause waterproof problem. Please note it is installer’s responsibility to verify feasibility of tile brackets penetration and to ensure tiles are not cracked and damaged in hanger bolt installation.

1. Purlins are to be identified when opening tiles and their positions are marked out on the tiles.
2. Based on installation plan and Hanger bolt spacing info., hanger bolt locations are marked on the tiles.

Notes:

Please find tin interface spacing in the certification letter for hanger bolt spacing.

3. Drill 10 mm hole on the marked location of tile and stop when reaching the purlins.

Note: For some installations, it needs to drill through two tiles (overlap) to reach the purlin.

4. Through 10 mm hole on the tiles, pre-drill 6.5 mm hole on the wood purlin for hanger bolt. The tiles are not removed when drilling this hole. After the drilling, clean the dust around 10 mm hole.

5. Adjust the position of rubber seal on the hanger bolt (ER-HB-8/150) to ensure hanger bolt have minimum 25 mm penetration depth into the wood purlin.

Drive and press the hanger bolt firmly in an axial manner to the wood purlin till the rubber seal is firmly flush on the tile and turn the nut down till touching the rubber seal. Please apply for low rotational speed of drive, preferably less than 300 rpm to reduce threads damage. Please turn another 4 threads cycle to press the rubber seal.

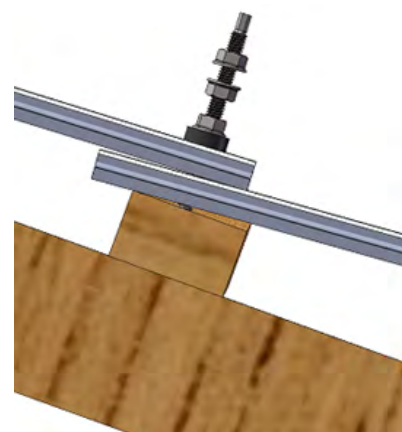
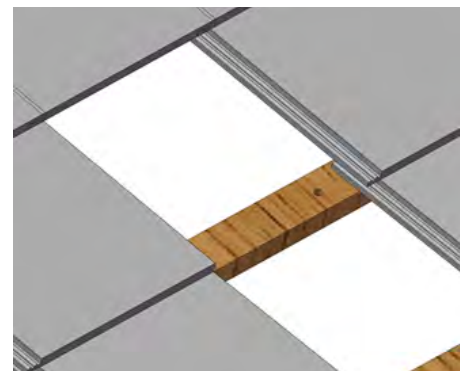
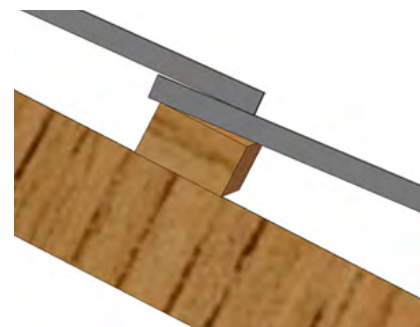
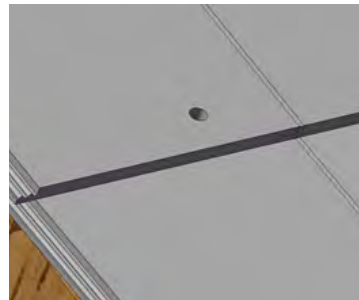

Notes:

1) Purlin thickness and tile thickness need to be verified to decide position of rubber seal for appropriate penetration depth;

2) It shall apply Sikaflex (or similar) sealant around the bolt to fill the gap between the bolt and tile before fixing hanger bolt. Please refer Sikaflex (or similar) instruction for use. It is also recommended to use Loctite Threadlocker Blue (or similar) for the nut holding the rubber seal in place to prevent hanger bolt/nut from leaking or loosening. Please refer Loctite (or similar) instruction for use.

6. Screw out the top nut of hanger bolt, connect and adjust tin foot position and tighten the top nut with the recommended torque of 16-20 N·m.

Follow sections "Rail Installation (Page 14)" and "PV Module Installation (Page 17)" to install the Rails and PV Modules.

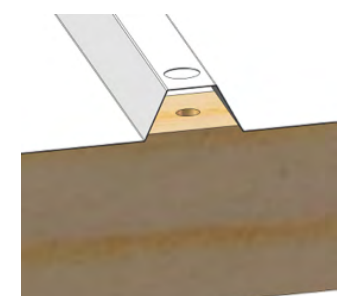
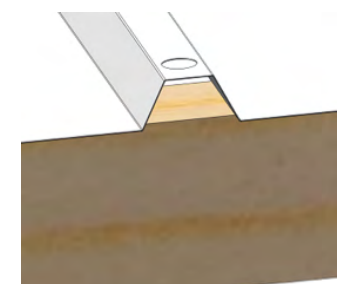
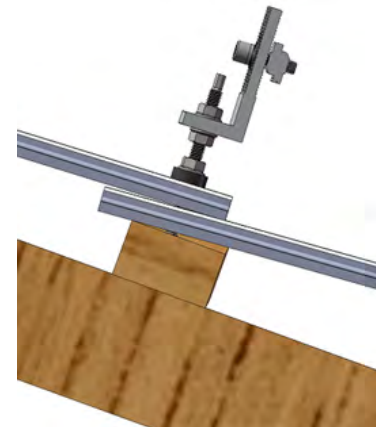

Hanger Bolt for Tin Roof Installation

Hanger Bolt for Tin Roof Installation

1. Hanger Bolt for wood purlin Installation

Hanger bolt (ER-HB-8/150) installation on tin roof is recommended for trapezoidal profile of roof or similar one having flat surface on the rib.

Drill 11 mm hole on the marked location of roof sheet according to installation plan.

Through 11 mm hole on the roof sheet, pre-drill 6.5 mm hole on the wood purlin for hanger bolt.

Adjust the position of rubber seal on the hanger bolt (ER-HB-8/150) to ensure hanger bolt have minimum 25 mm penetration depth into the wood purlin.

Drive and press the hanger bolt firmly in an axial manner to the wood purlin till the rubber seal is firmly flush on the tile and turn the nut down till touching the rubber seal. Please apply for low rotational speed of drive, preferably less than 300 rpm to reduce threads damage. Please turn another 4 threads cycle to press the rubber seal.

Notes:

1) Penetration depth into the wood purlin is used to decide position of rubber seal;

2) It shall apply Sikaflex (or similar) sealant around the bolt to fill the gap between the bolt and tin roof sheet before fixing hanger bolt. Please refer Sikaflex (or similar) instruction for use. It is also recommended to use Loctite Threadlocker Blue (or similar) for the nut holding the rubber seal in place to prevent hanger bolt/nut from leaking or loosening. Please refer Loctite (or similar) instruction for use.

3) The roof sheet should not have visible deformation after hanger bolt installation.

Screw out the top nut of hanger bolt, connect and adjust tin foot position and tighten the top nut with the recommended torque of 16-20 N·m

Follow sections "Rail Installation (Page 14)" and "PV Module Installation (Page 16)" to install the Rails and PV Modules.

2. Hanger Bolt for metal purlin Installation

Hanger bolt (ER-HB-MP/8/150EP) installation on tin roof is recommended for trapezoidal profile of roof or similar one having flat surface on the rib.

Drill 11 mm hole on the marked location of roof sheet according to installation plan.

Through 11 mm hole on the roof sheet, pre-drill 6.5 mm hole on the metal purlin for hanger bolt.

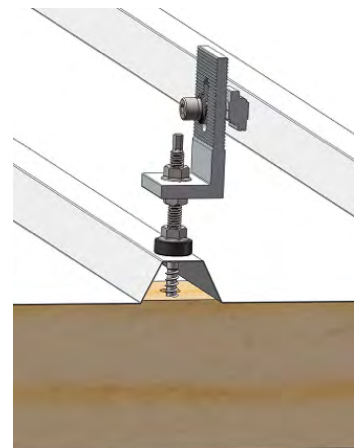
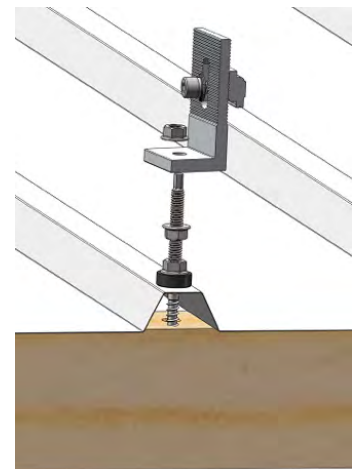
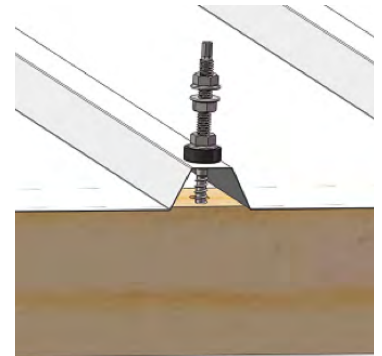

Drive and press the hanger bolt (ER-HB-MP/8/150EP) firmly in an axial manner to the metal purlin till the rubber seal is firmly flush on the tile and turn the nut down till touching the rubber seal. Please apply for low rotational speed of drive, preferably less than 300 rpm to reduce threads damage. Please turn another 4 threads cycle to press the rubber seal.

Notes:

- 1) It shall apply Sikaflex (or similar) sealant around the bolt to fill the gap between the bolt and tin roof sheet before fixing hanger bolt. Please refer Sikaflex (or similar) instruction for use. It is also recommended to use Loctite Threadlocker Blue (or similar) for the nut holding the rubber seal in place to prevent hanger bolt/nut from leaking or loosening. Please refer Loctite (or similar) instruction for use.
- 2) The roof sheet should not have visible deformation after hanger bolt installation.

Screw out the top nut of hanger bolt, connect and adjust tin foot position and tighten the top nut with the recommended torque of 16~20 N·m.

Follow sections "Rail Installation (Page 14)" and "PV Module Installation (Page 17)" to install the Rails and PV Modules.

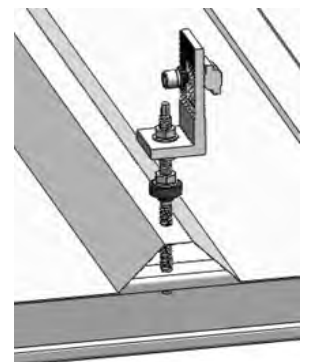
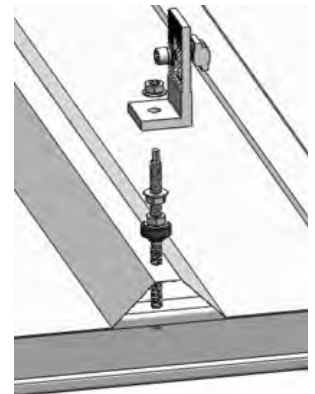
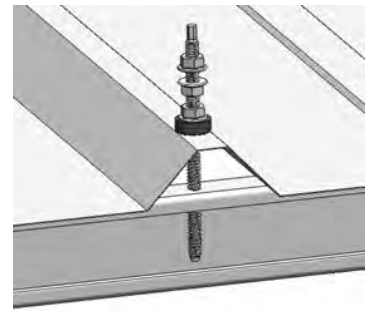

Engineering Certificate



PV Array Frame Engineering Certification

PV-ezRack SolarRoof Tin and Tile Flush Mount Penetrative Fixing System with ER-R-ECO Rail in New Zealand

For: Clenergy Australia
Suite 1, 10 Duerdin St
Clayton, VIC 3168

Job No.: 13708 - 01
Date: 24/01/2025



Gamcorp Pty Ltd
ACN: 665 643 658 | ABN: 86 665 643 658



Gamcorp
+61 3 9543 2211
www.gamcorp.com.au
info@gamcorp.com.au

Document Control Record

A person using Gamcorp document or data accepts the risk of:

- a. Using the documents or data in electronic form without requesting and checking them for accuracy against the original hard copy version
- b. Using the documents or data for any purpose not agreed to in writing by Gamcorp.

Document Control						
Report Title		PV Array Frame Engineering Certification				
Document ID		13708-01 Rev1/JD	Job No.		13708	
File Path		G:\Shared drives\13700\13700 - 13799\13708\03 CERTIFICATION				
Client		Clenergy Australia		Client Contact	Geza Anderson	
Rev	Date	Revision Details	Prepared By	Author	Verifier	Approver
0	06/10/2023	Certificate Updated (Rev.1 of 13596)	JD	JD	JG	JG
1	24/01/2025	Adding Zano Panel Clamps	HS	JD	AA	LvS
Current Revision		1				

Approval			
Author Signature		Approver Signature	
Name	Humam Sami	Name	L. Van Spaandonk
Title	Senior Structural Engineer	Title	Principal Engineer

COPYRIGHT: The concepts and information contained in this document are the property of Gamcorp Pty Ltd. Use or copying of this document in whole or in part without the written permission of Gamcorp constitutes an infringement of copyright.

LIMITATION: This report has been prepared on behalf of and for the exclusive use of Gamcorp Pty Ltd's Client, and is subject to and issued in connection with the provisions of the agreement between Gamcorp Pty Ltd and its Client. Gamcorp Pty Ltd accepts no liability or responsibility whatsoever for or in respect of any use of or reliance upon this report by any third party.

Our Ref:13708-1 Rev1/JD
24 January 2025

Clenergy Australia
Suite 1, 10 Duerdin St
Clayton, VIC 3168

PV Array Frame Engineering Certification

PV-ezRack SolarRoof Tin and Tile Flush Mount Penetrative Fixing System with ER-R-ECO Rail in New Zealand

Gamcorp Pty Ltd, being Structural Engineers within the meaning of Australian Building Regulations, have carried out a structural design check of Clenergy PV-ezRack SolarRoof Tin and Tile Flush Mount System installation with penetrative fixing within New Zealand. The design check has been based on the information and test reports provided by Clenergy Australia.

This certificate is **only valid** for Clenergy PV-ezRack SolarRoof. The roof structure or the building structure and PV panels shall be assessed separately and accordingly.

This certificate is **only valid** as a whole. Any information extracted from this certificate is not valid if standing alone.

We find the Installation of Clenergy PV-ezRack SolarRoof Flush Mount System for New Zealand use to be structurally sufficient based on the following conditions:

- Loading to:
 - AS/NZS1170.0:2002 – Structural design actions, Part 0: General principles;
 - AS/NZS1170.1:2002 – Structural design actions, Part 1: Permanent, imposed and other actions;
 - AS/NZ1170.2:2021 Wind actions;
 - AS/NZ1170.3:2003 Snow and ice actions;
 - NZS 4219:2009 Seismic performance of engineering systems in buildings.
- Corrosion calculation for **corrosion zone C1 – C5** refer to
 - ISO 9223:2012-Corrosion of metals and alloys - Corrosivity of atmospheres - Classification, determination and estimation
 - ISO 9224:2012-Corrosion of metals and alloys - Corrosivity of atmospheres - Guiding values for the corrosivity categories
 - ISO 9226:2012-Corrosion of metals and alloys - Corrosivity of atmospheres - Determination of corrosion rate of standard specimens for the evaluation of corrosivity
- Importance level **2**; Design life **25 years**
Wind average recurrence interval of **250 years**
Snow average recurrence interval of **50 years**

- Wind region **NZ1 to NZ4**
- Snow region
 - Sub-alpines (Regions N1 to N5)
 - Alpine regions are excluded for snow assessment
- Wind terrain category **2 & 3**
- Maximum building height **20m**
- The assessed base PV panel dimensions are **2000mm x 1000mm**
- PV panel to be parallel to the roof surface
- Maximum wind pressure is limited to **5kPa**
- Maximum Weight of the PV panels to be **15 kg/m²**
- Rails to be **ER-R-ECO**
- The base interface spacing is according to fixing into minimum **1.5BMT** steel or minimum **35mm embedment** into JD4 seasoned timber
- The interface spacing chosen for installation must be the **minimum value** in the attached table, which are determined by earthquake, snow and wind loads
- Each PV panel to be installed using **2 rails** minimum in all circumstances
- No PV panel to be installed within **2xs** from edges and ridge. "**s**" is the maximum gap between the underside of the panel and the roof surface when installed on the roof (**50mm ≤ s ≤ 300mm**)
- Installation of PV panels to be done in accordance with the PV panels installation manual
- The certification **excludes** assessment of roof structure and PV panels

Refer to summary table for interface spacing (Unit: mm).

There are two sets of tables. One set is for using fasteners of 14g-10 TPI screw and the other set is using fasteners of M8x150 hanger bolt.

NOTES:

- **The recommended spacing nominated in this certification is based on the capacity of the array frame and the fixing of array frames to the roof, not the roof structure and PV panels. It is the responsibility of the installer to adopt the most critical spacing.**
- **The spacing shown in the interface tables shall be adjusted based on the assessment and requirement of the roof structures.**
- **If any of the above conditions cannot be met, the structural engineer must be notified immediately.**

Construction is to be carried out strictly in accordance with the manufacturer's instructions. This work was designed by **Jiewen Deng** in accordance with the provisions of relevant Building Regulations and in accordance with sound, widely accepted engineering principles. This certificate is only valid till 24/01/2027. Gamcorp should be contacted for future validation. Contact Gamcorp for a customized system or if the site conditions are not covered by this assessment.

Yours faithfully,
Gamcorp Pty Ltd



L. Van Spaandonk

Principal Engineer

FIEAust CPEng NER 5038980

APEC Engineer IntPE(Aus) CMEngNZ 2003796

NT Registration: 244137ES

QLD Registration: 18703

VIC Registration: PE0001956

TAS Registration: CC7366

Gamcorp Pty Ltd A.C.N 665 643 658 A.B.N 86 665 643 658
www.gamcorp.com.au melbourne@gamcorp.com.au
37 Butler St, Richmond VIC 3121
Tel: 03 9543 2211

Structural Design Documentation

Flush Array Frame System Spacing Table

According to AS/NZS 1170.2-2021

with ECO Rail - Tin & Tile Roof (Pierced Fix Roof)

With Fasteners - 14g-10 TPI screws or approved equivalent

within New Zealand

Terrain Category 2 & 3

For: CLENERGY AUSTRALIA
1/10 Duerdin St
Clayton, VIC 3168

Job Number: 13708 (Eco Rail & 14g-10 TPI screws)

Revision: 1

Date: 22 January 2025



COPYRIGHT: The concepts and information contained in this document are the property of Gamcorp Pty Ltd. Use or copying of this document in whole or in part without the written permission of Gamcorp constitutes an infringement of copyright.

LIMITATION: This report has been prepared on behalf of and for the exclusive use of Gamcorp Pty Ltd's Client, and is subject to and issued in connection with the provisions of the agreement between Gamcorp Pty Ltd and its Client. Gamcorp Pty Ltd accepts no liability or responsibility whatsoever for or in respect of any use of or reliance upon this report by any third party.

Gamcorp Pty Ltd A.C.N 665 643 658 A.B.N 86 665 643 658
www.gamcorp.com.au melbourne@gamcorp.com.au
37 Butler St, Richmond VIC 3121
Tel: 03 9543 2211

Job No: 13708

Client: CLENERGY AUSTRALIA

Project: Flush Array Frame System Spacing Table

with ECO Rail - Tin & Tile Roof (Pierced Fix Roof)

With Fasteners - 14g-10 TPI screws or approved equivalent

Address: within New Zealand

Wind Terrain Category: Terrain Category 2 & 3

Australian/New Zealand Standards

AS/NZS 1170.0:2002	Structural design actions Part 0: General principles
AS/NZS 1170.1:2002	Structural design actions Part 1: Permanent, imposed and other actions
AS/NZS 1170.2:2021	Structural design actions Part 2: Wind actions
AS/NZS 1170.3:2003	Structural design actions Part 3: Snow and ice actions
AS/NZS 1664.1:1997	Aluminium structures Part 1: Limit state design
AS/NZS 4600:2018	Cold-formed steel structures
AS 4100:2020	Steel structures
NZS 4219:2009	Seismic performance of engineering systems in buildings

Designed: JD

Checked: JG

Date: Jan-25

Relationships built on trust

Client: **CLENERGY AUSTRALIA**
 Project: **Flush Array Frame System Spacing Table
 with ECO Rail - Tin & Tile Roof (Pierced Fix Roof)
 With Fasteners - 14g-10 TPI screws or approved equivalent
 within New Zealand**
 Address: **within New Zealand**

Job: **13708**
 Date: **Jan-25**
 Designed: **JD**
 Checked: **JG**

Flush Array Frame System Spacing Table for Tin Roof (mm)

Type of Rail: ER-R-ECO
 Type of Interface: ER-I-05/ER-I-25
 Solar Panel Dimension: 2mx1m
 Terrain category: 2
 Fasteners to use: With Fasteners - 14g-10 TPI screws or approved equivalent

h/d ≤ 0.5 *

Wind Region	Building Height - h (m)															
	h≤5				5<h≤10				10<h≤15				15<h≤20			
	Corner	Edge	Intermed iate	Internal	Corner	Edge	Intermed iate	Internal	Corner	Edge	Intermed iate	Internal	Corner	Edge	Intermed iate	Internal
NZ1&NZ2	665	1030	1415	1880	545	840	1145	1765	490	755	1030	1610	465	710	970	1515
NZ1&NZ2 with M_{lee} of 1.35	355	540	735	1135	--	445	600	925	--	400	540	835	--	380	510	785
NZ1&NZ2 with M_{lee} of 1.20	455	695	945	1480	375	570	770	1195	340	515	695	1075	--	485	655	1015
NZ3	490	750	1020	1595	400	610	830	1290	360	550	745	1160	340	520	705	1090
NZ4	530	815	1110	1695	435	665	905	1410	395	600	815	1265	370	565	770	1190

h/d ≥ 1.0 *

Wind Region	Building Height - h (m)															
	h≤5				5<h≤10				10<h≤15				15<h≤20			
	Corner	Edge	Intermed iate	Internal	Corner	Edge	Intermed iate	Internal	Corner	Edge	Intermed iate	Internal	Corner	Edge	Intermed iate	Internal
NZ1&NZ2	455	695	945	1475	370	565	770	1195	335	510	695	1070	--	485	655	1010
NZ1&NZ2 with M_{lee} of 1.35	--	370	495	765	--	--	410	625	--	--	370	565	--	--	350	530
NZ1&NZ2 with M_{lee} of 1.20	--	475	640	985	--	390	525	805	--	350	475	725	--	--	445	685
NZ3	--	510	685	1060	--	415	565	865	--	375	505	780	--	355	480	735
NZ4	360	550	745	1155	--	455	610	945	--	410	550	845	--	385	520	800

* For intermediate values of h/d ratios, linear interpolation shall be used. Refer Note 28 for definition h and d.

Flush Array Frame System Spacing Table for Tin Roof (mm)

Type of Rail ER-R-ECO
 Type of Interface ER-I-05/ER-I-25
 Solar Panel Dimension 2mx1m
 Terrain category **3**
 Fasteners to use With Fasteners - 14g-10 TPI screws or approved equivalent

h/d ≤ 0.5 *

Wind Region	Building Height - h (m)															
	h≤5				5<h≤10				10<h≤15				15<h≤20			
	Corner	Edge	Intermed iate	Internal	Corner	Edge	Intermed iate	Internal	Corner	Edge	Intermed iate	Internal	Corner	Edge	Intermed iate	Internal
NZ1&NZ2	810	1260	1740	1995	810	1260	1740	1995	695	1075	1480	1910	620	955	1310	1840
NZ1&NZ2 with M_{lee} of 1.35	430	660	895	1395	430	660	895	1395	370	565	770	1190	--	505	685	1060
NZ1&NZ2 with M_{lee} of 1.20	550	845	1155	1770	550	845	1155	1770	475	730	990	1550	425	650	880	1375
NZ3	590	910	1250	1795	590	910	1250	1795	510	785	1070	1680	455	700	950	1485
NZ4	640	990	1360	1820	640	990	1360	1820	555	855	1165	1725	495	760	1035	1620

h/d ≥ 1.0 *

Wind Region	Building Height - h (m)															
	h≤5				5<h≤10				10<h≤15				15<h≤20			
	Corner	Edge	Intermed iate	Internal	Corner	Edge	Intermed iate	Internal	Corner	Edge	Intermed iate	Internal	Corner	Edge	Intermed iate	Internal
NZ1&NZ2	550	845	1150	1765	550	845	1150	1765	475	725	985	1540	420	645	875	1365
NZ1&NZ2 with M_{lee} of 1.35	--	445	605	930	--	445	605	930	--	385	520	800	--	345	465	715
NZ1&NZ2 with M_{lee} of 1.20	375	575	775	1205	375	575	775	1205	--	495	670	1030	--	440	595	920
NZ3	405	615	835	1300	405	615	835	1300	350	530	720	1115	--	475	640	990
NZ4	435	670	910	1420	435	670	910	1420	380	580	785	1215	340	515	695	1075

* For intermediate values of h/d ratios, linear interpolation shall be used. Refer Note 28 for defination h and d.

Client: **CLENERGY AUSTRALIA**
 Project: **Flush Array Frame System Spacing Table
 with ECO Rail - Tin & Tile Roof (Pierced Fix Roof)
 With Fasteners - 14g-10 TPI screws or approved equivalent
 within New Zealand**

Job: **13708**
 Date: **Jan-25**
 Designed: **JD**
 Checked: **JG**

Flush Array Frame System Spacing Table for Tile Roof (mm)

Type of Rail: ER-R-ECO
 Type of Interface: ER-I-01 (see Note 23 for other Tile interfaces)
 Solar Panel Dimension: 2mx1m
 Terrain category: **2**
 Fasteners to use: With Fasteners - 14g-10 TPI screws or approved equivalent

h/d ≤ 0.5 *

Wind Region	Building Height - h (m)															
	h≤5				5<h≤10				10<h≤15				15<h≤20			
	Corner	Edge	Intermed iate	Internal	Corner	Edge	Intermed iate	Internal	Corner	Edge	Intermed iate	Internal	Corner	Edge	Intermed iate	Internal
NZ1&NZ2	405	635	885	1455	330	515	710	1150	--	460	635	1015	--	435	600	955
NZ1&NZ2 with M _{lee} of 1.35	--	325	450	710	--	--	365	570	--	--	325	515	--	--	--	480
NZ1&NZ2 with M _{lee} of 1.20	--	425	585	930	--	345	475	745	--	--	425	670	--	--	400	630
NZ3	--	440	605	965	--	360	490	775	--	--	440	695	--	--	415	650
NZ4	--	460	635	1015	--	375	515	815	--	340	465	730	--	--	435	685

h/d ≥ 1.0 *

Wind Region	Building Height - h (m)															
	h≤5				5<h≤10				10<h≤15				15<h≤20			
	Corner	Edge	Intermed iate	Internal	Corner	Edge	Intermed iate	Internal	Corner	Edge	Intermed iate	Internal	Corner	Edge	Intermed iate	Internal
NZ1&NZ2	--	425	580	925	--	345	470	745	--	--	425	665	--	--	400	625
NZ1&NZ2 with M _{lee} of 1.35	--	--	--	470	--	--	--	380	--	--	--	345	--	--	--	--
NZ1&NZ2 with M _{lee} of 1.20	--	--	390	610	--	--	--	495	--	--	--	445	--	--	--	420
NZ3	--	--	405	630	--	--	325	515	--	--	--	460	--	--	--	435
NZ4	--	--	425	665	--	--	345	540	--	--	--	480	--	--	--	455

* For intermediate values of h/d ratios, linear interpolation shall be used. Refer Note 28 for definition h and d.

Client: **CLENERGY AUSTRALIA**
 Project: **Flush Array Frame System Spacing Table
 with ECO Rail - Tin & Tile Roof (Pierced Fix Roof)
 With Fasteners - 14g-10 TPI screws or approved equivalent**

Job: **13708**
 Date: **Jan-25**
 Designed: **JD**

Flush Array Frame System Spacing Table for Tile Roof (mm)

Type of Rail: ER-R-ECO
 Type of Interface: ER-I-01 (see Note 23 for other Tile interfaces)
 Solar Panel Dimension: 2mx1m
 Terrain category: **3**
 Fasteners to use: With Fasteners - 14g-10 TPI screws or approved equivalent

h/d ≤ 0.5 *

Wind Region	Building Height - h (m)															
	h≤5				5<h≤10				10<h≤15				15<h≤20			
	Corner	Edge	Intermed iate	Internal	Corner	Edge	Intermed iate	Internal	Corner	Edge	Intermed iate	Internal	Corner	Edge	Intermed iate	Internal
NZ1&NZ2	495	785	1100	1850	495	785	1100	1850	425	670	935	1545	380	590	820	1335
NZ1&NZ2 with M _{lee} of 1.35	--	400	550	875	--	400	550	875	--	345	470	740	--	--	420	655
NZ1&NZ2 with M _{lee} of 1.20	335	520	720	1165	335	520	720	1165	--	445	610	975	--	395	545	860
NZ3	345	540	745	1210	345	540	745	1210	--	465	640	1025	--	410	565	900
NZ4	365	565	785	1275	365	565	785	1275	--	485	670	1075	--	430	595	945

h/d ≥ 1.0 *

Wind Region	Building Height - h (m)															
	h≤5				5<h≤10				10<h≤15				15<h≤20			
	Corner	Edge	Intermed iate	Internal	Corner	Edge	Intermed iate	Internal	Corner	Edge	Intermed iate	Internal	Corner	Edge	Intermed iate	Internal
NZ1&NZ2	335	515	715	1155	335	515	715	1155	--	445	610	975	--	395	540	855
NZ1&NZ2 with M _{lee} of 1.35	--	--	370	575	--	--	370	575	--	--	--	490	--	--	--	435
NZ1&NZ2 with M _{lee} of 1.20	--	350	480	755	--	350	480	755	--	--	410	640	--	--	365	565
NZ3	--	360	495	780	--	360	495	780	--	--	425	665	--	--	380	590
NZ4	--	380	520	820	--	380	520	820	--	325	445	700	--	--	395	620

* For intermediate values of h/d ratios, linear interpolation shall be used. Refer Note 28 for definition h and d.

Client: **CLENERGY AUSTRALIA**
 Project: **Flush Array Frame System Spacing Table with ECO Rail - Tin & Tile Roof (Pierced Fix Roof) With Fasteners - 14g-10 TPI screws or approved equivalent within New Zealand**
 Address: **within New Zealand**

Job: **13708**
 Date: **Jan-25**
 Designed: **JD**
 Checked: **JG**

General Notes

Note 1 Following components are satisfied to use according to AS/NZS 1170.2:2021

Components	Part Number	Description
ECO Rail	ER-R-ECO, ER-R-ECO/BA	As per drawing or test report provided by client
ECO Rail Splice	ER-SP-ECO, ER-SP-ECO/BA	
Standard Inter Clamp	ER-IC-ST, ER-IC-ST/BA	
Standard End Clamp	ER-EC-ST, ER-EC-ST/BA	
Zano Inter Clamp	ER-IC-28/42/L50/G/BA	
Zano End Clamp	ER-EC-28/42/L50/BA	
Universal Clamp	C-U/30/46, C-U/30/46/BA	
Universal Clamp with Grounding Clip	C-U/30/46-G, C-U/30/46-G/BA	
Tin Interface	ER-I-05, ER-I-05/BA, ER-I-05/CM, ER-I-25, ER-I-25/BA	
Tin Interface A with ezClick	ER-I-05A/EZC/ECO	
Corrugated Roof adapter	EZ-AD-C43, EZ-AD-C43/BA	
Tile interface	ER-I-01, ER-I-02, ER-I-04, ER-I-23, ER-I-26, ER-I-51	

Note 2 Tin roof interface spacing calculated based on 1.5mm steel purlin G450 or 35mm screw embedment into F7 (Pine) timber (JD4 seasoned timber).
 Tile roof interface spacing calculated based on 25mm screw embedment (2 screws) into F7 (Pine) timber (JD4 seasoned timber).

Recommended screws

Metal Purlins/Battens	Fasteners to use
0.42mm to 0.75mm (G550)	14g-10 TPI Teks screws or approved equivalent
1.2mm to 2.4mm (G450)	14g-10 TPI Teks screws or approved equivalent
Timber Purlins/Battens/Rafters	Fasteners to use
Softwood F7 (Pine) (JD4 seasoned timber)	14g-10 TPI T17 screws or approved equivalent
Hardwood F17 (JD3 seasoned timber)	14g-10 TPI T17 screws or approved equivalent

Note 3 Maximum uplift wind pressure is limited to 5kPa.

Note 4 Deflection is limited to Minimum of L/120 and 15mm.

Note 5 Panels to be installed parallel to the roof surface.

Note 6 "--" states NOT SUITABLE FOR INSTALLATION.

Note 7 Terrain category definition according to section 4.2.1 of AS/NZS 1170.2:2021 as follows:

Terrain Category 2 (TC2) - Open terrain, including grassland, with well-scattered obstructions having heights generally from 1.5 m to 5 m, with no more than two obstructions per hectare (e.g. farmland and cleared subdivisions with isolated trees and uncut grass).
 Terrain Category 3 (TC3) - Terrain with numerous closely spaced obstructions having heights generally from 3 m to 10 m. The minimum density of obstructions shall be at least the equivalent of 10 house-size obstructions per hectare (e.g. suburban housing, light industrial estates or dense forests).

Note 8 Wind regions are shown in Figure 3.1(B) of AS/NZS 1170.2:2021.

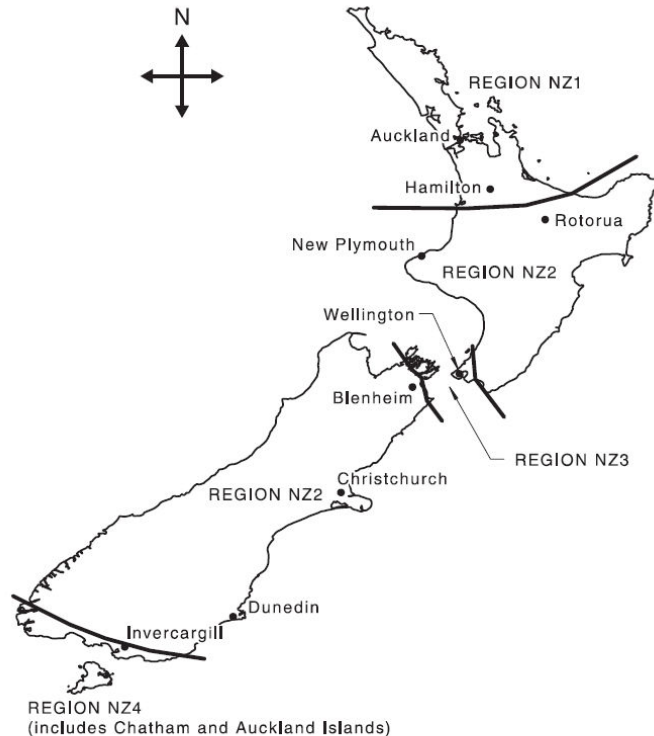

Figure 3.1(B) — Wind regions — New Zealand

Note 9 Base interface spacing to be multiplied by all applicable reduction/increase factors. Factored spacing less than one third of the panel width are not satisfied. (NOT SUITABLE FOR INSTALLATION)

Relationships built on trust

Client: **CLENERGY AUSTRALIA**
 Project: **Flush Array Frame System Spacing Table with ECO Rail - Tin & Tile Roof (Pierced Fix Roof) With Fasteners - 14g-10 TPI screws or approved equivalent within New Zealand**
 Address: **within New Zealand**

Job: **13708**
 Date: **Jan-25**
 Designed: **JD**
 Checked: **JG**

- Note 10 Wind direction multiplier (Md), Shielding multiplier (Ms) and Hill shape multiplier (Mh) are taken as 1.0.
- Note 11 Refer section 4.4 of AS/NZS 1170.2:2021 for Lee multiplier (Mlee) and topographic multiplier (Mt).
- Note 12 Lee multiplier (Mlee) is taken as 1.0 except for WR NZ1&NZ2 with Mlee which is taken as 1.35 and 1.2 separately. Refer section 4.4.1 of AS/NZS 1170.2:2021 for topographic multiplier (Mt). See Note 25 for Lee zones map.
- Note 13 The assessment includes the effect of earthquake loads. See note 27 for the fixing spacing determined by earthquake loads.
- Note 14 Alpine regions are excluded for snow assessment. See note 26 for the fixing spacing determined by snow loads.
- Note 15 Refer section 2.3 and Figure 2.2 of AS/NZS 1170.3:2003 for sub-alpine regions. Probability factor (kp) and Exposure reduction coefficient (Ce) are taken as 1.0 and Shape coefficient (μi) is taken as 0.7. See Note 26 for sub-alpine regions map.
- Note 16 Maximum panel weight is limited to 15kg/m².
- Note 17 Maximum panel width is limited to 1200mm.
- Note 18 Maximum rail and panel width overhang is limited to the 40% of the allowable interface spacing.
- Note 19 PV panels clamping zone to be according to the manufacturer's specifications.
- Note 20 This certificate is applicable for the corrosion zones C1, C2, C3, C4 and C5. Correspondent roof interface must be used for each zone. Refer SNZ TS 3404:2018 for corrosion zones definitions.
- Note 21 This assessment is based on the capacity of the fixings of array frame to the structure and the array frame itself but not PV panel nor roof structures. Other building structures are deemed to be satisfactory. It is the responsibility of the installer to adopt the most critical spacing.
- Note 22 Following reduction/increase factors to be applied to the base spacing for different type of tophat, purlin or batten or if timber screw embedment is reduced by using EZ-AD-C43 adaptor or fixing to smaller timber depth. **In any case, it is not applicable for installation if the actual fixing spacing after applying spacing ratio is less than 300mm.**

Purlin/Batten Material	Fixing Type		Purlin thickness (mm)	Min. Embedment (mm)	Spacing Reduction / Increase				
	Interface	No. of screws			WR NZ1&NZ2	WR NZ1&NZ2 with M _{lee} = 1.35	WR NZ1&NZ2 with M _{lee} = 1.20	WR NZ3	WR NZ4
Timber F7 (Pine)	Tin	1	-	25	0%	0%	0%	0%	0%
Timber F7 (Pine)	Tin	1	-	30	0%	+15%	0%	0%	0%
Timber F7 (Pine)	Tin	1	-	35	0%	+15%	0%	0%	0%
Timber F17 (HW)	Tin	1	-	25	0%	+15%	0%	0%	0%
Timber F17 (HW)	Tin	1	-	30	0%	+15%	0%	0%	0%
Timber F17 (HW)	Tin	1	-	35	0%	+15%	0%	0%	0%
Metal (G550)	Tin	1	0.42	-	-75%	-75%	-75%	-75%	-75%
Metal (G550)	Tin	1	0.48	-	-71%	-71%	-71%	-71%	-71%
Metal (G550)	Tin	1	0.55	-	-67%	-67%	-67%	-67%	-67%
Metal (G550)	Tin	1	0.75	-	-55%	-55%	-55%	-55%	-55%
Metal (G450)	Tin	1	1.2	-	-20%	-20%	-20%	-20%	-20%
Metal (G450)	Tin	1	1.5	-	0%	0%	0%	0%	0%
Metal (G450)	Tin	1	1.9	-	0%	+15%	0%	0%	0%
Metal (G450)	Tin	1	2.4	-	0%	+15%	0%	0%	0%

Note 23 Tile roof interface spacing to be reduced as follows:

Interface	Spacing Reduction
ER-I-01	0%
ER-I-02	-52%
ER-I-04	-44%
ER-I-23	0%
ER-I-26	0%
ER-I-51	-74%

Note 24 Following reduction/increase factors to be applied to the base spacing for different panel length.

In any case, the actual fixing spacing after applying spacing ratio is limited to maximum 2000mm

Panel Length (mm)	No. of Rails	Spacing Reduction / Increase				
		WR NZ1&NZ2	WR NZ1&NZ2 with M _{lee} = 1.35	WR NZ1&NZ2 with M _{lee} = 1.20	WR NZ3	WR NZ4
1700	2	+4%	+17%	+4%	+4%	+4%
	3	+15%	+37%	+15%	+15%	+15%
	4	+24%	+47%	+24%	+24%	+24%
1800	2	+3%	+11%	+3%	+3%	+3%
	3	+14%	+35%	+14%	+14%	+14%
	4	+22%	+45%	+22%	+22%	+22%
1900	2	+1%	+4%	+1%	+1%	+1%
	3	+12%	+33%	+12%	+12%	+12%
	4	+20%	+43%	+20%	+20%	+20%
2000	2	0%	0%	0%	0%	0%
	3	+11%	+32%	+11%	+11%	+11%
	4	+19%	+41%	+19%	+19%	+19%
2100	2	-5%	-5%	-5%	-5%	-5%
	3	+9%	+30%	+9%	+9%	+9%
	4	+18%	+39%	+18%	+18%	+18%
2200	2	-10%	-10%	-10%	-10%	-10%
	3	+8%	+28%	+8%	+8%	+8%
	4	+16%	+38%	+16%	+16%	+16%
2300	2	-14%	-14%	-14%	-14%	-14%
	3	+7%	+26%	+7%	+7%	+7%
	4	+15%	+36%	+15%	+15%	+15%
2400	2	-18%	-18%	-18%	-18%	-18%
	3	+6%	+24%	+6%	+6%	+6%
	4	+14%	+35%	+14%	+14%	+14%

Relationships built on trust

Client: **CLENERGY AUSTRALIA**
 Project: **Flush Array Frame System Spacing Table with ECO Rail - Tin & Tile Roof (Pierced Fix Roof) With Fasteners - 14g-10 TPI screws or approved equivalent within New Zealand**
 Address: **within New Zealand**

Job: **13708**
 Date: **Jan-25**
 Designed: **JD**
 Checked: **JG**

Note 25 Interface spacing to be reduced as follows for sites in wind regions NZ1 & NZ2 with Mlee over 500m above sea level:

Site Elevation, E (m)	Spacing Reduction
E < 500	0%
500 ≤ E < 700	-20%
700 ≤ E < 900	-24%
900 ≤ E < 1200	-31%
E ≥ 1200	N/A

North Island	
1	Kaimai
2	Taranaki
3	Ruapehu
4	Tararua
5	Tararua and Orongorongo
6	Coastal Wairarapa
South Island	
7	West Coast North
8	West Coast Alps
9	Awatere
10	Inland Kaikoura
11	Southern Alps
12	Hunter
13	Hakataramea
14	St Mary's
15	Pisa
16	Dunstan
17	Rock and Pillar

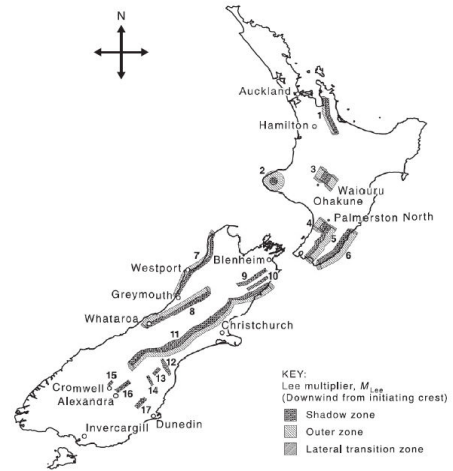

NOTE 1 Some outer and lateral transition zones are not shown.
 NOTE 2 For numbers shown, see the first column of Table 4.4.

Figure 4.6 — Locations of New Zealand lee zones

Note 26 Maximum Tin & Tile roof interface spacing in sub-alpine regions to be limited to follows for all roof zones (Tile roof interface capacity in compression must be checked separately before using these limitations).

Site Elevation, E (m)	No. of Rails	Maximum Interface Spacing (mm)			
		Snow Region N1	Snow Region N2&N3	Snow Region N4	Snow Region N5
E ≤ 100	2	N/A	N/A	N/A	1775
	3				1970
	4				2120
100 < E ≤ 200	2	N/A	N/A	N/A	1775
	3				1970
	4				2120
200 < E ≤ 300	2	N/A	N/A	N/A	1775
	3				1970
	4				2120
300 < E ≤ 400	2	N/A	N/A	N/A	1775
	3				1970
	4				2120
400 < E ≤ 500	2	N/A	N/A	N/A	1775
	3				1970
	4				2120
500 < E ≤ 700	2	N/A	N/A	N/A	1775
	3				1970
	4				2120
700 < E ≤ 900	2	N/A	N/A	N/A	1775
	3				1970
	4				2120
900 < E ≤ 1200	2	N/A	N/A	N/A	1775
	3				1970
	4				2120

2.3 NEW ZEALAND

Alpine and sub-alpine regions are defined as follows:

(a) N1 (southern portion of North Island of New Zealand, see Figure 2.2):

- (i) Sub-alpine between 400 m and 1200 m.
- (ii) Alpine ≥1200 m.

(b) N2 (South Island of New Zealand):

- (i) Sub-alpine between 200 m and 900 m.
- (ii) Alpine ≥900 m.

(c) N3 (South Island of New Zealand):

- (i) Sub-alpine between 150 m and 900 m.
- (ii) Alpine ≥900 m.

(d) N4 and N5 (South Island of New Zealand):

- (i) Sub-alpine <900 m.
- (ii) Alpine ≥900 m.

NOTE: This map is approximate only and altitude above mean sea level shall be used to determine snow region. For sub-alpine regions in the South Island (N2, N3, N4 and N5) the regions coincide with the 1988 county boundaries. Where an alpine region exists between sub-alpine regions, the alpine region separates the 2 sub-alpine regions (which extend downwards from 1200 m altitude).

FIGURE 2.2 NEW ZEALAND—APPROXIMATE LOCATIONS OF ALPINE AND SUB-ALPINE REGIONS

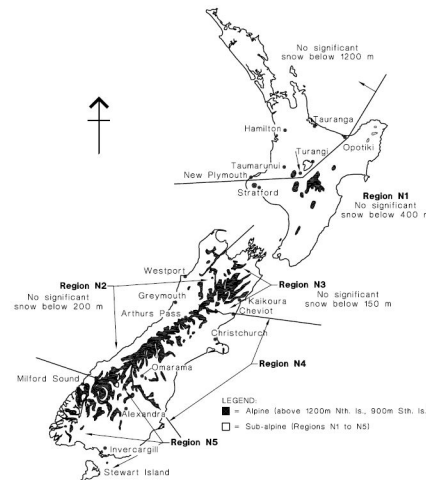

Relationships built on trust

Client: **CLEENERGY AUSTRALIA**
 Project: **Flush Array Frame System Spacing Table with ECO Rail - Tin & Tile Roof (Pierced Fix Roof) With Fasteners - 14g-10 TPI screws or approved equivalent**
 Address: **within New Zealand**

Job: **13708**
 Date: **Jan-25**
 Designed: **JD**
 Checked: **JG**

Note 27 Refer section 3.4.1 and Figure 2 of NZS 4219:2009 for zone factor (Z). Performance factor (Cp) is taken as 0.85 and Component risk factor (Rc) coefficient (Ce) is taken as 1.0 and High coefficient (Ch) is taken as 3. Maximum Tin & Tile roof interface spacing in Earthquake zone to be limited to follows for all roof zones.

Earthquake Factor, Z	No. of Rails	Maximum Interface Spacing (mm)				
		Max Panel Length 2000mm	Max Panel Length 2100mm	Max Panel Length 2200mm	Max Panel Length 2300mm	Max Panel Length 2400mm
Z ≤ 0.13	2	2000	2000	2000	2000	2000
	3	2000	2000	2000	2000	2000
0.13 < Z ≤ 0.15	2	2000	2000	2000	2000	1980
	3	2000	2000	2000	2000	2000
0.15 < Z ≤ 0.18	2	1980	1960	1935	1915	1895
	3	2000	2000	2000	2000	2000
0.18 < Z ≤ 0.20	2	1930	1905	1885	1865	1845
	3	2000	2000	2000	2000	2000
0.20 < Z ≤ 0.23	2	1865	1845	1820	1800	1775
	3	2000	2000	2000	1995	1970
0.23 < Z ≤ 0.26	2	1805	1780	1755	1730	1705
	3	2000	1975	1955	1930	1910
0.26 < Z ≤ 0.30	2	1725	1700	1675	1650	1625
	3	1930	1905	1885	1865	1845
0.30 < Z ≤ 0.35	2	1640	1615	1590	1565	1545
	3	1860	1835	1815	1795	1770
0.35 < Z ≤ 0.40	2	1570	1545	1520	1500	1475
	3	1795	1770	1740	1715	1690
0.40 < Z ≤ 0.45	2	1510	1485	1460	1440	1385
	3	1725	1700	1675	1650	1625
0.45 < Z ≤ 0.50	2	1455	1425	1360	1300	1245
	3	1670	1640	1615	1590	1570
0.50 < Z ≤ 0.55	2	1360	1295	1235	1180	1130
	3	1615	1590	1565	1540	1520
0.55 < Z ≤ 0.60	2	1245	1185	1130	1080	1035
	3	1570	1545	1520	1500	1475

Note:
 The seismic assessment is based on the rail capacity and shear capacity of fixings.

Table 3 – Zone factors for New Zealand locations (north to south)

#	Location	Z
1	Kaitiaki	0.13
2	Paihia/Russell	0.13
3	Kaikōhe	0.13
4	Whangarei	0.13
5	Dargaville	0.13
6	Warkworth	0.13
7	Auckland	0.13
8	Manakau City	0.13
9	Waikuku	0.13
10	Pukekohe	0.13
11	Thames	0.16
12	Paeroa	0.18
13	Waihi	0.18
14	Huntly	0.15
15	Ngaruawahia	0.15
16	Morrinsville	0.18
17	Te Aroha	0.18
18	Tauranga	0.20
19	Mount Maunganui	0.20
20	Hamilton	0.16
21	Cambridge	0.18
22	Te Awamutu	0.17
23	Matamata	0.19
24	Te Puke	0.22
25	Putaruru	0.21
26	Tokoroa	0.21
27	Otorohanga	0.17
28	Te Kuiti	0.18
29	Mangakino	0.21
30	Rotorua	0.24
31	Kawerau	0.29
32	Whakatane	0.30
33	Opoitiki	0.30
34	Ruatoria	0.33
35	Murupara	0.30

Table 3 – Zone factors for New Zealand locations (north to south) (continued)

#	Location	Z
36	Taupo	0.28
37	Taumarunui	0.21
38	Turangi	0.27
39	Gisborne	0.36
40	Wairoa	0.37
41	Wairata	0.18
42	New Plymouth	0.18
43	Inglewood	0.18
44	Stratford	0.18
45	Opunake	0.18
46	Hawera	0.18
47	Patea	0.19
48	Raetihi	0.26
49	Ohakune	0.27
50	Waikou	0.29
51	Napier	0.38
52	Hastings	0.39
53	Wanganui	0.25
54	Waipawa	0.41
55	Waipukurau	0.41
56	Taihape	0.33
57	Marton	0.30
58	Bulls	0.31
59	Faliding	0.37
60	Palmerston North	0.38
61	Dannevirke	0.42
62	Woodville	0.41
63	Pahiatua	0.42
64	Foxton/Foxton Beach	0.36
65	Levin	0.40
66	Otaki	0.40
67	Waikanae	0.40
68	Paraparaumu	0.40
69	Masterton	0.42

#	Location	Z
70	Porirua	0.40
71	Wellington CBD (north of Basin Reserve)	0.40
72	Wellington	0.40
73	Hutt Valley – south of Taia Gorge	0.40
74	Upper Hutt	0.42
75	Eastbourne – Point Howard	0.40
76	Wainuiomata	0.40
77	Takaka	0.23
78	Motueka	0.26
79	Nelson	0.27
80	Picton	0.30
81	Blenheim	0.33
82	St Arnaud	0.36
83	Westport	0.30
84	Reefton	0.37
85	Murchison	0.34
86	Springs Junction	0.45
87	Hammer Springs	0.55
88	Seddon	0.40
89	Ward	0.40
90	Cheviot	0.40
91	Greymouth	0.37
92	Kaikoura	0.42
93	Haritahi	0.46
94	Hokitika	0.45
95	Fox Glacier	0.44
96	Franz Josef	0.44
97	Otira	0.60
98	Arthurs Pass	0.60
99	Rangiora	0.33
100	Darfield	0.30
101	Akaroa	0.16
102	Christchurch	0.22
103	Geraldine	0.19
104	Ashburton	0.20
105	Fairlie	0.24
106	Temuka	0.17
107	Timaru	0.15
108	Mt Cook	0.38
109	Twizel	0.27
110	Waimate	0.14
111	Cromwell	0.24
112	Wanaka	0.30
113	Arrowtown	0.30
114	Alexandra	0.21
115	Queenstown	0.32
116	Milford Sound	0.54
117	Palmerston	0.13
118	Oamaru	0.13
119	Dunedin	0.13
120	Mosgiel	0.13
121	Riverton	0.20
122	Te Anau	0.36
123	Gore	0.18
124	Winton	0.20
125	Balclutha	0.13
126	Mataura	0.17
127	Bluff	0.15
128	Invercargill	0.17
129	Oban	0.14

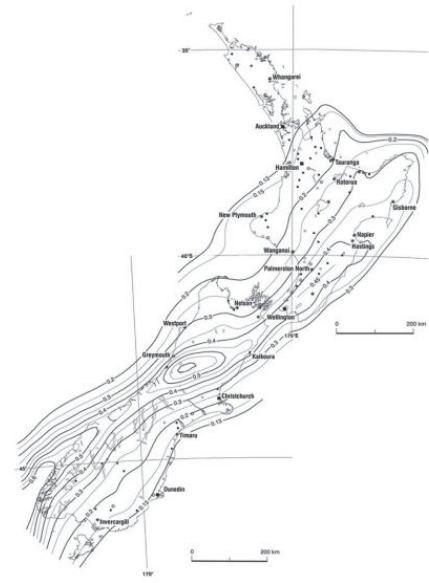

Figure 2 – Zone factor, Z

Client: **CLENERGY AUSTRALIA**
 Project: **Flush Array Frame System Spacing Table with ECO Rail - Tin & Tile Roof (Pierced Fix Roof) With Fasteners - 14g-10 TPI screws or approved equivalent**
 Address: **within New Zealand**

Job: **13708**
 Date: **Jan-25**
 Designed: **JD**
 Checked: **JG**

Note 28 Building height is average roof height of structure above ground. Refer Figure 1 for definition of h, d and b.

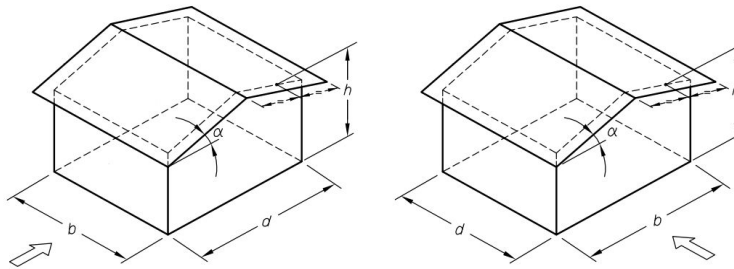
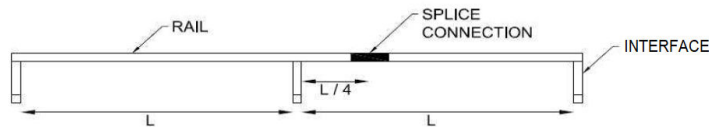

Figure 1 – h, d and b definition

Note 29 Rail splice connection must be placed at a quarter length of the spacing of interface. No Splice connection should be placed at the centre of spacing or over the interface.



Note 30 Refer Figure 2 for definition of roof zones. The smallest spacing to be used for panels fall between two (or more) roof zones.

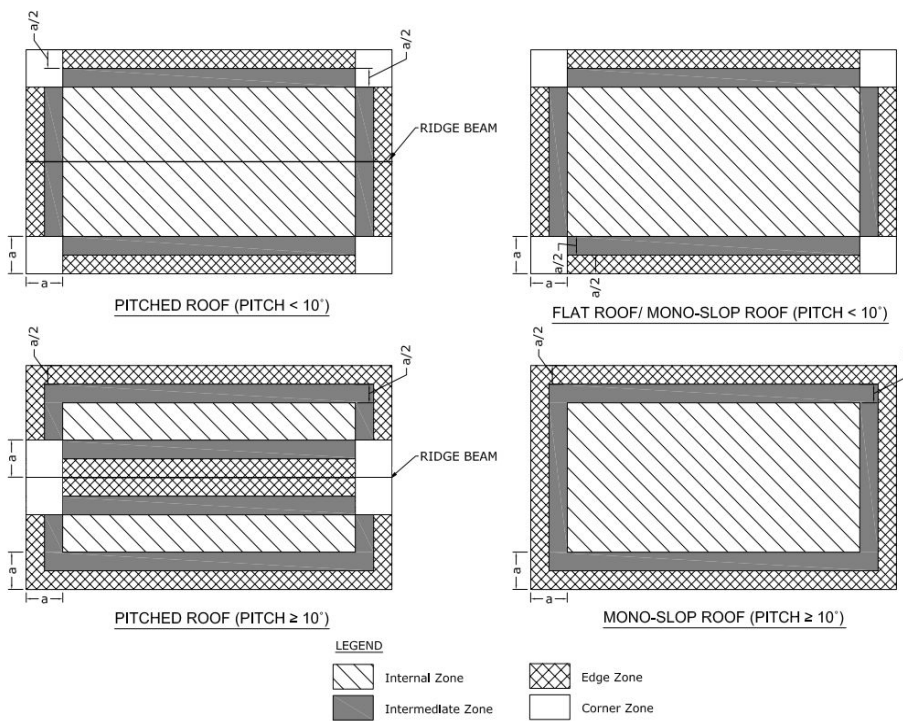

Figure 2- Roof Zones Definition

In Figure 2, the value of dimension "a" is the minimum of 0.2b or 0.2d, if (h/b) or (h/d) ≥ 0.2; or 2h if both (h/b) and (h/d) < 0.2 (b & d are building dimensions and h is average roof height, see Figure 1)

Note 31 Installation of solar array to be done in accordance with the relevant Clenergy PV installation manual. Contact Clenergy if you are unable to comply with any of the above installation specifications.

Relationships built on trust

Client: **CLEENERGY AUSTRALIA**
 Project: **Flush Array Frame System Spacing Table with ECO Rail - Tin & Tile Roof (Pierced Fix Roof) With Fasteners - 14g-10 TPI screws or approved equivalent within New Zealand**
 Address: **within New Zealand**

Job: **13708**
 Date: **Jan-25**
 Designed: **JD**
 Checked: **JG**

Examples

Example 1

Tin Roof		factor
Wind Region	NZ1	-
Terrain Category	2	-
Building Height	4m	-
h/d	0.75	-
Interface	ER-I-05	-
Panel Dimension	2m x 1m	
No. of Rails	2	1
Purlin Thickness	1.5mm	1
S_z	Fixing spacing for h/d=z = $S_{0.5} - [(S_{0.5} - S_{1.0}) / (1.0 - 0.5)] \times (z - 0.5)$	
$S_{0.5}$	Fixing spacing for h/d=0.5	
$S_{1.0}$	Fixing spacing for h/d=1.0	

Roof Zone	Spacing, h/d=0.5
Internal Zone	1880 mm
Intermediate Zone	1415 mm
Edge Zone	1030 mm
Corner Zone	665 mm

Roof Zone	Spacing, h/d=1
Internal Zone	1475 mm
Intermediate Zone	945 mm
Edge Zone	695 mm
Corner Zone	455 mm

Fixing spacing for h/d=0.75, $S_{0.75} = S_{0.5} - [(S_{0.5} - S_{1.0}) / (1.0 - 0.5)] \times (0.75 - 0.5)$

Final factor	1
Roof Zone	Final Spacing-mm
Internal Zone	1675
Intermediate Zone	1180
Edge Zone	860
Corner Zone	560

Example 2

Tin Roof		factor
Wind Region	NZ2, with Mlee of 1.2	-
Terrain Category	3	-
Building Height	12m	-
h/d	1.2	-
Interface	ER-I-05	-
Panel Dimension	1.75m x 1m	
No. of Rails	3	1.14
Purlin Thickness	1.9mm	1.00
Site Elevation	600m	0.80
Sub-alpine Region	N2 (E=600m)	-

Final factor	0.91
Roof Zone	Final Spacing-mm
Internal Zone	935
Intermediate Zone	610
Edge Zone	450
Corner Zone	--

Example 3

Tin Roof		factor
Wind Region	NZ3	-
Terrain Category	3	-
Building Height	5m	-
h/d	0.5	-
Interface	ER-I-25	-
Panel Dimension	2.1m x 1.1m	
No. of Rails	2	0.95
Purlin Thickness	2.4mm	1
Sub-alpine Region	N4 (E=200m)	*

Final factor	0.95
Roof Zone	Final Spacing -mm
Internal Zone	1490*
Intermediate Zone	1185
Edge Zone	865
Corner Zone	560

(From Note 26, the maximum spacing is 1490mm, which is determined by snow)

Example 4

Tile Roof		factor
Wind Region	NZ4	-
Terrain Category	3	-
Building Height	5m	-
h/d	0.5	-
Interface	ER-I-04	0.56
Panel Dimension	1.65m x 1.1m	
No. of Rails	2	1.04
Embedment F17	35mm	1.00
Sub-alpine Region	N5 (E=200m)	-
Minimum allowable spacing (1100/3=365)		*

Final factor	0.58
Roof Zone	Final Spacing -mm
Internal Zone	740
Intermediate Zone	455
Edge Zone	--*
Corner Zone	--*

Example 5

Tin Roof		factor
Wind Region	NZ2, with Mlee of 1.2	-
Terrain Category	3	-
Building Height	12m	-
h/d	1.1	-
Interface	ER-I-05	-
Panel Dimension	2.4m x 1.1m	
No. of Rails	2	0.82
Purlin Thickness	1.9mm	1.00
Site Elevation	700	0.76
Sub-alpine Region	N5 (E=700m)	-

Final factor	0.62
Roof Zone	Final Spacing-mm
Internal Zone	640
Intermediate Zone	415
Edge Zone	305
Corner Zone	--

(From Note 26, the maximum spacing is 1285mm, which is determined by snow)

Earthquake zone, Z 0.6 (Arthurs pass) -

(From Note 27, the maximum spacing is 1035mm, which is determined by earthquake)

Gamcorp Pty Ltd A.C.N 665 643 658 A.B.N 86 665 643 658
www.gamcorp.com.au melbourne@gamcorp.com.au
37 Butler St, Richmond VIC 3121
Tel: 03 9543 2211

Structural Design Documentation

Flush Array Frame System Spacing Table

According to AS/NZS 1170.2-2021

with ECO Rail – Tin Roof (Pierced Fix Roof)

with Fasteners - M8x150 hanger bolts or approved equivalent

within New Zealand

Terrain Category 2 & 3

For: CLENERGY AUSTRALIA
1/10 Duerdin St
Clayton, VIC 3168

Job Number: 13708 (Eco Rail & M8x150 hanger bolts)

Revision: 1

Date: 22 January 2025



COPYRIGHT: The concepts and information contained in this document are the property of Gamcorp Pty Ltd. Use or copying of this document in whole or in part without the written permission of Gamcorp constitutes an infringement of copyright.

LIMITATION: This report has been prepared on behalf of and for the exclusive use of Gamcorp Pty Ltd's Client, and is subject to and issued in connection with the provisions of the agreement between Gamcorp Pty Ltd and its Client. Gamcorp Pty Ltd accepts no liability or responsibility whatsoever for or in respect of any use of or reliance upon this report by any third party.

Gamcorp Pty Ltd A.C.N 665 643 658 A.B.N 86 665 643 658
www.gamcorp.com.au melbourne@gamcorp.com.au
37 Butler St, Richmond VIC 3121
Tel: 03 9543 2211

Job No: 13708

Client: CLENERGY AUSTRALIA

Project: Flush Array Frame System Spacing Table
with ECO Rail – Tin Roof (Pierced Fix Roof)
with Fasteners - M8x150 hanger bolts or approved equivalent

Address: within New Zealand

Wind Terrain Category: Terrain Category 2 & 3

Australian/New Zealand Standards

AS/NZS 1170.0:2002	Structural design actions Part 0: General principles
AS/NZS 1170.1:2002	Structural design actions Part 1: Permanent, imposed and other actions
AS/NZS 1170.2:2021	Structural design actions Part 2: Wind actions
AS/NZS 1170.3:2003	Structural design actions Part 3: Snow and ice actions
AS/NZS 1664.1:1997	Aluminium structures Part 1: Limit state design
AS/NZS 4600:2018	Cold-formed steel structures
AS 4100:2020	Steel structures
NZS 4219:2009	Seismic performance of engineering systems in buildings

Designed: JD

Checked: JG

Date: Jan-25

Relationships built on trust

Client: **CLENERGY AUSTRALIA**
 Project: **Flush Array Frame System Spacing Table**
with ECO Rail – Tin Roof (Pierced Fix Roof)
with Fasteners - M8x150 hanger bolts or approved equivalent
 Address: **within New Zealand**

Job: **13708**
 Date: **Jan-25**
 Designed: **JD**
 Checked: **JG**

Flush Array Frame System Spacing Table for Tin Roof (mm)

Type of Rail ER-R-ECO
 Type of Interface ER-I-05/ER-I-25
 Solar Panel Dimension 2mx1m
 Terrain category 2
 Fasteners to use with Fasteners - M8x150 hanger bolts or approved equivalent

h/d ≤ 0.5 *

Wind Region	Building Height - h (m)															
	h≤5				5<h≤10				10<h≤15				15<h≤20			
	Corner	Edge	Intermediate	Internal	Corner	Edge	Intermediate	Internal	Corner	Edge	Intermediate	Internal	Corner	Edge	Intermediate	Internal
NZ1&NZ2	845	1310	1615	1880	695	1065	1455	1765	625	960	1305	1695	590	905	1230	1660
NZ1&NZ2 with M _{lee} of 1.35	450	685	930	1440	--	565	765	1175	--	510	690	1060	--	480	650	995
NZ1&NZ2 with M _{lee} of 1.20	580	885	1205	1645	475	725	980	1520	430	655	885	1370	--	615	835	1285
NZ3	620	950	1295	1665	510	780	1055	1550	460	700	950	1470	435	660	895	1385
NZ4	675	1035	1410	1695	555	845	1150	1575	500	765	1035	1515	470	720	975	1485

h/d ≥ 1.0 *

Wind Region	Building Height - h (m)															
	h≤5				5<h≤10				10<h≤15				15<h≤20			
	Corner	Edge	Intermediate	Internal	Corner	Edge	Intermediate	Internal	Corner	Edge	Intermediate	Internal	Corner	Edge	Intermediate	Internal
NZ1&NZ2	575	880	1200	1640	475	720	980	1515	425	650	880	1360	--	615	830	1280
NZ1&NZ2 with M _{lee} of 1.35	--	470	630	970	--	--	520	795	--	--	470	715	--	--	445	675
NZ1&NZ2 with M _{lee} of 1.20	--	600	815	1255	--	495	665	1020	--	445	600	920	--	--	565	870
NZ3	--	645	875	1350	--	530	715	1100	--	480	645	990	--	450	610	930
NZ4	460	700	950	1470	--	575	780	1200	--	520	700	1075	--	490	665	1015

* For intermediate values of h/d ratios, linear interpolation shall be used. Refer Note 27 for definition h and d.

Flush Array Frame System Spacing Table for Tin Roof (mm)

Type of Rail ER-R-ECO
 Type of Interface ER-I-05/ER-I-25
 Solar Panel Dimension 2mx1m
 Terrain category **3**
 Fasteners to use with Fasteners - M8x150 hanger bolts or approved equivalent

$h/d \leq 0.5$ *

Wind Region	Building Height - h (m)															
	$h \leq 5$				$5 < h \leq 10$				$10 < h \leq 15$				$15 < h \leq 20$			
	Corner	Edge	Intermed iate	Internal	Corner	Edge	Intermed iate	Internal	Corner	Edge	Intermed iate	Internal	Corner	Edge	Intermed iate	Internal
NZ1&NZ2	1030	1550	1740	1995	1030	1550	1740	1995	885	1365	1645	1910	790	1215	1575	1840
NZ1&NZ2 with M_{lee} of 1.35	545	835	1135	1610	545	835	1135	1610	470	720	975	1515	--	645	870	1350
NZ1&NZ2 with M_{lee} of 1.20	700	1075	1470	1770	700	1075	1470	1770	605	925	1260	1670	540	825	1120	1600
NZ3	755	1160	1530	1795	755	1160	1530	1795	650	995	1355	1695	580	890	1210	1625
NZ4	815	1260	1555	1820	815	1260	1555	1820	705	1085	1475	1725	630	965	1315	1650

$h/d \geq 1.0$ *

Wind Region	Building Height - h (m)															
	$h \leq 5$				$5 < h \leq 10$				$10 < h \leq 15$				$15 < h \leq 20$			
	Corner	Edge	Intermed iate	Internal	Corner	Edge	Intermed iate	Internal	Corner	Edge	Intermed iate	Internal	Corner	Edge	Intermed iate	Internal
NZ1&NZ2	700	1070	1465	1765	700	1070	1465	1765	600	920	1255	1670	535	820	1115	1600
NZ1&NZ2 with M_{lee} of 1.35	--	570	770	1185	--	570	770	1185	--	490	665	1015	--	440	595	905
NZ1&NZ2 with M_{lee} of 1.20	475	730	985	1530	475	730	985	1530	--	630	850	1310	--	560	760	1165
NZ3	515	785	1065	1550	515	785	1065	1550	445	675	915	1415	--	605	815	1260
NZ4	555	850	1155	1575	555	850	1155	1575	480	735	995	1495	430	655	885	1370

* For intermediate values of h/d ratios, linear interpolation shall be used. Refer Note 27 for defination h and d.

Client: **CLENERGY AUSTRALIA**
 Project: **Flush Array Frame System Spacing Table with ECO Rail – Tin Roof (Pierced Fix Roof) with Fasteners - M8x150 hanger bolts or approved equivalent within New Zealand**
 Address: **within New Zealand**

Job: **13708**
 Date: **Jan-25**
 Designed: **JD**
 Checked: **JG**

General Notes

Note 1 Following components are satisfied to use according to AS/NZS 1170.2:2021

Components	Part Number	Description
ECO Rail	ER-R-ECO, ER-R-ECO/BA	As per drawing or test report provided by client
ECO Rail Splice	ER-SP-ECO, ER-SP-ECO/BA	
Standard Inter Clamp	ER-IC-ST, ER-IC-ST/BA	
Standard End Clamp	ER-EC-ST, ER-EC-ST/BA	
Zano Inter Clamp	ER-IC-28/42/L50/G/BA	
Zano End Clamp	ER-EC-28/42/L50/BA	
Universal Clamp	C-U/30/46, C-U/30/46/BA	
Universal Clamp with Grounding Clip	C-U/30/46-G, C-U/30/46-G/BA	
Tin Interface	ER-I-05, ER-I-05/BA, ER-I-05/CM, ER-I-25, ER-I-25/BA	
Tin Interface A with ezClick	ER-I-05A/EZC/ECO	
Hanger bolt for wood / metal purlin	ER-HB-MP/8/150RP, ER-HB-8/150	
Corrugated Roof adapter	EZ-AD-C43, EZ-AD-C43/BA	

Note 2 Tin roof interface spacing calculated based on 1.5mm steel purlin G450 or 35mm screw embedment into F7 (Pine) timber (JD4 seasoned timber).

Recommended screws

Metal Purlins/Battens	Fasteners to use
0.42mm to 0.75mm (G550)	M8x150 hanger bolts or approved equivalent
1.2mm to 2.4mm (G450)	M8x150 hanger bolts or approved equivalent
Timber Purlins/Battens/Rafters	Fasteners to use
Softwood F7 (Pine) (JD4 seasoned timber)	M8x150 hanger bolts or approved equivalent
Hardwood F17 (JD3 seasoned timber)	M8x150 hanger bolts or approved equivalent

Note 3 Maximum uplift wind pressure is limited to 5kPa.

Note 4 Deflection is limited to Minimum of L/120 and 15mm.

Note 5 Panels to be installed parallel to the roof surface.

Note 6 "--" states NOT SUITABLE FOR INSTALLATION.

Note 7 Terrain category definition according to section 4.2.1 of AS/NZS 1170.2:2021 as follows:

Terrain Category 2 (TC2) - Open terrain, including grassland, with well-scattered obstructions having heights generally from 1.5 m to 5 m, with no more than two obstructions per hectare (e.g. farmland and cleared subdivisions with isolated trees and uncut grass).
 Terrain Category 3 (TC3) - Terrain with numerous closely spaced obstructions having heights generally from 3 m to 10 m. The minimum density of obstructions shall be at least the equivalent of 10 house-size obstructions per hectare (e.g. suburban housing, light industrial estates or dense forests).

Note 8 Wind regions are shown in Figure 3.1(B) of AS/NZS 1170.2:2021.

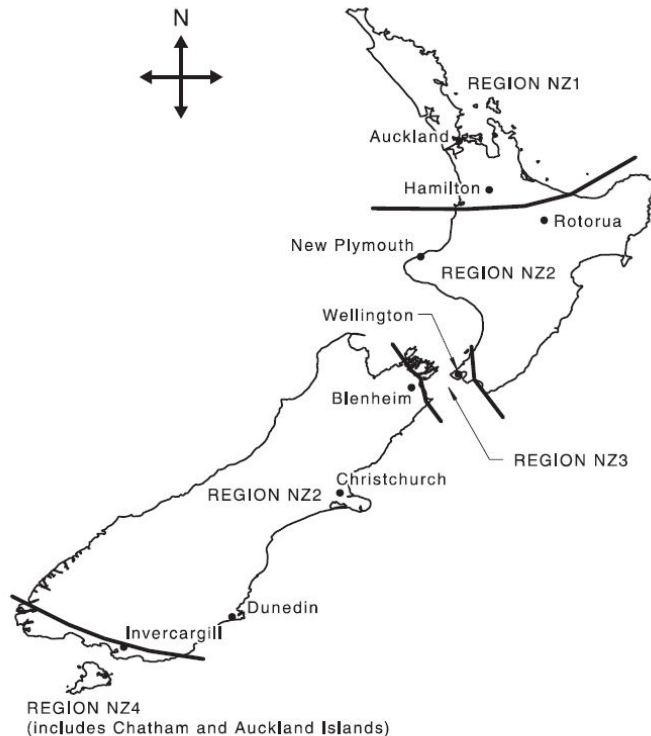

Figure 3.1(B) — Wind regions — New Zealand

Note 9 Base interface spacing to be multiplied by all applicable reduction/increase factors. Factored spacing less than one third of the panel width are not satisfied. (NOT SUITABLE FOR INSTALLATION)

Relationships built on trust

Client: **CLENERGY AUSTRALIA**
 Project: **Flush Array Frame System Spacing Table with ECO Rail – Tin Roof (Pierced Fix Roof) with Fasteners - M8x150 hanger bolts or approved equivalent within New Zealand**
 Address: **within New Zealand**

Job: **13708**
 Date: **Jan-25**
 Designed: **JD**
 Checked: **JG**

- Note 10 Wind direction multiplier (Md), Shielding multiplier (Ms) and Hill shape multiplier (Mh) are taken as 1.0.
- Note 11 Refer section 4.4 of AS/NZS 1170.2:2021 for Lee multiplier (Mlee) and topographic multiplier (Mt).
- Note 12 Lee multiplier (Mlee) is taken as 1.0 except for WR NZ1&NZ2 with Mlee which is taken as 1.35 and 1.2 separately. Refer section 4.4.1 of AS/NZS 1170.2:2021 for topographic multiplier (Mt). See Note 24 for Lee zones map.
- Note 13 The assessment includes the effect of earthquake loads. See note 26 for the fixing spacing determined by earthquake loads.
- Note 14 Alpine regions are excluded for snow assessment. See note 25 for the fixing spacing determined by snow loads.
- Note 15 Refer section 2.3 and Figure 2.2 of AS/NZS 1170.3:2003 for sub-alpine regions. Probability factor (kp) and Exposure reduction coefficient (Ce) are taken as 1.0 and Shape coefficient (μi) is taken as 0.7. See Note 26 for sub-alpine regions map.
- Note 16 Maximum panel weight is limited to 15kg/m².
- Note 17 Maximum panel width is limited to 1200mm.
- Note 18 Maximum rail and panel width overhang is limited to the 40% of the allowable interface spacing.
- Note 19 PV panels clamping zone to be according to the manufacturer's specifications.
- Note 20 This certificate is applicable for the corrosion zones C1, C2, C3, C4 and C5. Correspondent roof interface must be used for each zone. Refer SNZ TS 3404:2018 for corrosion zones definitions.
- Note 21 This assessment is based on the capacity of the fixings of array frame to the structure and the array frame itself but not PV panel nor roof structures. Other building structures are deemed to be satisfactory. It is the responsibility of the installer to adopt the most critical spacing.
- Note 22 Following reduction/increase factors to be applied to the base spacing for different type of tophat, purlin or batten or if timber screw embedment is reduced by using EZ-AD-C43 adaptor or fixing to smaller timber depth. **In any case, it is not applicable for installation if the actual fixing spacing after applying spacing ratio is less than 300mm.**

Purlin/Batten Material	Fixing Type		Purlin thickness (mm)	Min. Embedment (mm)	Spacing Reduction / Increase				
	Interface	No. of screws			WR NZ1&NZ2	WR NZ1&NZ2 with M _{lee} = 1.35	WR NZ1&NZ2 with M _{lee} = 1.20	WR NZ3	WR NZ4
Timber F7 (Pine)	Tin	1	-	25	-23%	-23%	-23%	-23%	-23%
Timber F7 (Pine)	Tin	1	-	30	-6%	-6%	-6%	-6%	-6%
Timber F7 (Pine)	Tin	1	-	35	0%	0%	0%	0%	0%
Timber F17 (HW)	Tin	1	-	25	0%	0%	0%	0%	0%
Timber F17 (HW)	Tin	1	-	30	0%	0%	0%	0%	0%
Timber F17 (HW)	Tin	1	-	35	0%	0%	0%	0%	0%
Metal (G550)	Tin	1	0.42	-	-80%	-100%	-100%	-80%	-80%
Metal (G550)	Tin	1	0.48	-	-75%	-100%	-75%	-75%	-75%
Metal (G550)	Tin	1	0.55	-	-70%	-100%	-70%	-70%	-70%
Metal (G550)	Tin	1	0.75	-	-60%	-60%	-60%	-60%	-60%
Metal (G450)	Tin	1	1.2	-	-21%	-21%	21%	-21%	-21%
Metal (G450)	Tin	1	1.5	-	0%	0%	0%	0%	0%
Metal (G450)	Tin	1	1.9	-	0%	0%	0%	0%	0%
Metal (G450)	Tin	1	2.4	-	0%	0%	0%	0%	0%

- Note 23 Following reduction/increase factors to be applied to the base spacing for different panel lengths. **In any case, the actual fixing spacing after applying spacing ratio is limited to maximum 2000mm**

Panel Length (mm)	No. of Rails	Spacing Reduction / Increase				
		WR NZ1&NZ2	WR NZ1&NZ2 with M _{lee} = 1.35	WR NZ1&NZ2 with M _{lee} = 1.20	WR NZ3	WR NZ4
1700	2	+4%	+6%	+5%	+4%	+4%
	3	+6%	+19%	+13%	+11%	+10%
	4	+6%	+24%	+13%	+11%	+10%
1800	2	+3%	+4%	+3%	+3%	+2%
	3	+6%	+17%	+13%	+11%	+10%
	4	+6%	+24%	+13%	+11%	+10%
1900	2	+1%	+2%	+2%	+1%	+1%
	3	+6%	+15%	+13%	+11%	+10%
	4	+6%	+24%	+13%	+11%	+10%
2000	2	0%	0%	0%	0%	0%
	3	+6%	+14%	+11%	+11%	+10%
	4	+6%	+22%	+13%	+11%	+10%
2100	2	-5%	-5%	-5%	-5%	-5%
	3	+9%	+12%	+10%	+9%	+9%
	4	+17%	+21%	+18%	+18%	+17%
2200	2	-10%	-10%	-10%	-10%	-10%
	3	+8%	+11%	+8%	+8%	+8%
	4	+16%	+19%	+17%	+16%	+16%
2300	2	-14%	-14%	-14%	-14%	-14%
	3	+7%	+9%	+7%	+7%	+7%
	4	+15%	+18%	+15%	+15%	+15%
2400	2	-18%	-18%	-18%	-18%	-18%
	3	+6%	+8%	+6%	+6%	+6%
	4	+6%	+17%	+13%	+11%	+10%

Relationships built on trust

Client: **CLENERGY AUSTRALIA**
 Project: **Flush Array Frame System Spacing Table with ECO Rail – Tin Roof (Pierced Fix Roof) with Fasteners - M8x150 hanger bolts or approved equivalent within New Zealand**
 Address: **within New Zealand**

Job: **13708**
 Date: **Jan-25**
 Designed: **JD**
 Checked: **JG**

Note 24 Interface spacing to be reduced as follows for sites in wind regions NZ1 & NZ2 with Mlee over 500m above sea level:

Site Elevation, E (m)	Spacing Reduction
E < 500	0%
500 ≤ E < 700	-20%
700 ≤ E < 900	-24%
900 ≤ E < 1200	-31%
E ≥ 1200	N/A

North Island	
1	Kaimai
2	Taranaki
3	Ruapehu
4	Tararua
5	Tararua and Orongorongo
6	Coastal Wairarapa
South Island	
7	West Coast North
8	West Coast Alps
9	Awatere
10	Inland Kaikoura
11	Southern Alps
12	Hunter
13	Hakataramea
14	St Mary's
15	Pisa
16	Dunstan
17	Rock and Pillar

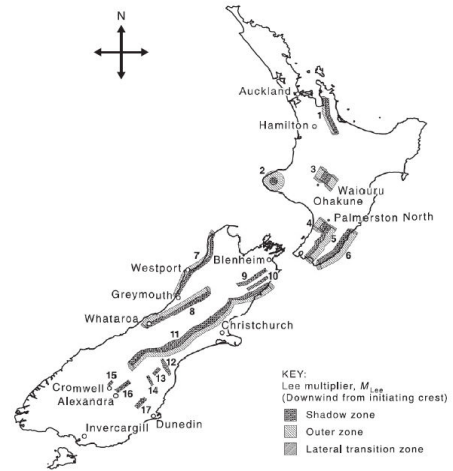

NOTE 1 Some outer and lateral transition zones are not shown.
 NOTE 2 For numbers shown, see the first column of Table 4.4.

Figure 4.6 — Locations of New Zealand lee zones

Note 25 Maximum Tin interface spacing in sub-alpine regions to be limited to follows for all roof zones must be checked separately before using these limitations).

Site Elevation, E (m)	No. of Rails	Maximum Interface Spacing (mm)			
		Snow Region N1	Snow Region N2&N3	Snow Region N4	Snow Region N5
E ≤ 100	2	N/A	N/A	N/A	1775
	3				1970
	4				2120
100 < E ≤ 200	2	N/A	N/A	N/A	1775
	3				1970
	4				2120
200 < E ≤ 300	2	N/A	N/A	N/A	1775
	3				1970
	4				2120
300 < E ≤ 400	2	N/A	N/A	N/A	1775
	3				1970
	4				2120
400 < E ≤ 500	2	N/A	N/A	N/A	1775
	3				1970
	4				2120
500 < E ≤ 700	2	N/A	N/A	N/A	1775
	3				1970
	4				2120
700 < E ≤ 900	2	N/A	N/A	N/A	1775
	3				1970
	4				2120
900 < E ≤ 1200	2	N/A	N/A	N/A	1775
	3				1970
	4				2120

2.3 NEW ZEALAND

Alpine and sub-alpine regions are defined as follows:

(a) N1 (southern portion of North Island of New Zealand, see Figure 2.2):

- (i) Sub-alpine between 400 m and 1200 m.
- (ii) Alpine ≥1200 m.

(b) N2 (South Island of New Zealand):

- (i) Sub-alpine between 200 m and 900 m.
- (ii) Alpine ≥900 m.

(c) N3 (South Island of New Zealand):

- (i) Sub-alpine between 150 m and 900 m.
- (ii) Alpine ≥900 m.

(d) N4 and N5 (South Island of New Zealand):

- (i) Sub-alpine <900 m.
- (ii) Alpine ≥900 m.

NOTE: This map is approximate only and altitude above mean sea level shall be used to determine snow region. For sub-alpine regions in the South Island (N2, N3, N4 and N5) the regions coincide with the 1988 county boundaries. Where an alpine region exists between sub-alpine regions, the alpine region separates the 2 sub-alpine regions (which extend downwards from 1200 m altitude).

FIGURE 2.2 NEW ZEALAND—APPROXIMATE LOCATIONS OF ALPINE AND SUB-ALPINE REGIONS

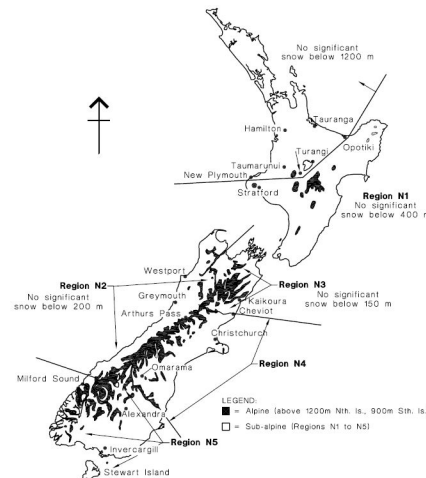

Client: **CLENERGY AUSTRALIA**
 Project: **Flush Array Frame System Spacing Table with ECO Rail – Tin Roof (Pierced Fix Roof) with Fasteners - M8x150 hanger bolts or approved equivalent**
 Address: **within New Zealand**

Job: **13708**
 Date: **Jan-25**
 Designed: **JD**
 Checked: **JG**

Note 26 Refer section 3.4.1 and Figure 2 of NZS 4219:2009 for zone factor (Z). Performance factor (Cp) is taken as 0.85 and Component risk factor (Rc) coefficient (Ce) is taken as 1.0 and High coefficient (Ch) is taken as 3. Maximum Tin roof interface spacing in Earthquake zone to be limited to follows for all roof zones.

Earthquake Factor, Z	No. of Rails	Maximum Interface Spacing (mm)				
		Max Panel Length 2000mm	Max Panel Length 2100mm	Max Panel Length 2200mm	Max Panel Length 2300mm	Max Panel Length 2400mm
Z ≤ 0.13	2	2000	2000	2000	2000	2000
	3	2000	2000	2000	2000	2000
0.13 < Z ≤ 0.15	2	2000	2000	2000	2000	1980
	3	2000	2000	2000	2000	2000
0.15 < Z ≤ 0.18	2	1980	1960	1935	1915	1895
	3	2000	2000	2000	2000	2000
0.18 < Z ≤ 0.20	2	1930	1905	1885	1865	1845
	3	2000	2000	2000	2000	2000
0.20 < Z ≤ 0.23	2	1865	1845	1820	1800	1775
	3	2000	2000	2000	1995	1970
0.23 < Z ≤ 0.26	2	1805	1780	1755	1730	1705
	3	2000	1975	1955	1930	1910
0.26 < Z ≤ 0.30	2	1725	1700	1675	1650	1625
	3	1930	1905	1885	1865	1845
0.30 < Z ≤ 0.35	2	1640	1615	1590	1565	1545
	3	1860	1835	1815	1795	1770
0.35 < Z ≤ 0.40	2	1570	1545	1520	1500	1475
	3	1795	1770	1740	1715	1690
0.40 < Z ≤ 0.45	2	1510	1485	1460	1440	1385
	3	1725	1700	1675	1650	1625
0.45 < Z ≤ 0.50	2	1455	1425	1360	1300	1245
	3	1670	1640	1615	1590	1570
0.50 < Z ≤ 0.55	2	1360	1295	1235	1180	1130
	3	1615	1590	1565	1540	1520
0.55 < Z ≤ 0.60	2	1245	1185	1130	1080	1035
	3	1570	1545	1520	1500	1475

Note:
 The seismic assessment is based on the rail capacity and shear capacity of fixings.

Table 3 – Zone factors for New Zealand locations (north to south)

#	Location	Z	#	Location	Z
1	Kaitiaki	0.13	36	Taupo	0.28
2	Paihia/Russell	0.13	37	Taumarunui	0.21
3	Kaikohe	0.13	38	Turangi	0.27
4	Whangarei	0.13	39	Gisborne	0.36
5	Dargaville	0.13	40	Wairoa	0.37
6	Warkworth	0.13	41	Waikare	0.18
7	Auckland	0.13	42	New Plymouth	0.18
8	Manakau City	0.13	43	Inglewood	0.18
9	Waikuku	0.13	44	Stratford	0.18
10	Pukekohe	0.13	45	Opunake	0.18
11	Thames	0.16	46	Hawera	0.18
12	Paeroa	0.18	47	Patea	0.19
13	Waihi	0.18	48	Raetihi	0.26
14	Huntly	0.15	49	Ohakune	0.27
15	Ngaruawahia	0.15	50	Waikou	0.29
16	Morrinsville	0.18	51	Napier	0.38
17	Te Aroha	0.18	52	Hastings	0.39
18	Tauranga	0.20	53	Wanganui	0.25
19	Mount Maunganui	0.20	54	Waipawa	0.41
20	Hamilton	0.16	55	Waipukurau	0.41
21	Cambridge	0.18	56	Taihape	0.33
22	Te Awamutu	0.17	57	Marton	0.30
23	Matamata	0.19	58	Bulls	0.31
24	Te Puke	0.22	59	Fallding	0.37
25	Putaruru	0.21	60	Palmerston North	0.38
26	Tokoroa	0.21	61	Dannevirke	0.42
27	Otorohanga	0.17	62	Woodville	0.41
28	Te Kuiti	0.18	63	Pahiatua	0.42
29	Mangakino	0.21	64	Foxton/Foxton Beach	0.36
30	Rotorua	0.24	65	Levin	0.40
31	Kawerau	0.29	66	Otaki	0.40
32	Whakatane	0.30	67	Waikanae	0.40
33	Opotiki	0.30	68	Paraparaumu	0.40
34	Ruatoria	0.33	69	Masterton	0.42
35	Murupara	0.30			

Table 3 – Zone factors for New Zealand locations (north to south) (continued)

#	Location	Z	#	Location	Z
70	Porirua	0.40	102	Christchurch	0.22
71	Wellington CBD (north of Basin Reserve)	0.40	103	Geraldine	0.19
72	Wellington	0.40	104	Ashburton	0.20
73	Hutt Valley – south of Taika Gorge	0.40	105	Fairlie	0.24
74	Upper Hutt	0.42	106	Temuka	0.17
75	Eastbourne – Point Howard	0.40	107	Timaru	0.15
76	Wairuomata	0.40	108	Mt Cook	0.38
77	Takaka	0.23	109	Twizel	0.27
78	Motueka	0.26	110	Waimate	0.14
79	Nelson	0.27	111	Cromwell	0.24
80	Picton	0.30	112	Wanaka	0.30
81	Blenheim	0.33	113	Arrowtown	0.30
82	St Arnaud	0.36	114	Alexandra	0.21
83	Westport	0.30	115	Queenstown	0.32
84	Reefton	0.37	116	Milford Sound	0.54
85	Murchison	0.34	117	Palmerston	0.13
86	Springs Junction	0.45	118	Oamaru	0.13
87	Hammer Springs	0.55	119	Dunedin	0.13
88	Seddon	0.40	120	Mosgiel	0.13
89	Ward	0.40	121	Riverton	0.20
90	Cheviot	0.40	122	Te Anau	0.36
91	Greymouth	0.37	123	Gore	0.18
92	Kaikoura	0.42	124	Winton	0.20
93	Haritahi	0.46	125	Balclutha	0.13
94	Hokitika	0.45	126	Mataura	0.17
95	Fox Glacier	0.44	127	Bluff	0.15
96	Franz Josef	0.44	128	Invercargill	0.17
97	Otira	0.60	129	Oban	0.14
98	Arthurs Pass	0.60			
99	Rangiora	0.33			
100	Darfield	0.30			
101	Akaroa	0.16			

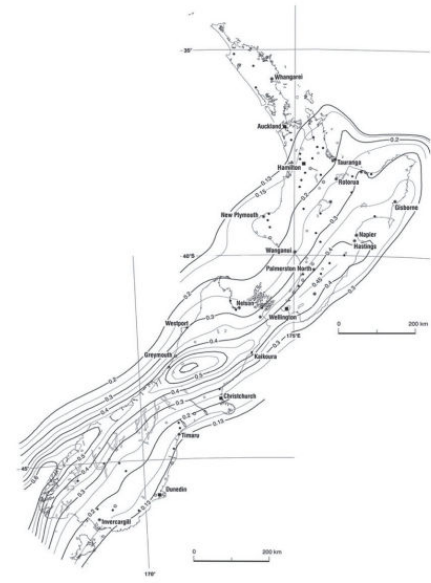

Figure 2 – Zone factor, Z

Client: **CLENERGY AUSTRALIA**
 Project: **Flush Array Frame System Spacing Table with ECO Rail – Tin Roof (Pierced Fix Roof) with Fasteners - M8x150 hanger bolts or approved equivalent within New Zealand**
 Address: **within New Zealand**

Job: **13708**
 Date: **Jan-25**
 Designed: **JD**
 Checked: **JG**

Note 27 Building height is average roof height of structure above ground. Refer Figure 1 for definition of h, d and b.

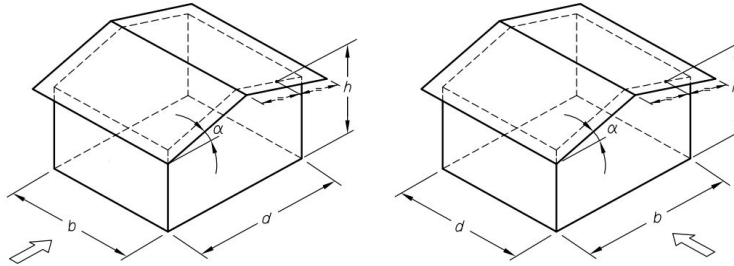
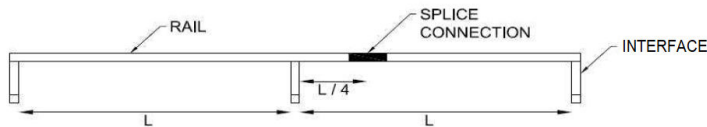

Figure 1 – h, d and b definition

Note 28 Rail splice connection must be placed at a quarter length of the spacing of interface. No Splice connection should be placed at the centre of spacing or over the interface.



Note 29 Refer Figure 2 for definition of roof zones. The smallest spacing to be used for panels fall between two (or more) roof zones.

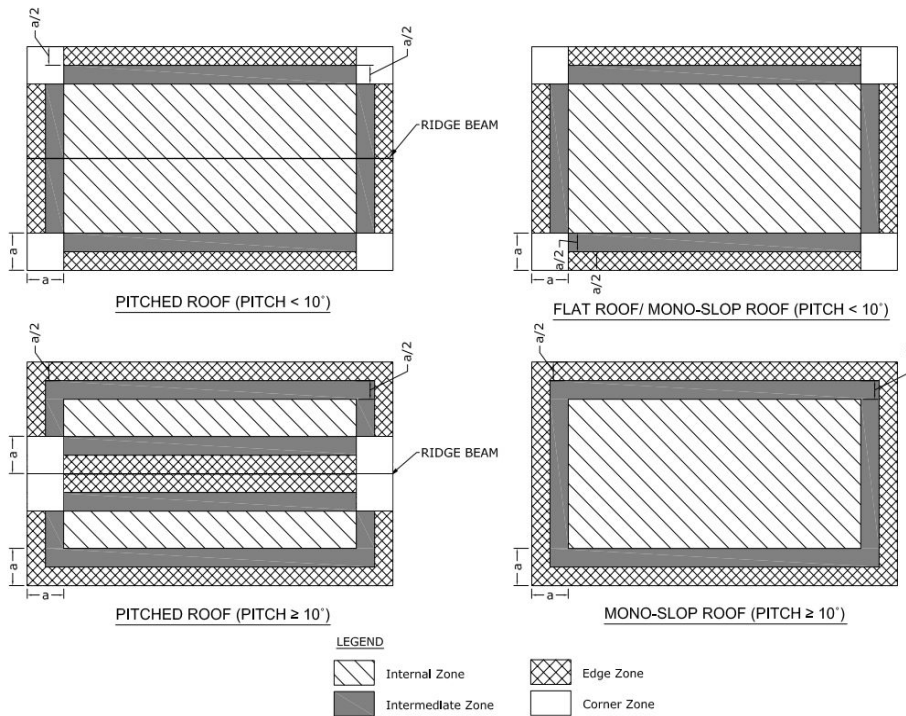

Figure2- Roof Zones Definition

In Figure 2, the value of dimension "a" is the minimum of 0.2b or 0.2d, if (h/b) or (h/d) ≥ 0.2; or 2h if both (h/b) and (h/d) < 0.2 (b & d are building dimensions and h is average roof height, see Figure 1)

Note 30 Installation of solar array to be done in accordance with the relevant Clenergy PV installation manual. Contact Clenergy if you are unable to comply with any of the above installation specifications.

Relationships built on trust

Client: **CLENERGY AUSTRALIA**
 Project: **Flush Array Frame System Spacing Table with ECO Rail – Tin Roof (Pierced Fix Roof) with Fasteners - M8x150 hanger bolts or approved equivalent within New Zealand**
 Address: **within New Zealand**

Job: **13708**
 Date: **Dec-99**
 Designed: **JD**
 Checked: **JG**

Examples

Example 1

Tin Roof		factor
Wind Region	NZ1	-
Terrain Category	2	-
Building Height	4m	-
h/d	0.75	-
Interface	ER-I-05	-
Panel Dimension	2m x 1m	
No. of Rails	2	1
Purlin Thickness	1.5mm	1
S_z	Fixing spacing for h/d=z	
	$= S_{0.5} - [(S_{0.5} - S_{1.0}) / (1.0 - 0.5)] \times (z - 0.5)$	
$S_{0.5}$	Fixing spacing for h/d=0.5	
$S_{1.0}$	Fixing spacing for h/d=1.0	

Roof Zone	Spacing, h/d=0.5
Internal Zone	1880 mm
Intermediate Zone	1615 mm
Edge Zone	1310 mm
Corner Zone	845 mm

Roof Zone	Spacing, h/d=1
Internal Zone	1640 mm
Intermediate Zone	1220 mm
Edge Zone	880 mm
Corner Zone	575 mm

Fixing spacing for h/d=0.75, $S_{0.75} = S_{0.5} - [(S_{0.5} - S_{1.0}) / (1.0 - 0.5)] \times (0.75 - 0.5)$

Roof Zone	Spacing, h/d=0.75
Internal Zone	1760 mm
Intermediate Zone	1417.5 mm
Edge Zone	1095 mm
Corner Zone	710 mm

Final factor	Final Spacing-mm
Final factor	1
Roof Zone	Final Spacing-mm
Internal Zone	1760
Intermediate Zone	1415
Edge Zone	1095
Corner Zone	710

Example 2

Tin Roof		factor
Wind Region	NZ2, with Mlee of 1.2	-
Terrain Category	3	-
Building Height	12m	-
h/d	1.2	-
Interface	ER-I-05	-
Panel Dimension	1.75m x 1m	
No. of Rails	3	1.13
Purlin Thickness	1.9mm	1.00
Site Elevation	600m	0.80
Sub-alpine Region	N2 (E=600m)	-

Final factor	Final Spacing-mm
Final factor	0.9
Roof Zone	Final Spacing-mm
Internal Zone	1180
Intermediate Zone	765
Edge Zone	565
Corner Zone	--

Example 3

Tin Roof		factor
Wind Region	NZ3	-
Terrain Category	3	-
Building Height	5m	-
h/d	0.5	-
Interface	ER-I-25	-
Panel Dimension	2.1m x 1.1m	
No. of Rails	2	0.95
Purlin Thickness	2.4mm	1
Sub-alpine Region	N4 (E=200m)	*

Final factor	Final Spacing -mm
Final factor	0.95
Roof Zone	Final Spacing -mm
Internal Zone	1490*
Intermediate Zone	1450
Edge Zone	1100
Corner Zone	715

(From Note 25, the maximum spacing is 1490mm, which is determined by snow)

Example 4

Tin Roof		factor
Wind Region	NZ2, with Mlee of 1.2	-
Terrain Category	3	-
Building Height	12m	-
h/d	1.1	-
Interface	ER-I-05	-
Panel Dimension	2.4m x 1.1m	
No. of Rails	2	0.82
Purlin Thickness	1.9mm	1.00
Site Elevation	700	0.76
Sub-alpine Region	N5 (E=700m)	-

Final factor	Final Spacing-mm
Final factor	0.62
Roof Zone	Final Spacing-mm
Internal Zone	815
Intermediate Zone	530
Edge Zone	390
Corner Zone	--

(From Note 25, the maximum spacing is 1285mm, which is determined by snow)

Earthquake zone, Z 0.6 (Arthurs pass) -
 (From Note 26, the maximum spacing is 1035mm, which is determined by earthquake)

Certificate User Guideline



association of
consulting and
engineering

Building Code Clause(s) B1

PRODUCER STATEMENT – PS1 – DESIGN

ISSUED BY: Gamcorp Pty Ltd
(Design Firm)

TO: Clenergy Australia
(Owner/Developer)

TO BE SUPPLIED TO:
(Building Consent Authority)

IN RESPECT OF: Clenergy PV-ezRack SolarRoof Flush and Tilt Roof Mount systems with ER-R-ECO & ER-R-ELT Penetrative fixing

AT: Within New Zealand
(Address)

Town/City: **LOT** **DP** **SO**
(Address)

We have been engaged by the owner/developer referred to above to provide:

The assessment according to the capacity of the fixing of the array frame to the roof structure and the array frame itself for roof top solar panel installation.
PV panel and building structure including roof structure are excluded.

(Extent of Engagement)

services in respect of the requirements of Clause(s) B1 of the Building Code for:

All or Part only (as specified in the attachment to this statement), of the proposed building work.

The design carried out by us has been prepared in accordance with:

Compliance Documents issued by the Ministry of Business, Innovation & Employment or
(verification method/acceptable solution)

Alternative solution as per the attached schedule. refer Certification Letter 13708-01(Eco Rail) & 13924-01(Elite Rail) for Flush Mount system & 13708-02 (Eco Rail) & 13924-02(Elite Rail) for Tilt Mount system

The proposed building work covered by this producer statement is described on the drawings titled:

..... and numbered together with the specification, and other documents set out in the schedule attached to this statement.

On behalf of the Design Firm, and subject to: refer Certification Letter 13708-01(Eco Rail) & 13924-01(Elite Rail) for Flush Mount system & 13708-02 (Eco Rail) & 13924-02(Elite Rail) for Tilt Mount system
(i) Site verification of the following design assumptions
(ii) All proprietary products meeting their performance specification requirements;

I believe on reasonable grounds that a) the building, if constructed in accordance with the drawings, specifications, and other documents provided or listed in the attached schedule, will comply with the relevant provisions of the Building Code and that b), the persons who have undertaken the design have the necessary competency to do so. I also recommend the following level of construction monitoring/observation:

CM1 CM2 CM3 CM4 CM5 (Engineering Categories)

I, L. Van Spaandonk am: CPEng # CMEngNZ 2003796
(Name of Design Professional)

I am a member of: Engineering New Zealand and hold the following qualifications: FIEAust CPEng NER APEC Engineer InIPE(Aus) CMEngNZ

The Design Firm issuing this statement holds a current policy of Professional Indemnity Insurance no less than \$200,000*.

The Design Firm is a member of ACE New Zealand:

SIGNED BY: L. Van Spaandonk (Signature)
(Name of Design Professional)

ON BEHALF OF Gamcorp Pty Ltd Date: 24/01/2025
(Design Firm)

Note: This statement shall only be relied upon by the Building Consent Authority named above. Liability under this statement accrues to the Design Firm only. The total maximum amount of damages payable arising from this statement and all other statements provided to the Building Consent Authority in relation to this building work, whether in contract, tort or otherwise (including negligence), is limited to the sum of \$200,000.*

This form is to accompany **Form 2 of the Building (Forms) Regulations 2004** for the application of a Building Consent.
THIS FORM AND ITS CONDITIONS ARE COPYRIGHT TO ACE NEW ZEALAND AND ENGINEERING NEW ZEALAND

GUIDANCE ON USE OF PRODUCER STATEMENTS

Producer statements were first introduced with the Building Act 1991. The producer statements were developed by a combined task committee consisting of members of the New Zealand Institute of Architects, Institution of Professional engineers New Zealand (now Engineering New Zealand), ACE New Zealand in consultation with the Building Officials Institute of New Zealand. The original suit of producer statements has been revised at the date of this form as a result of enactment of the Building Act (2004) by these organisations to ensure standard use within the industry.

The producer statement system is intended to provide Building Consent Authorities (BCAs) with reasonable grounds for the issue of a Building Consent or a Code Compliance Certificate, without having to duplicate design or construction checking undertaken by others.

PS1 Design Intended for use by a suitably qualified independent design professional in circumstances where the BCA accepts a producer statement for establishing reasonable grounds to issue a Building Consent;

PS2 Design Review Intended for use by a suitably qualified independent design professional where the BCA accepts an independent design professional's review as the basis for establishing reasonable grounds to issue a Building Consent;

PS3 Construction Forms commonly used as a certificate of completion of building work are Schedule 6 of NZS 3910:2013 or Schedules E1/E2 of NZIA's SCC 2011²

PS4 Construction Review Intended for use by a suitably qualified independent design professional who undertakes construction monitoring of the building works where the BCA requests a producer statement prior to issuing a Code Compliance Certificate.

This must be accompanied by a statement of completion of building work (Schedule 6).

The following guidelines are provided by ACE New Zealand and Engineering New Zealand to interpret the Producer Statement.

Competence of Design Professional

This statement is made by a Design Firm that has undertaken a contract of services for the services named, and is signed by a person authorised by that firm to verify the processes within the firm and competence of its designers.

A competent design professional will have a professional qualification and proven current competence through registration on a national competence based register as a Chartered Professional Engineer (CPEng).

Membership of a professional body, such as Engineering New Zealand (formerly IPENZ) provides additional assurance of the designer's standing within the profession. If the design firm is a member of ACE New Zealand, this provides additional assurance about the standing of the firm.

Persons or firms meeting these criteria satisfy the term "suitably qualified independent design professional".

*Professional Indemnity Insurance

As part of membership requirements, ACE New Zealand requires all member firms to hold Professional Indemnity Insurance to a minimum level.

The PI Insurance minimum stated on the front of this form reflects standard, small projects. If the parties deem this inappropriate for large projects the minimum may be up to \$500,000.

Professional Services during Construction Phase

There are several levels of service which a Design Firm may provide during the construction phase of a project (CM1-CM5 for Engineers³). The Building Consent Authority is encouraged to require that the service to be provided by the Design Firm is appropriate for the project concerned.

Requirement to provide Producer Statement PS4

Building Consent Authorities should ensure that the applicant is aware of any requirement for producer statements for the construction phase of building work at the time the building consent is issued as no design professional should be expected to provide a producer statement unless such a requirement forms part of the Design firm's engagement.

Attached Particulars

Attached particulars referred to in this producer statement refer to supplementary information appended to the producer statement.

Refer Also:

- 1 Conditions of Contract for Building & Civil Engineering Construction
NZS 3910: 2013
- 2 NZIA Standard Conditions of Contract SCC 2011

Guideline on the Briefing & Engagement for Consulting Engineering Services
(ACE New Zealand/Engineering New Zealand 2004)
- 4 PN Guidelines on Producer Statements

www.acenz.org.nz
www.engineeringnz.org



association of
consulting and
engineering



Clenergy





3/10 Duerdin St
Clayton VIC 3168
Australia

Phone: +61 3 9239 8088

Email: sales@clenergy.com.au

Web: www.clenergy.com.au

 @ClenergyGlobal / @ClenergyClub / @ClenergyAUS / @ClenergyThailand

 @Clenergy_global  @Clenergy  @Clenergy  @ClenergyClub

A Clenergy Technologies Company