

SolarRoof Penetrative Tilt Mounting with Elite Rail

Code-Compliant Planning and Installation Guide V 2.0 (New Zealand)
Complying with AS/NZS 1170.2-2021



Introduction

The Clenergy PVezRack® SolarRoof Tilt Legs has been developed as a universal PV-mounting system for roof-mounting on pitched and flat roofs. The use of patented aluminium base rails, Z-Module technology and telescopic mounting technology eliminates custom cutting and enables fast installation.

Please review this manual thoroughly before installing PVezRack® SolarRoof Tilt Legs. This manual provides:

- 1) Supporting documentation for building permit applications relating to PVezRack® SolarRoof Tilt Legs Universal PV Module Mounting System,
- 2) Planning and installation instructions.

List of contents

Introduction	01
Planning	02 - 14
Tools & Components	15
System Overview	16 - 19
Installation Instruction	20 -23
Certification	24
Certificate User Guideline	50

The PVezRack® SolarRoof Tilt Legs parts, when installed in accordance with this guide, will be structurally sound and will meet the AS/NZS 1170.2 - 2021 standard. During installation, and especially when working on the roof, please comply with the appropriate Occupational Health and Safety regulations. Please also pay attention to any other relevant State or Federal regulations. Please check that you are using the latest version of the Installation Manual, which you can do by contacting Clenergy Australia via email on sales@clenergy.com.au, or contacting your local distributor in New Zealand.

Product Warranty:

Please refer [PVezRack® Product Warranty](#) on our website.

The installer is solely responsible for:

- Complying with all applicable local or national building codes, including any updates that may supersede this manual;
- Ensuring that PV-ezRack and other products are appropriate for the particular installation and the installation environment;
- Using only PV-ezRack parts and installer-supplied parts as specified by PV-ezRack project plan (substitution of parts may void the warranty and invalidate the letter of certification);
- Recycling: Recycle according to the local relative statute;
- Removal: Reverse installation process;
- Ensuring that there are no less than two professionals working on panel installation;
- Ensuring the installation of related electrical equipment is performed by licenced electricians;
- Ensuring safe installation of all electrical aspects of the PV array, This includes adequate earth bonding of the PV array and PVezRack® SolarRoof components as required in AS/NZS 5033: 2021;
- Ensuring that the roof, its rafters/purlins, connections, and other structural support members can support the array under building live load conditions;
- Ensuring that screws to fix interfaces have adequate pullout strength and shear capacities as installed;
- Maintaining the waterproof integrity of the roof, including selection of appropriate flashing;
- Verifying the compatibility of the installation considering preventing electrochemical corrosion between dissimilar metals. This may occur between structures and the building and also between structures, fasteners and PV modules, as detailed in AS/NZS 5033: 2021;
- Verifying atmospheric corrosivity zone of installation site by referring to SNZ TS 3404:2018 or consulting local construction business to determine appropriate products and installations.

Planning

Determine the wind region of your installation site

Wind regions map below shows 4 different wind regions in New Zealand: NZ1, NZ2, NZ3 and NZ4.

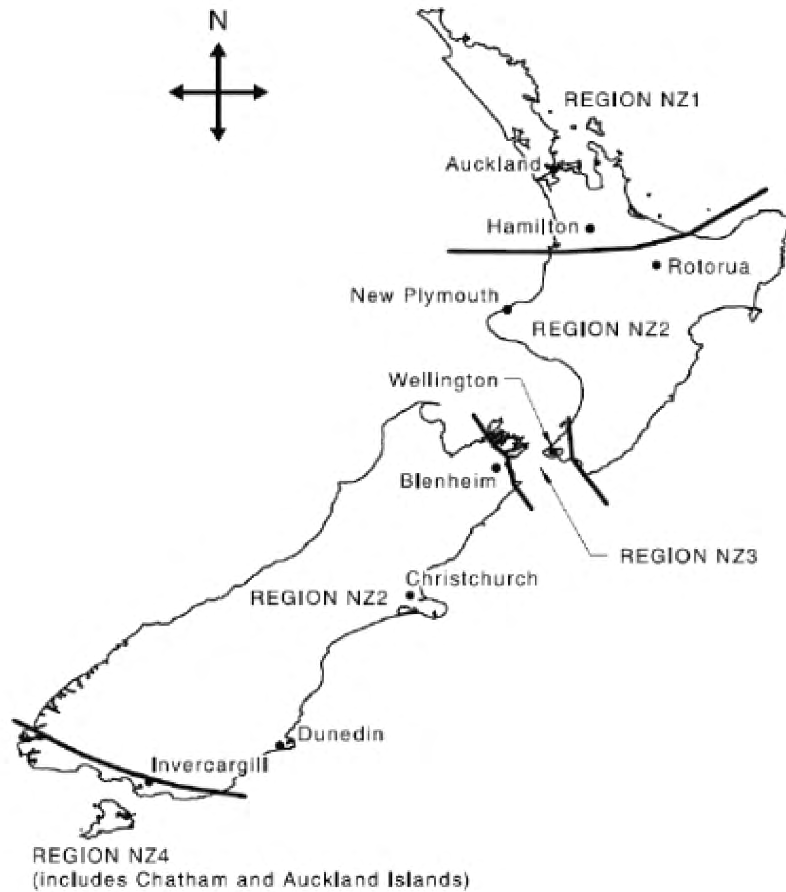

The lee (effect) multiplier (M_{1ee}) shall be evaluated for New Zealand sites in the lee zones below. In wind regions of NZ1 and NZ2 with M_{1ee} over 500 m above sea level, the interface spacing reduction is applied. Please refer to note 25 of engineering certificate.

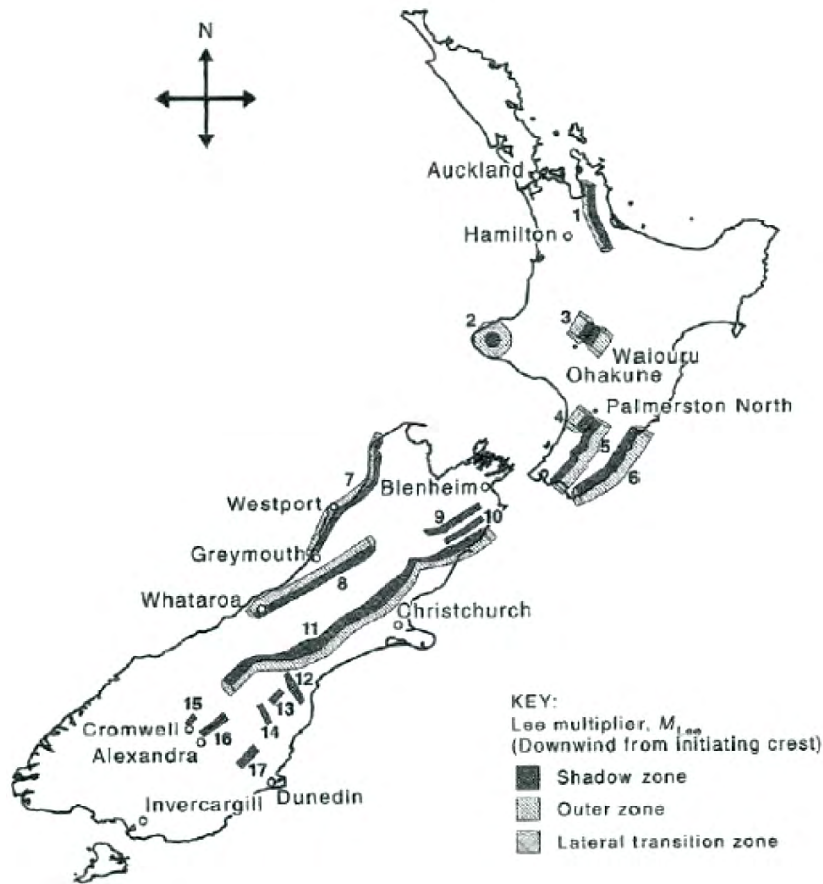

Locations of New Zealand lee Zones

For installation sites located in Sub-alpine Regions (shown on the map below), please refer to Note 26 of engineering certificate for maximum interface spacing and see “Examples” in certificate to understand how to use maximum spacing in Sub-alpine Regions.

If your installation site is in Alpine regions, please contact Clenergy to obtain a project specific engineering certificate to support your installation.

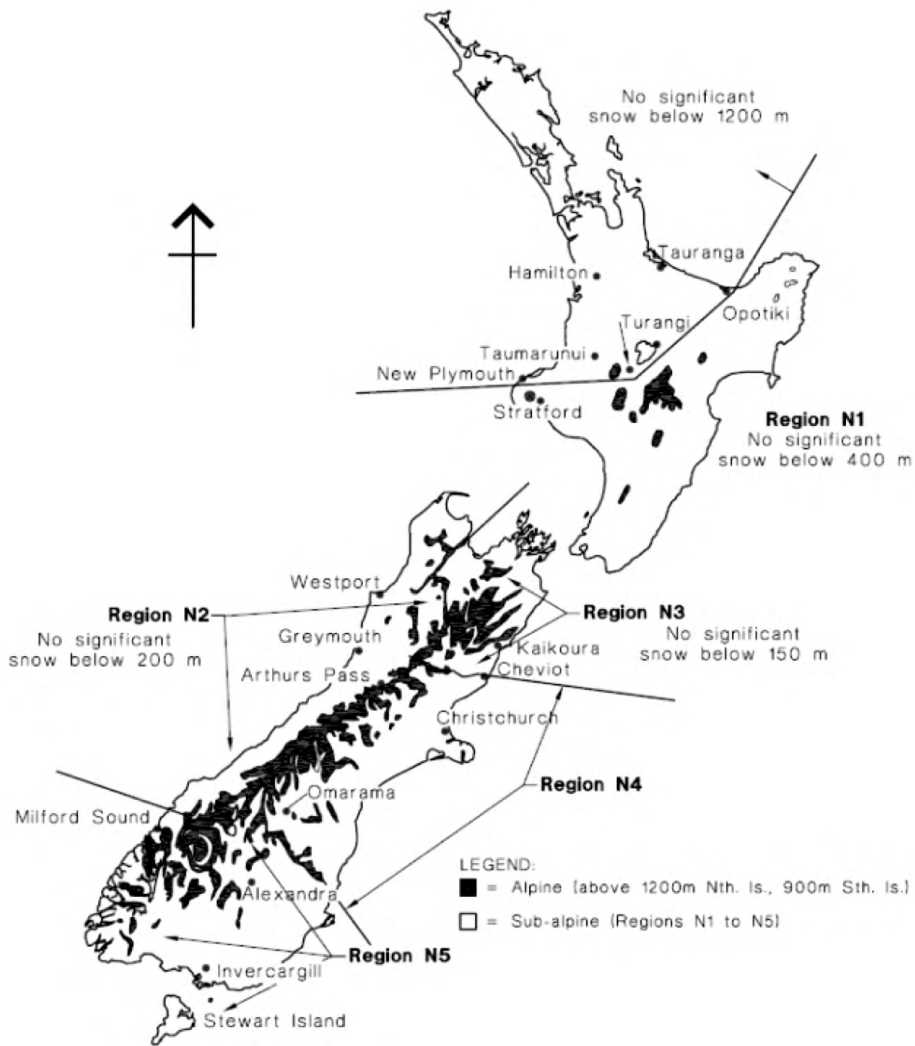

New Zealand – Approximate Locations of Alpine and Sub-alpine Regions

Determine the Terrain Category

It requires to determine the right terrain category to ensure the installation meets the maximum interface spacing specified in the engineering certificate.

Terrain Category 1 (TC1) – Very exposed open terrain with very few or no obstructions, and all water surfaces (e.g. flat, treeless, poorly grassed plains; open ocean, rivers, canals, bays and lakes).

Terrain Category 2 (TC2) – Open terrain, including grassland, with well-scattered obstructions having heights generally from 1.5 m to 5 m, with no more than two obstructions per hectare (e.g. farmland and cleared subdivisions with isolated trees and uncut grass).

Terrain Category 3 (TC3) – Terrain with numerous closely spaced obstructions having heights generally from 3 m to 10 m. The minimum density of obstructions shall be at least the equivalent of 10 house-size obstructions per hectare (e.g. suburban housing, light industrial estates or dense forests).

Terrain Category 4 (TC4) – Terrain with numerous large, high (10 m to 30 m tall) and closely spaced constructions, such as large city centres and well-developed industrial complexes.

If your installation site is not at TC 2 or 3, please contact Clenergy to obtain a project specific engineering certificate to support your installation.

Verify Atmospheric Corrosivity Zone of Installation Site

Please refer “SNZ TS 3404:2018 Durability Requirements for Steel Structures and Components” or consult local construction business to verify corrosivity category of installation site to determine appropriate corrosivity class roof interface screw.

Determine Building Dimension

This document provides sufficient information for the PVezRack® SolarRoof system installation up to 20 meters building height (average roof height of structure above the ground, see the diagram below). If your building is more than 20 meters high, please contact Clenergy to obtain project specific engineering certificate to support your installation.

Building horizontal dimensions (b and d) are required to calculate the ratio of h/d to determine maximum interface spacing.

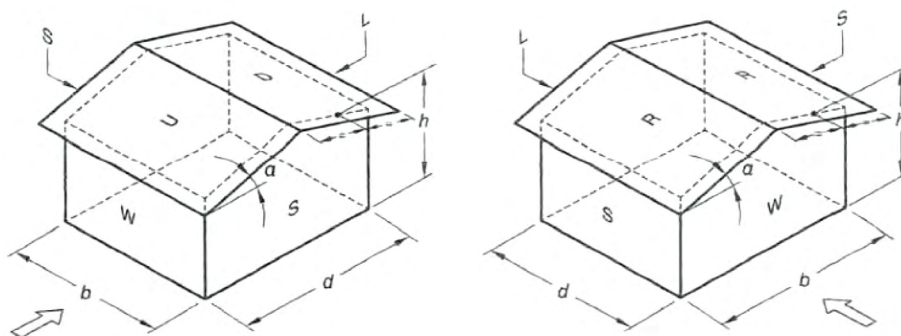

Parameters for Rectangular Enclosed Buildings

Determine Roof slope and Tilt Leg Angle

The PVezRack® SolarRoof Tilt Legs system is suitable for rails running perpendicular to the roof slope (including standard and reverse tilt), and slope up to 10° for rails running parallel to the roof slope.

Determine the Installation Area of Roof

There are 4 different roof zones for tilt leg installation: Internal Zone, Intermediate Zone, Edge Zone and Corner Zone. Please see diagrams and steps below to define area of each zone.

Step 1. Determine building height (h), width (b) and length (d) – see diagram above;

Step 2. The lowest value between "b x 0.2" and "d x 0.2" is "a" if h/b or h/d ≥ 0.2;

Step 3. "a" equates to 2h, if both h/b and h/d < 0.2,

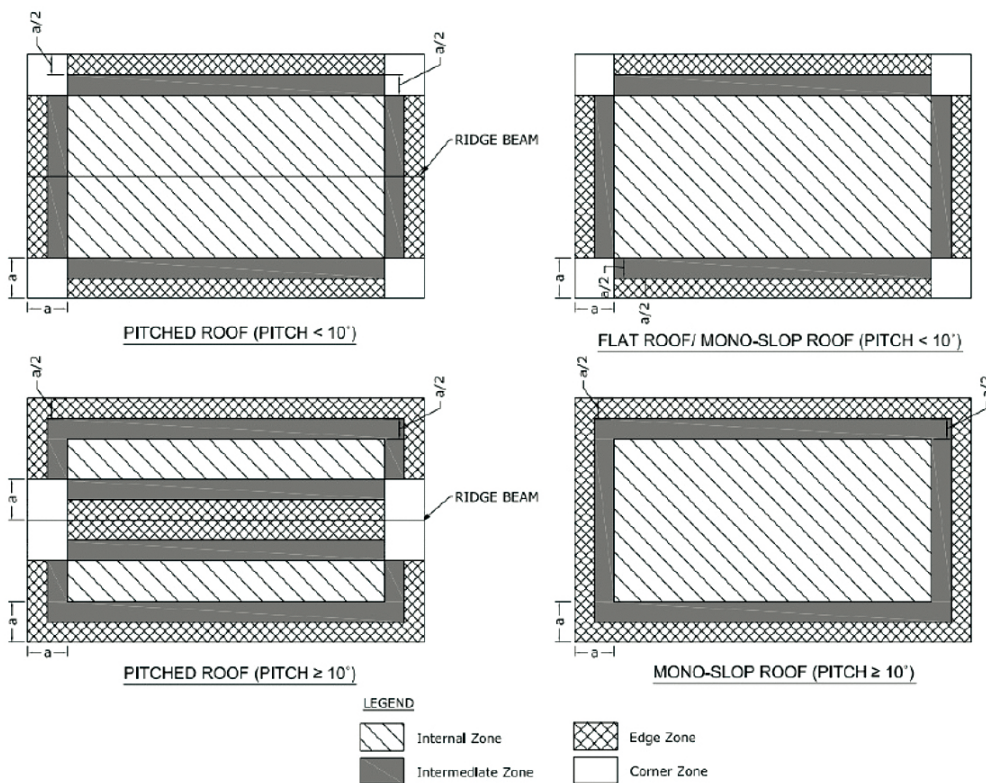

Roof Zones Definition

Verify Purlin Properties of Building

Please verify purlin properties of building, which could affect the interface spacing. Tilt legs spacing on in the certification letter is based on steel purlin G450 1.5 mm thick or 35 mm Timber F7 (Pine). For example, if the steel purlin is less than 1.5 mm thick, the corresponding reduction factor of interface spacing could be applied. Please refer to generic note 22 of engineering letter for details.

Determine Two Screws or One Screw Installations of Tilt Legs

There are options of using two screws or one screw for installations of adjustable and fixed tilt legs, depending on the project scenario, such as required interface spacing, purlin spacing, rib spacing of roof sheet and so on. Please find note 22 of engineering letter for details.

Determine the Maximum Rail Support Spacing

Please refer to the Certification Letter and Tilt Legs Spacing Table. If a project specific Certification Letter has been provided, please refer to the support spacing in this letter.

Verify Maximum Rail End Overhang

Rail end overhang should not be over 40% of the Tilt Legs spacing. For example, if the Tilt Legs spacing is 1500mm, the Rail end overhang can be up to 600mm only.

The application of Adjustable Tilt Legs

Following the tilt angle rules of Determine Roof Slope and Tilt Leg Angle on the north or south facing roof, the actual panel tilt angles using the adjustable tilt legs installed at the different purlin spacing could be applicable or not. Please see the table and side view diagrams below.

Application of Adjustable Tilt Legs																
Purlin spacing		1200 mm					1400 mm					1700 mm				
	Product	10°	15°	30°	45°	60°	10°	15°	30°	45°	60°	10°	15°	30°	45°	60°
1650 mm panel in portrait	ER-TL-10/15	✓ (1)	✓ (2)	×	×	×	✓ (6)	×	×	×	×	×	×	×	×	×
	ER-TL-15/30	×	×	×	×	×	×	✓ (8)	×	×	×	×	×	×	×	×
	ER-TL-30/60	×	×	✓ (3)	✓ (4)	×	×	×	✓ (10)	✓ (12)	×	×	×	✓ (14)	×	×
1960 mm panel in portrait	ER-TL-10/15	×	×	×	×	×	✓ (7)	×	×	×	×	×	×	×	×	×
	ER-TL-15/30	×	×	×	×	×	×	✓ (9)	×	×	×	×	×	×	×	×
	ER-TL-30/60	×	×	×	✓ (5)	×	×	×	✓ (11)	✓ (13)	×	×	×	✓ (15)	×	×

Note: ✓ indicates applicable; × indicates not applicable

The table above is based on:

- The panels are clamped within one quarter of panel length;
- Rear leg adjustable range: ER-TL-10/15: 260-375 mm; ER-TL-15/30: 390-635 mm; ER-TL-30/60: 675-1205 mm;
- If the info. is different from the table and diagram, it could have different results. Please contact the Clenergy to confirm its applicability.**

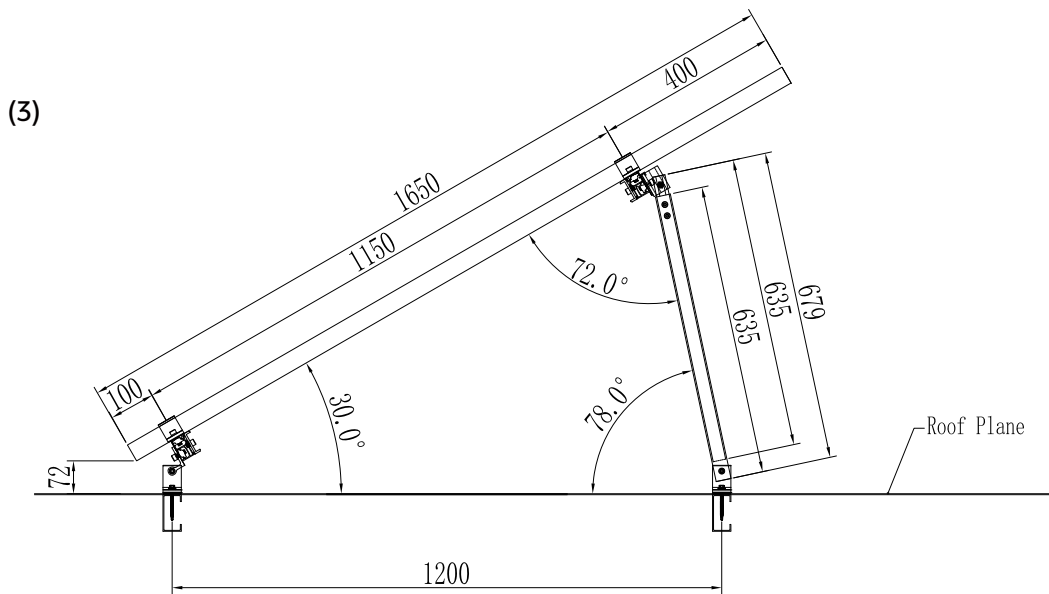
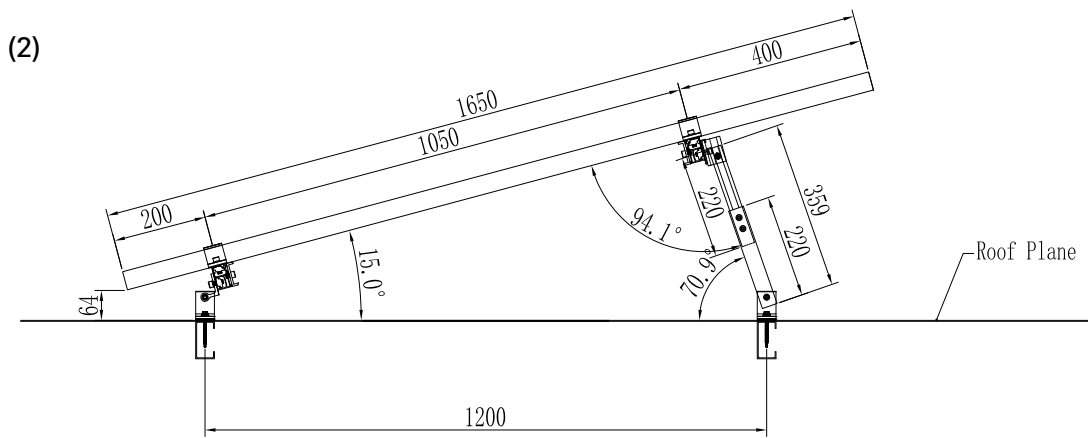
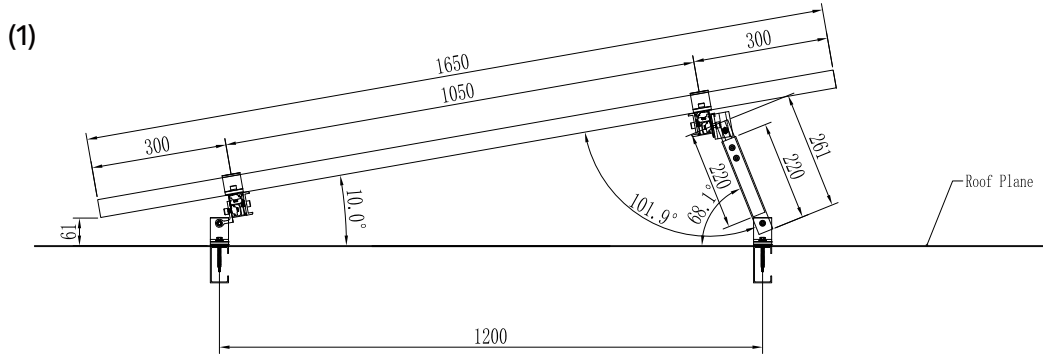

(4)

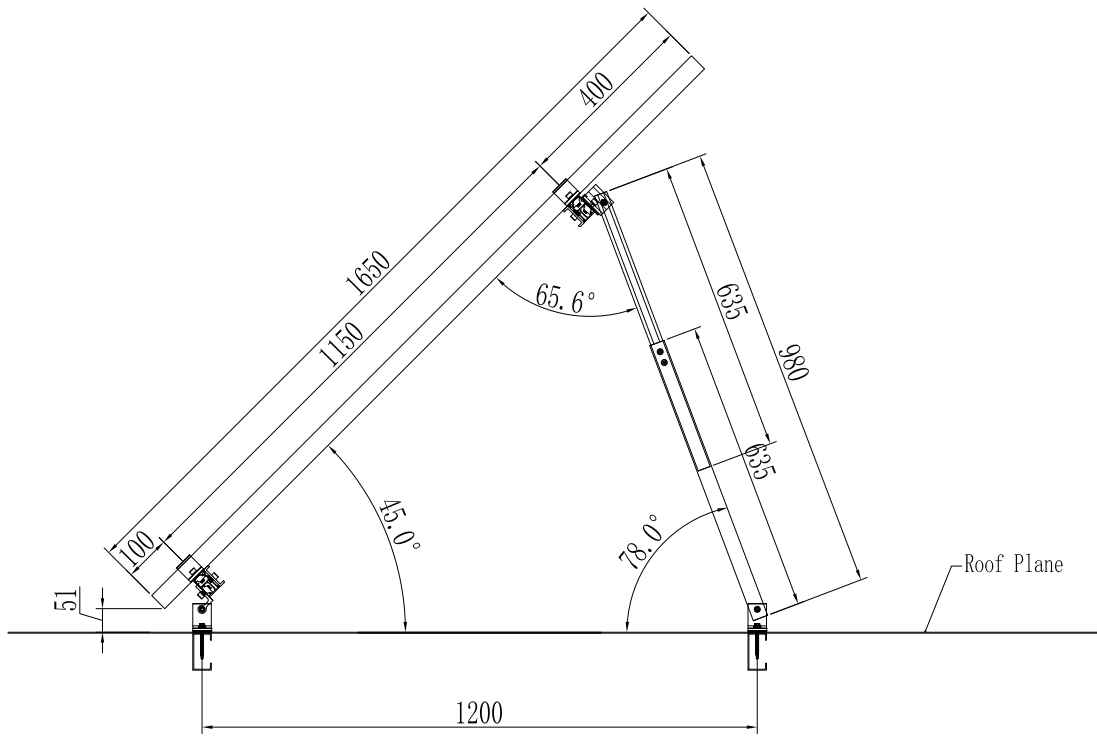

(5)

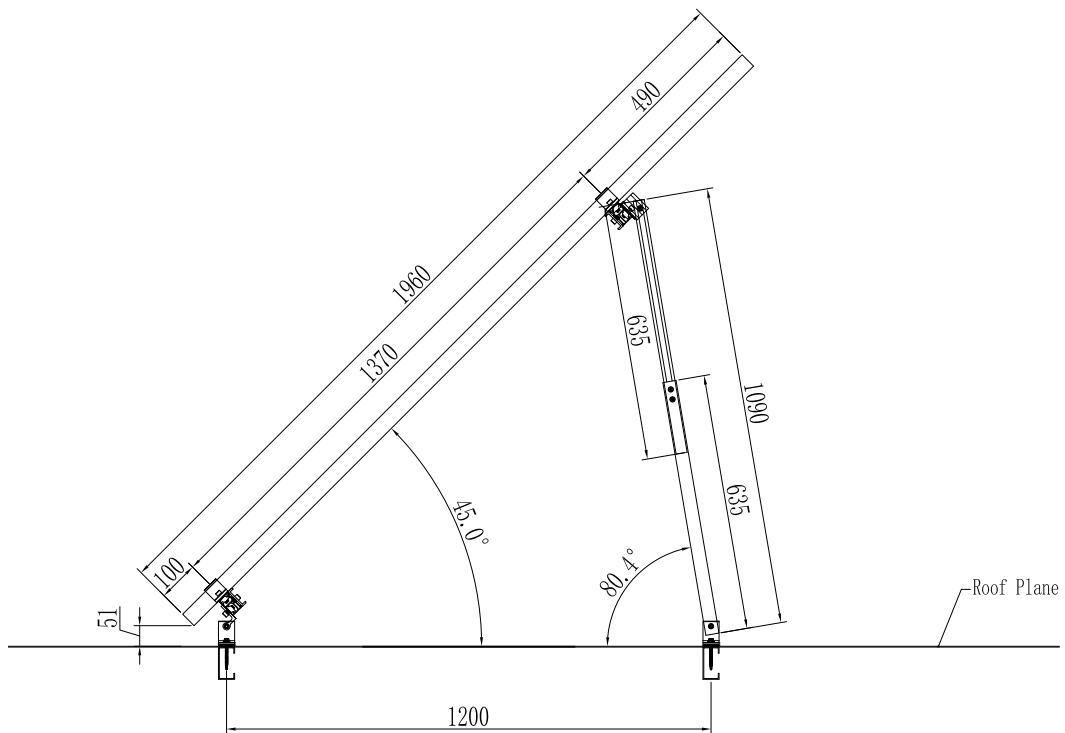

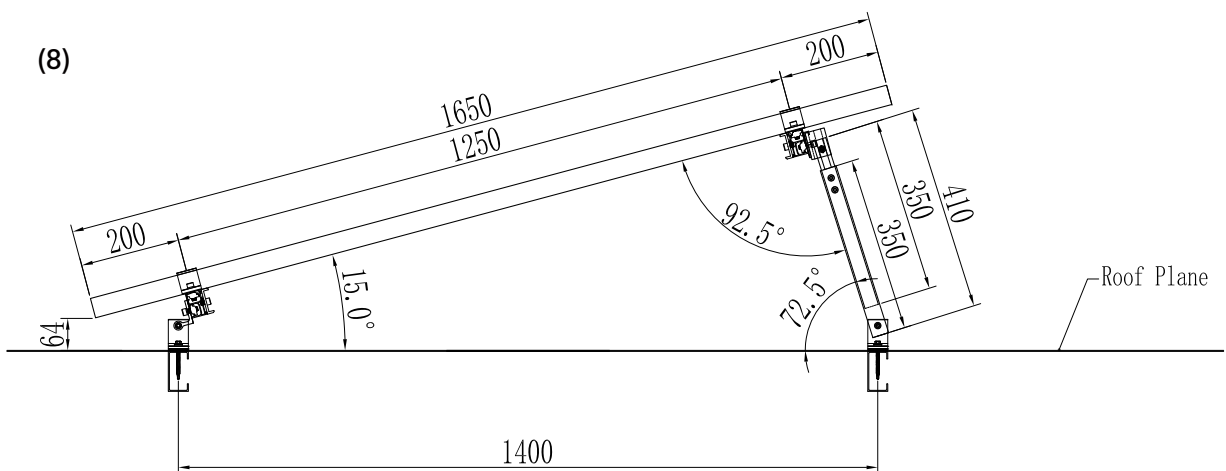
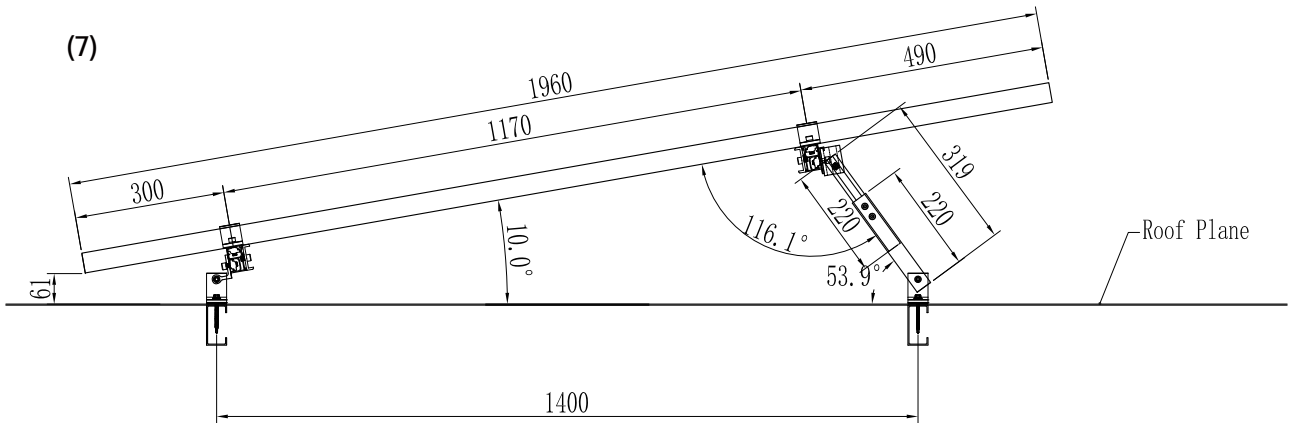
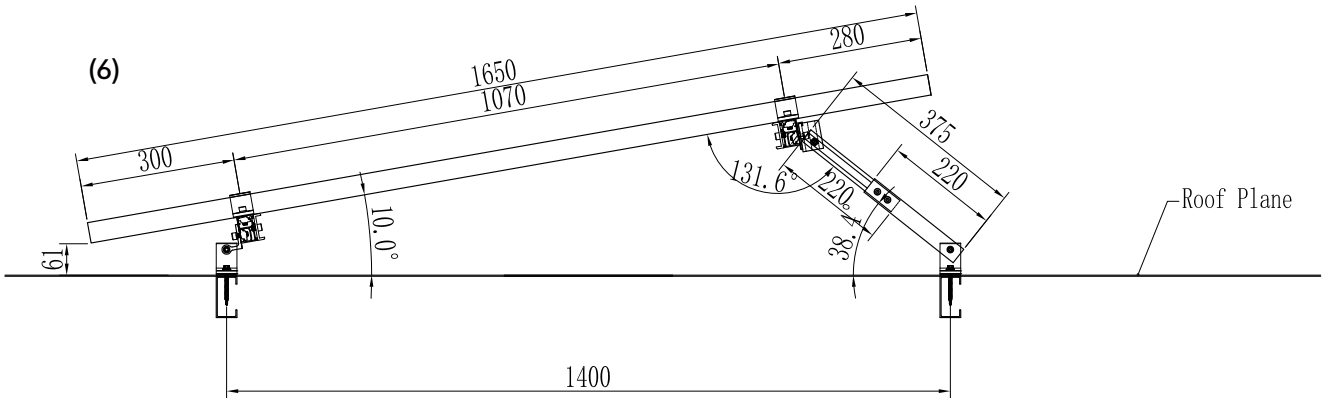

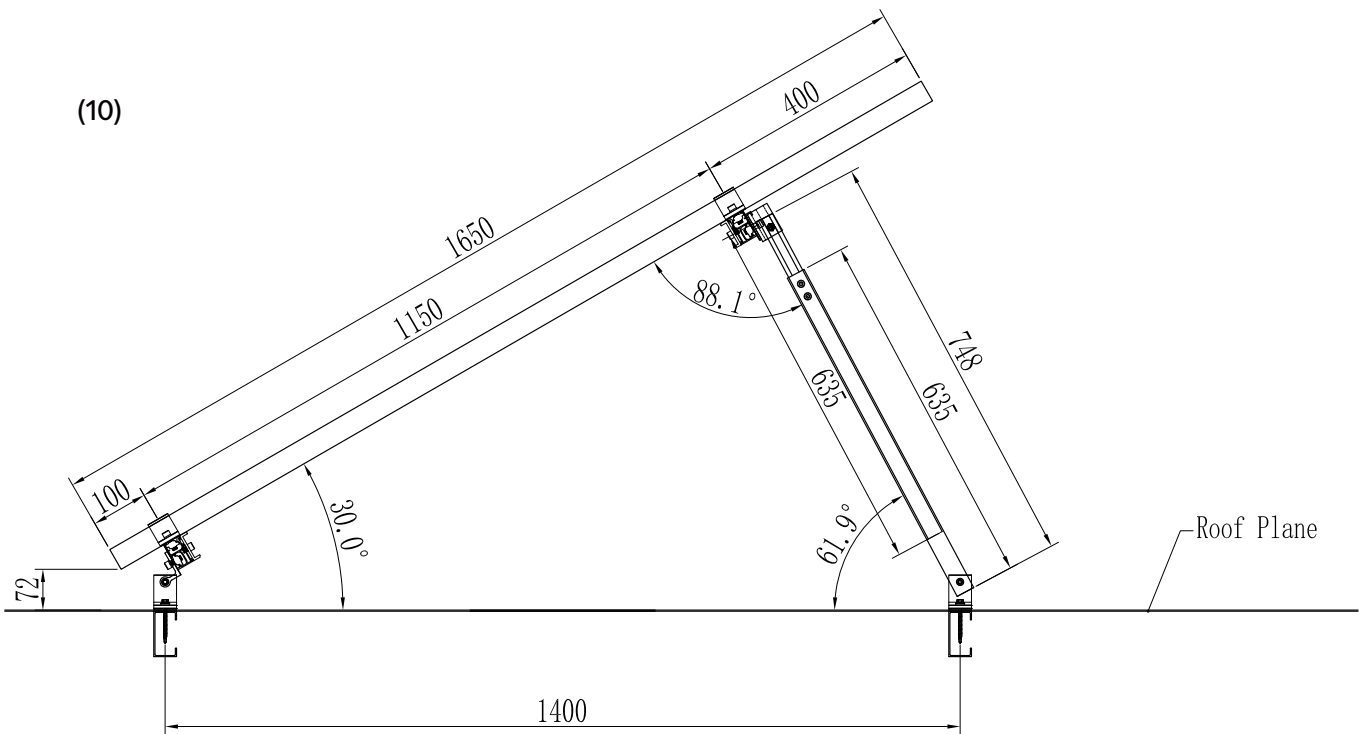
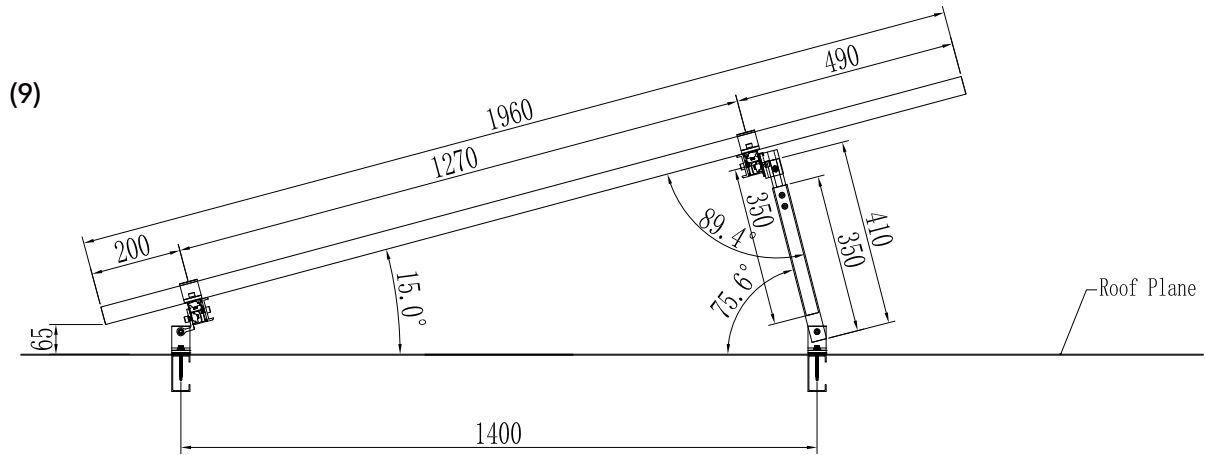

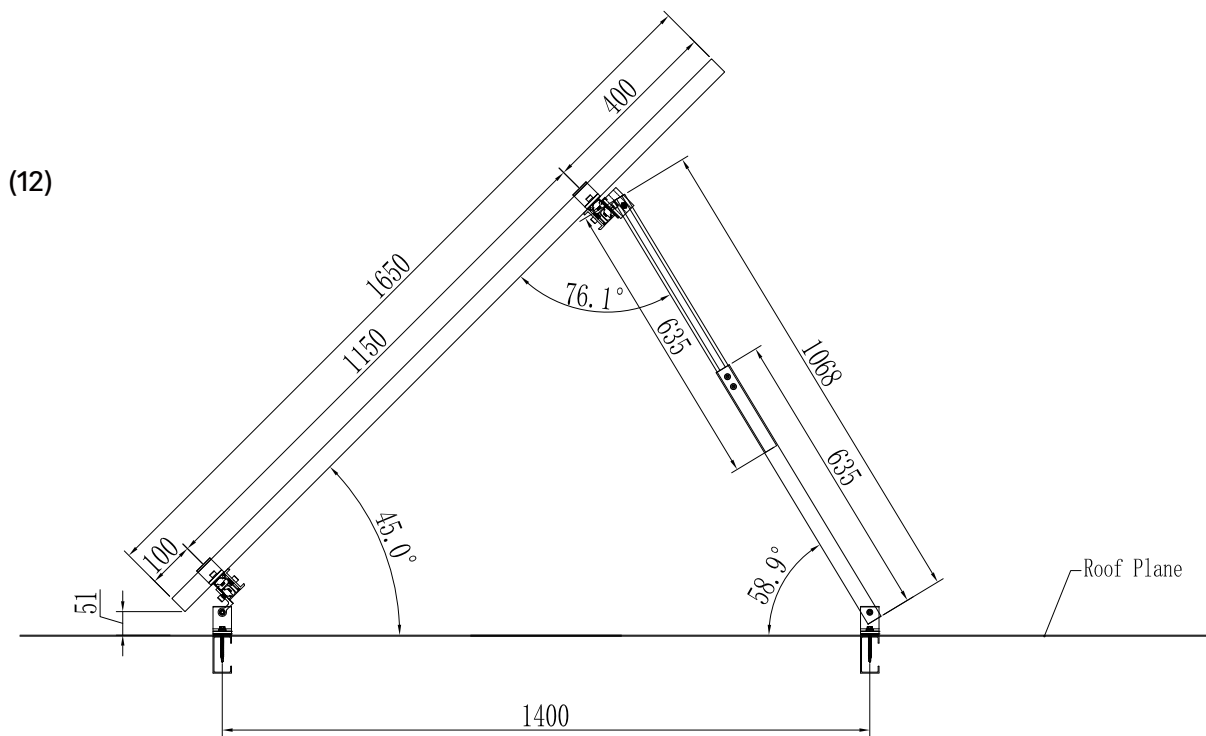
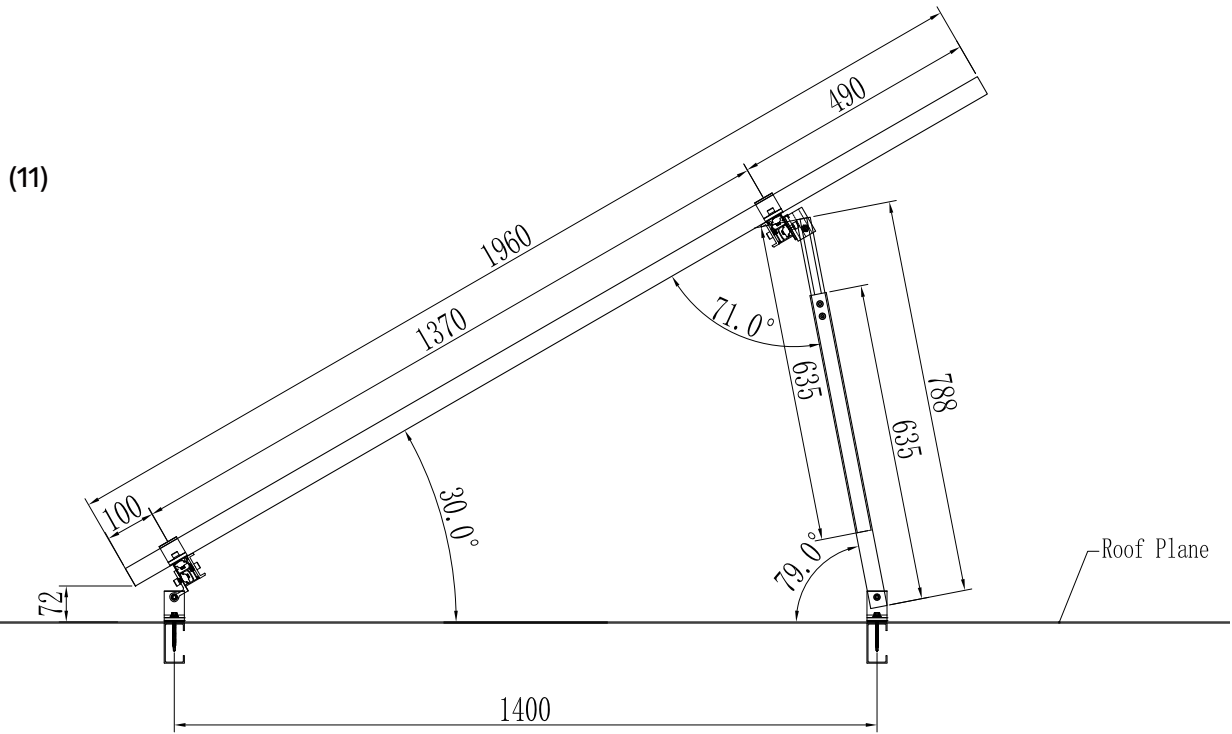

(13)

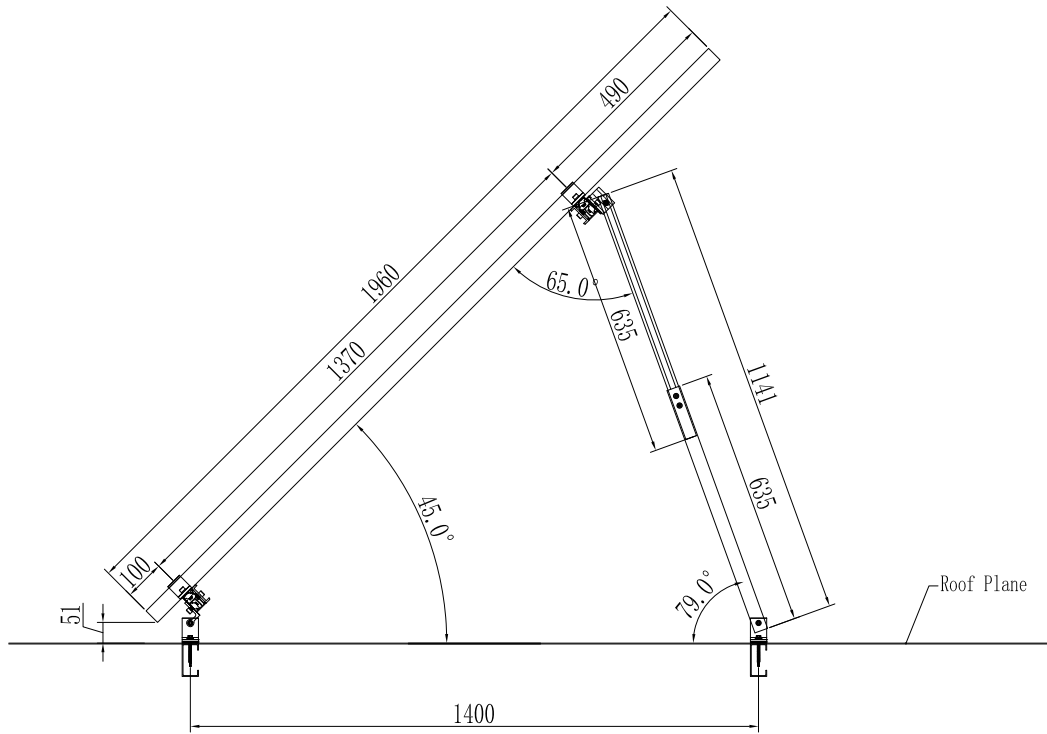



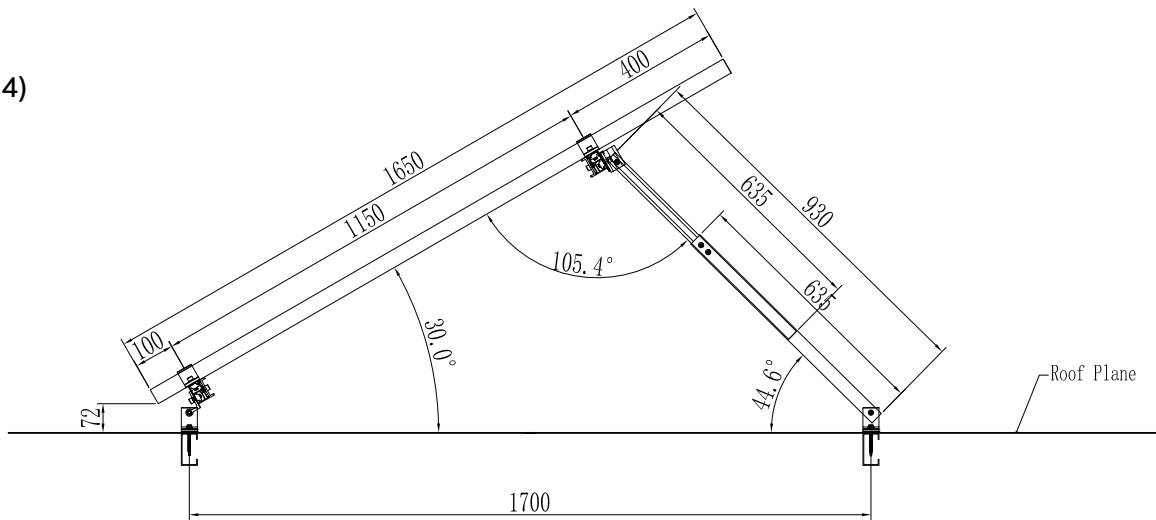

(14)











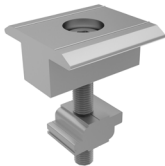

Tools and Components

Tools

				
<p>Screw Driver (maximum torque ≥ 34N·m)</p>	<p>Torque Spanner</p>	<p>Socket Wrench M8</p>	<p>5m Tape</p>	<p>String & Marker Pen</p>

Components

				
<p>ER-EC-ST End Clamp</p>	<p>ER-IC-ST Inter Clamp</p>	<p>C-U/30/46-G Akashi Clamp with grounding clip</p>	<p>C-U/30/46 Akashi Clamp</p>	<p>ER-TL-10/15 ER-TL-15/30 ER-TL-30/60 Adjustable Tilt legs, non-preassembly</p>
				
<p>ER-R-ELT Elite Rail</p>	<p>ER-SP-ECO Splice for ECO Rail</p>	<p>ER-SP-ELT Splice for Elite Rail</p>	<p>ER-CAP-ELT Cap for Elite Rail</p>	<p>ER-TL-10/15/PS ER-TL-15/30/PS Adjustable Tilt legs, preassembly</p>
				
<p>TL-10/15/L/PS TL-15/30/L/PS Adjustable Tilt Legs with L-feet, preassembly</p>	<p>ER-TL-5/PS ER-TL-10/PS Fixed Tilt Legs, preassembly</p>			

System Overview

Overview of PVezRack® SolarRoof

Tile Interface

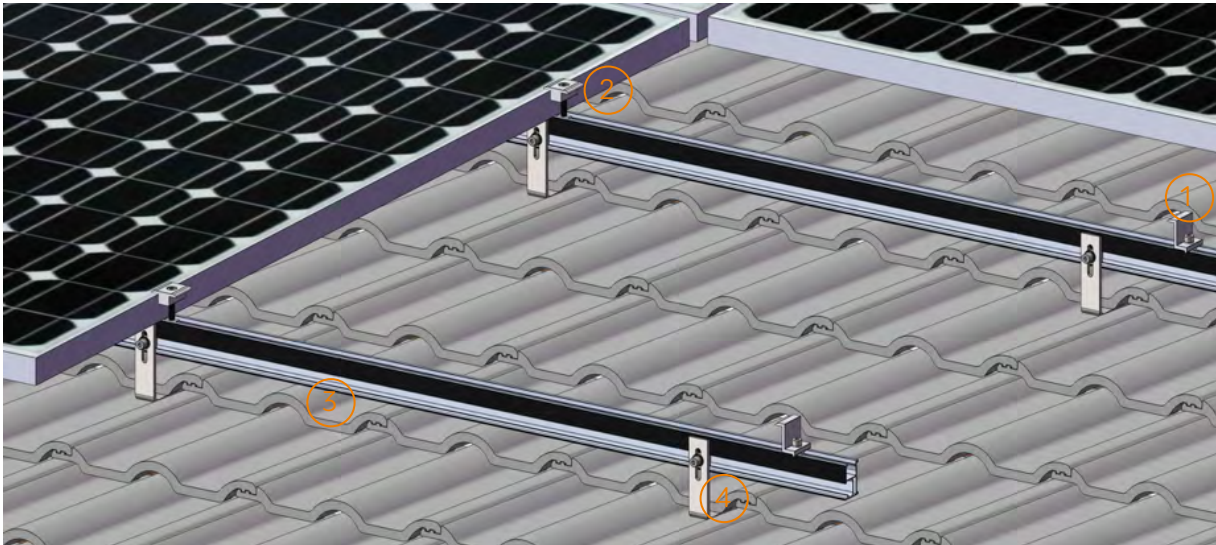

1. End Clamp 2. Inter Clamp 3. Elite Rail 4. Tile interface

Tin Interface



1. End Clamp 2. Inter Clamp 3. Elite Rail 4. Tin interface

Adjustable Tilt Legs

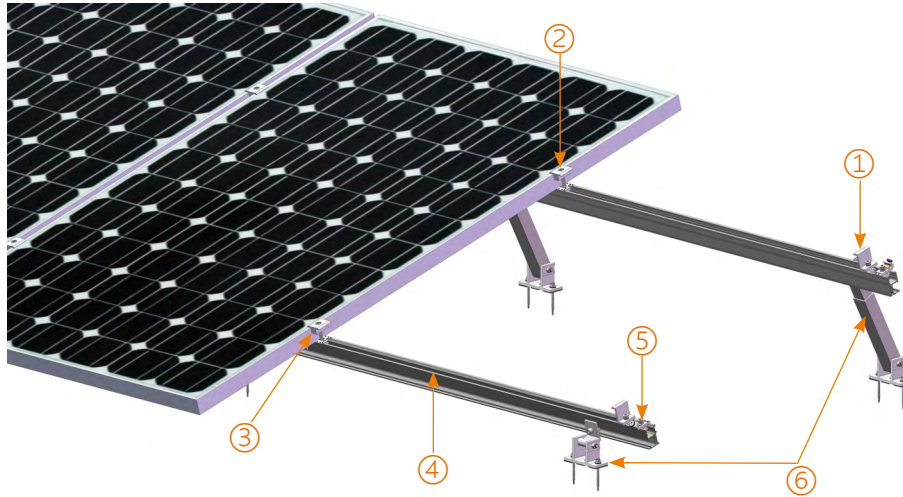

1. End Clamp 2. Inter Clamp 3. Grounding Clip 4. Elite Rail 5. Grounding Lug 6. Adjustable Tilt Legs

Adjustable Tilt Legs with L-feet

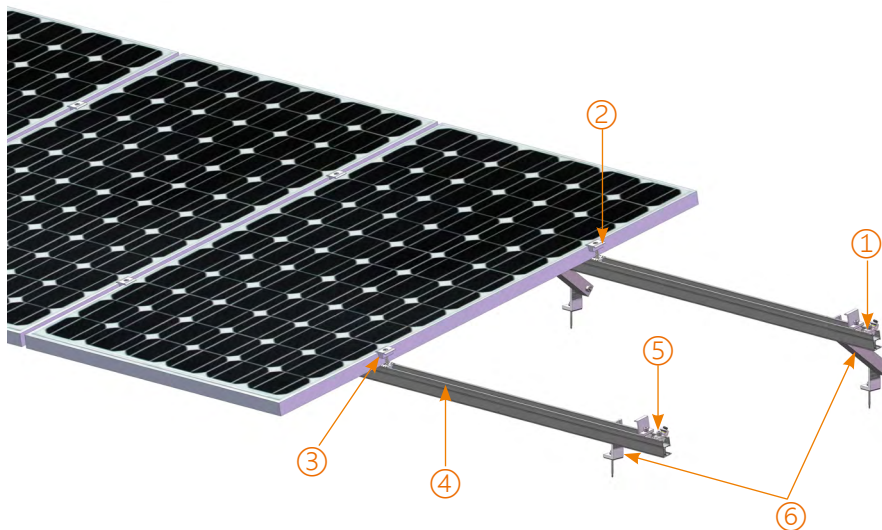

1. End Clamp 2. Inter Clamp 3. Grounding Clip 4. Elite Rail 5. Grounding Lug 6. Adjustable Tilt Legs with L-feet

Fixed Tilt Legs

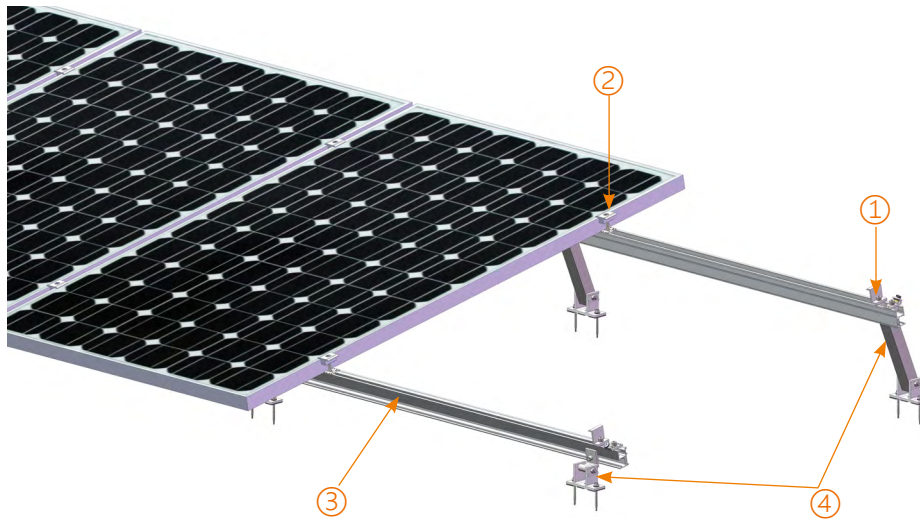

1. End Clamp 2. Inter Clamp 3. Elite Rail 4. Fixed Tilt Legs

Safe Torques

Please refer to safe torques defined in this guide as shown in the figure below. If power tools are required, Cleenergy recommends the use of low speed only. High speed and impact drivers increase the risk of bolt galling (deadlock). If deadlock occurs and you need to cut fasteners, please make sure that there is no load on the fastener before you cut it. Avoid damaging the anodized or galvanized surfaces.

1) Adjustable Tilt Legs

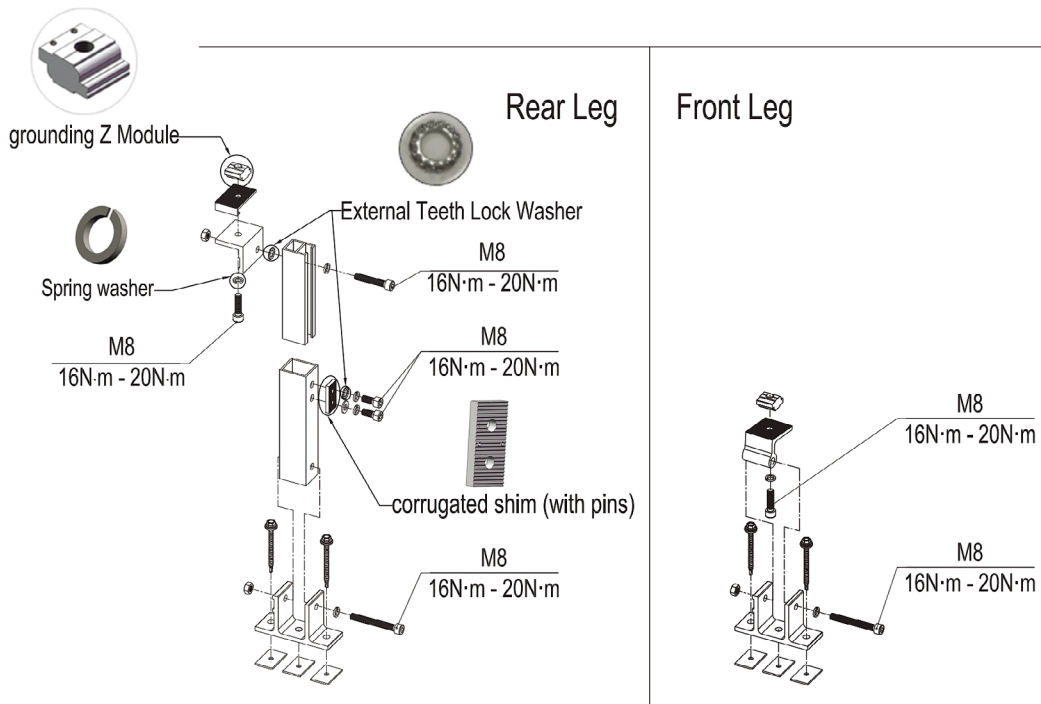

Note:

Grounding Z Module, External Teeth Lock Washers, Spring washer and corrugated shim (with pins) on the diagram above are to create the electrical continuity between rail and rear leg tubes.

2) Adjustable Tilt Legs with L-feet

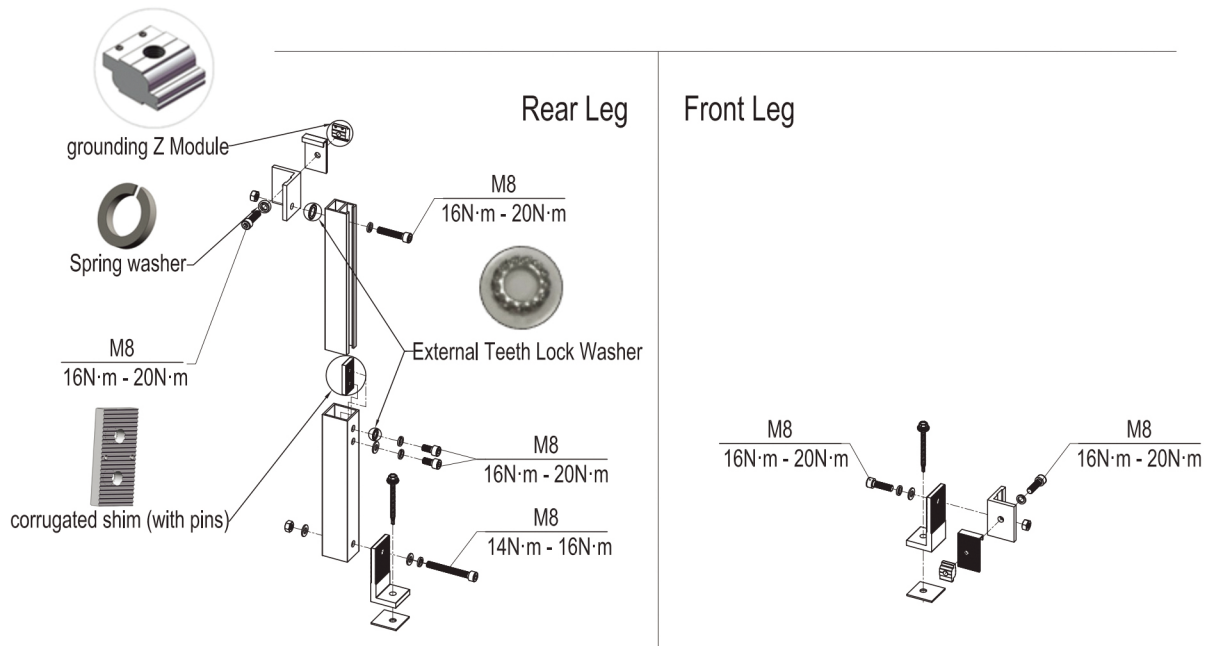

Note:

Grounding Z Module, External Teeth Lock Washers, Spring washer and corrugated shim (with pins) on the diagram above are to create the electrical continuity between rail and rear leg tubes.

3) Fixed Tilt Legs

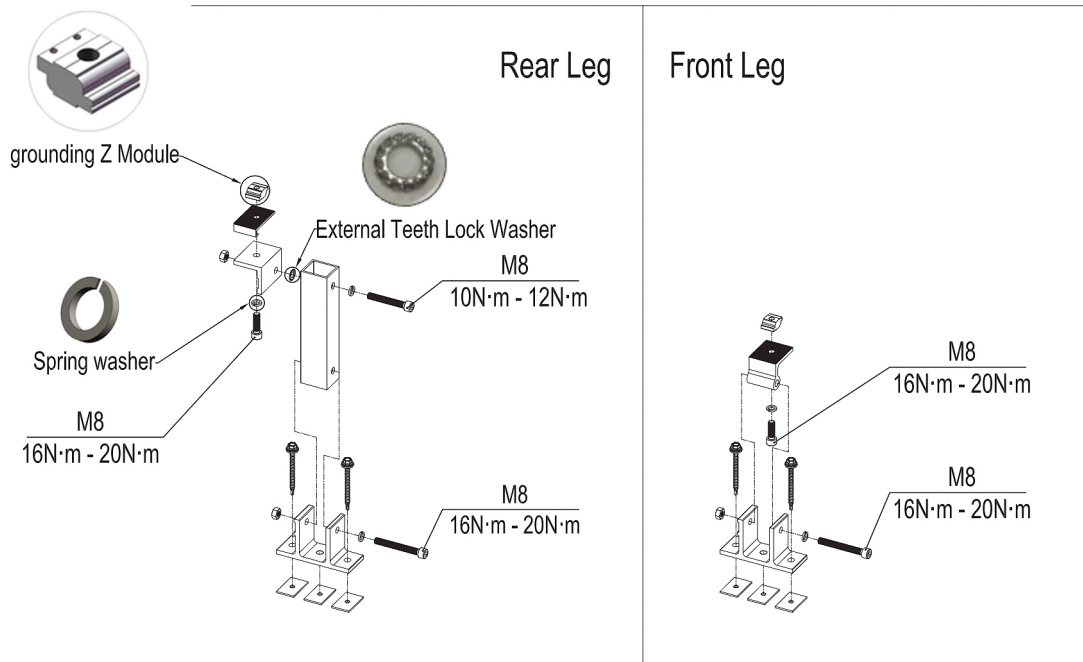

Note:

Grounding Z Module, External Teeth Lock Washer and Spring washer on the diagram above are to create the electrical continuity between rail and rear leg tubes.

Installation Instructions

Front & Rear Leg Installation

Front Leg Installation

According to the installation plan, determine the mounting position and direction of the front legs. Either two screws or single screw (Buildex 14-11 x 70 Hex Head Zips screw) is required depending on the installation spacing requirement. See two screws and single screw options in Figures 1 and 2. Tin foot front leg installation is in Figure 3.

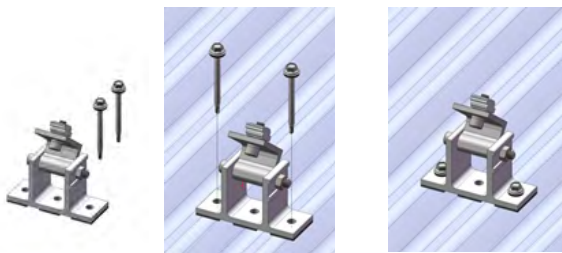

Figure 1
(Front Leg Installation with Two Screws)

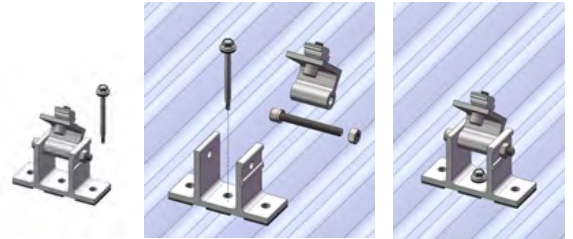

Figure 2
(Front Leg Installation with Single Screw)



Figure 3
(Tin Foot Front Leg Installation)

Notes:

1. Two screws shall be installed through two side holes of front leg (as shown in Figure 1);
2. Single screw shall be installed through central hole only of front leg (as shown in Figure 2).

Please follow Buildex screws installation guide below:

- Use a 3/8" Hex Socket.
- Use a mains powered or cordless screw driver with a drive speed of 3,000 RPM maximum.
- Fit the driver bit into the screw and place at the fastening position.
- Apply consistently firm pressure (end load) to the screw driver until the screw is fastened.
- Screws with bonded washers should be tightened only until the washer is gripped firmly enough to provide a watertight seal. The screws should be neither under tightened nor over tightened to lead to water penetration. Take particular care to ensure the screw is driven perpendicular to the interface to avoid deformation of the washer.

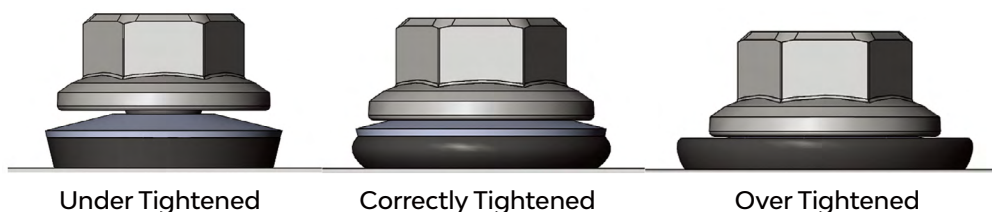

Rear Leg Installation

According to the installation plan, after confirming the length L of the Rear Leg, fasten two M8*12 bolts as shown in Figure 4.

Recommended torque for M8*12 bolts is 18~20 N·m

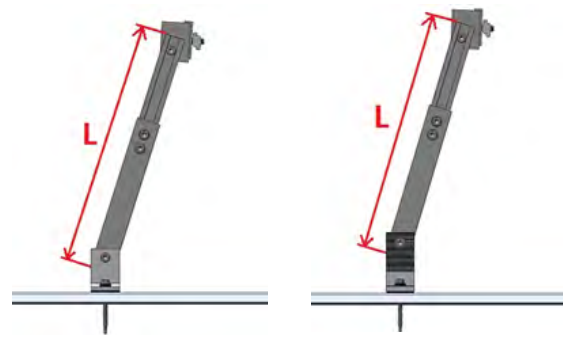

Figure 4

According to the installation plan, either two screws or single screw (Buildex 14-11 x 70 Hex Head Zips screw) is used to install rear leg. Using preassembly or non-preassembly rear legs will make installation steps a bit different as well. See the installation images in Figures 5-9.



Figure 5

(Non-preassembly Rear Leg Installation with Two Screws)

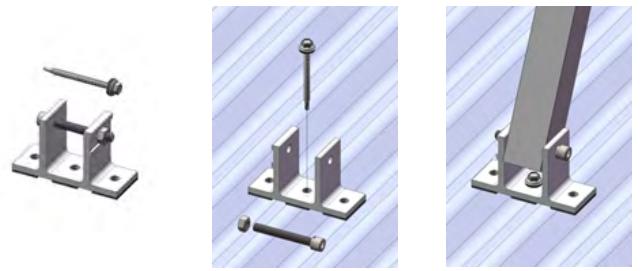

Figure 6

(Non-preassembly Rear Leg Installation with Single Screw)



Figure 7

(Preassembly Rear Leg Installation with Two Screws)

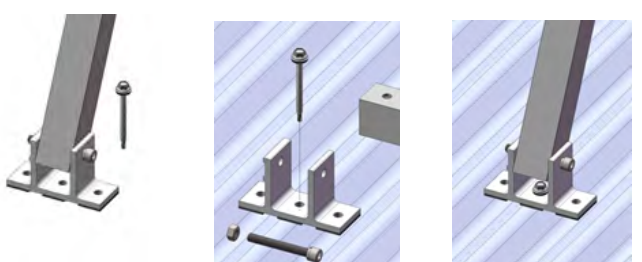

Figure 8

(Preassembly Rear Leg Installation with Single Screw)



Figure 9

(Tin Foot Rear Leg Installation)

Notes:

1. Two screws shall be installed through two side holes of rear leg (as shown in Figures 5 and 7);
2. Single screw shall be installed through central hole only of rear leg (as shown in Figures 6 and 8).

Install the remaining Front and Rear Legs in Figure 10.

NOTE:

WHEN USING TIN INTERFACES FOR INSTALLATION WORKS, SCREWS NOT EXPOSED TO FREQUENT RAIN SHOULD BE WASHED DOWN WITH FRESH WATER AT LEAST EVERY 6 MONTHS TO MEET THE WARRANTY CONDITIONS OF BUILDDEX SCREWS.

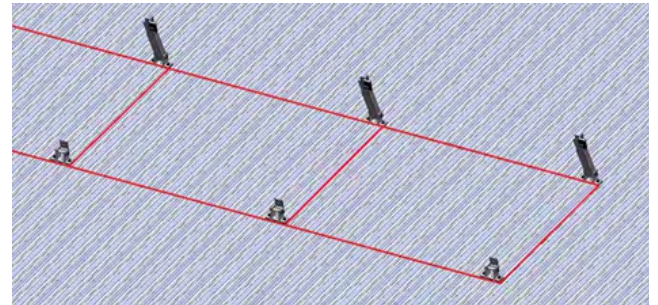
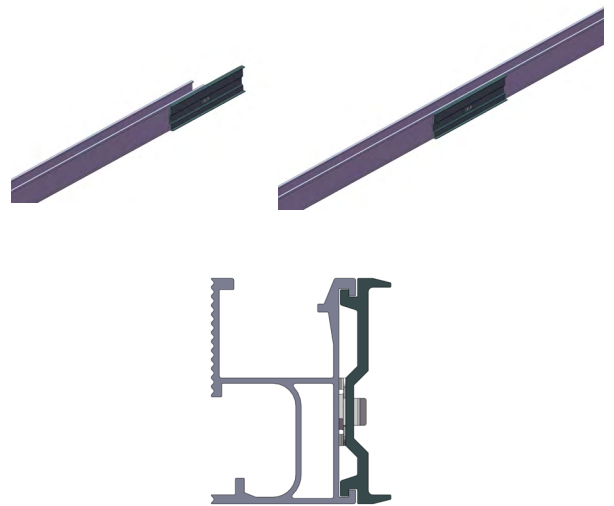

Figure 10

Rail Installation

- Option 1: Using Elite Rail Splice (ER-SP-ELT)

To connect several rails together, slide half of the splice into the rear side of the rail. The connection clip of splice can make self-locking with the rail without using any tool. Slide the next rail into the splice to complete two rails connection. The sharp teeth of connection clip of splice can provide the earthing continuity between two rails. This eliminates the need of using 2 grounding lugs.



Elite-rail installation with Elite rail splice

Figure 11

In case of requiring rails cutting to be joined by Elite rail splice, please make sure cutting as straight as possible to avoid splice clip teeth mistouching rails. It is because after installation it is just 3.4 mm from the rail end to the clip teeth as shown in the diagram.

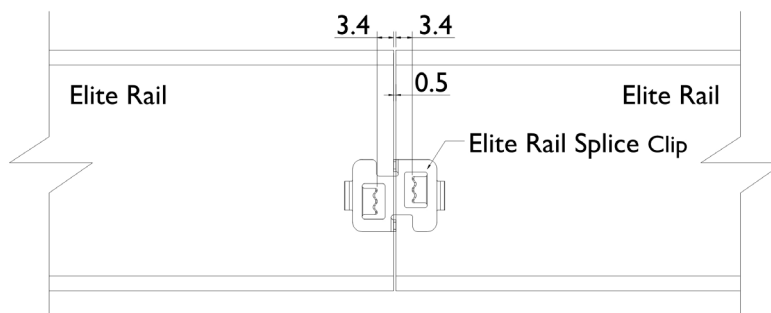

- Option 2: Using ECO Rail Splice (ER-SP-ECO)

ECO rail splice can be used for connecting Elite rails. To connect several rails together, slide half of the splice into the rear side of the rail. Fasten the first M8 bolt with torque of 2 ~ 4 Nm and slide the next rail into the splice and fasten the second M8 bolt with torque of 2 ~ 4 Nm. The low torque is not to impact the structural integrity of the system as the defined 2 ~ 4 N.m. Torque is sufficient to secure the required positioning of the splice for the design life of the system, and can provide the earthing continuity between two rails through the bolts and splice. This eliminates the need of using 2 grounding lugs.

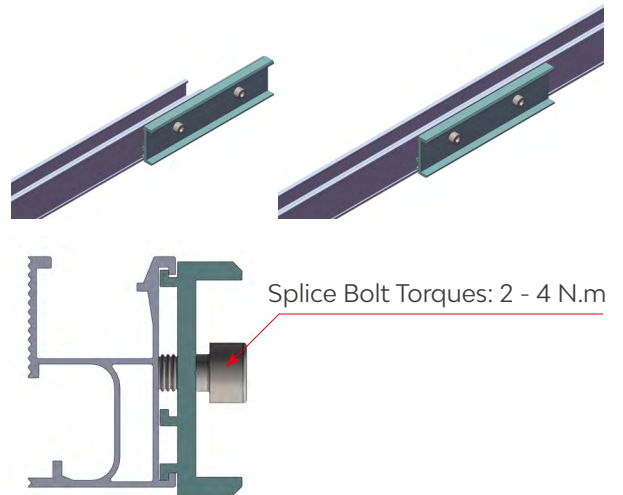

Elite-rail installation with ECO rail splice

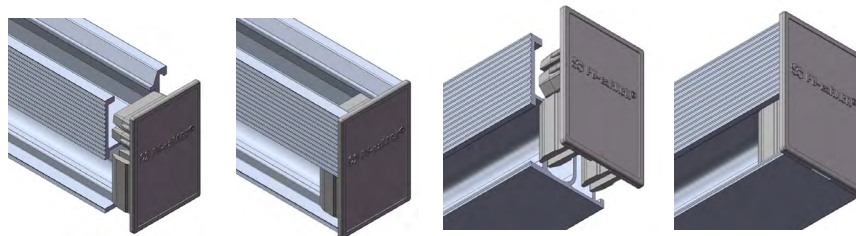

When installing Elite rail end cap, align the cap with the end of the Elite rail and firmly press and secure it in place.

After confirming the position of Rail, fasten the Front and Rear Leg, as shown in Figure 12, 13 and 14. Recommended torque for M8 bolts is 18~20 N·m



Figure 12

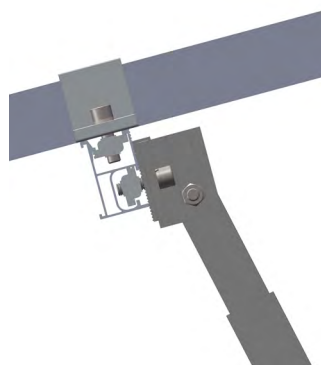

Figure 13



Figure 14

PV Module Installation

- 1) Please refer [PVezRack® Grounding System](#) for PV modules clamps and grounding lugs installations.
- 2) The installers must ensure panel clamps are installed flush mounted to the panel frame and apply correct torque value of clamp fastener as shown in section "Safe Torques (P18)".

Certification



PV Array Frame Engineering Certification

PV-ezRack SolarRoof Tilt Mount Penetrative Fixing System with ELITE Rail in New Zealand

For: Clenergy Australia
Suite 1, 10 Duerdin St
Clayton, VIC 3168

Job No.: 13924
Date: 24/01/2025





Document Control Record

A person using Gamcorp document or data accepts the risk of:

- a. Using the documents or data in electronic form without requesting and checking them for accuracy against the original hard copy version
- b. Using the documents or data for any purpose not agreed to in writing by Gamcorp.

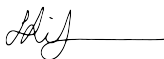
Document Control						
Report Title		General Certificate-Tilt Mount System-ELITE rails				
Document ID		13924-02-CER Rev2/JD	Job No.		13924	
File Path		G:\Shared drives\13924\13900 - 13999\13924\03 CERTIFICATION				
Client			Clenergy Australia		Client Contact	Tim Weng
Rev	Date	Revision Details	Prepared By	Author	Verifier	Approver
0	08/11/2023	Rev.1 of 13708-04	JD	JD	JG	JG
1	08/05/2024	ELITE rail splice added	JD	JD	BL	LvS
2	24/01/2025	Adding Zano Panel Clamps & New 5° Tilt Leg	HS	JD	AA	LvS
Current Revision			2			

Approval			
Author Signature		Approver Signature	
Name	Humam Sami	Name	L. Van Spaandonk
Title	Senior Structural Engineer	Title	Principal Engineer

COPYRIGHT: The concepts and information contained in this document are the property of Gamcorp Pty Ltd. Use or copying of this document in whole or in part without the written permission of Gamcorp constitutes an infringement of copyright.

LIMITATION: This report has been prepared on behalf of and for the exclusive use of Gamcorp Pty Ltd's Client, and is subject to and issued in connection with the provisions of the agreement between Gamcorp Pty Ltd and its Client. Gamcorp Pty Ltd accepts no liability or responsibility whatsoever for or in respect of any use of or reliance upon this report by any third party.

Our Ref:13924-2 Rev2/JD
24 January 2025

Clenergy Australia
Suite 1, 10 Duerdin St
Clayton, VIC 3168

PV Array Frame Engineering Certification

PV-ezRack SolarRoof Tilt Mount Penetrative Fixing System with ELITE Rail in New Zealand

Gamcorp Pty Ltd, being Structural Engineers within the meaning of Australian and New Zealand Building Regulations, have carried out a structural design check of Clenergy PV-ezRack SolarRoof Tilt Mount System installation with penetrative fixing within New Zealand. The design check has been based on the information and test reports provided by Clenergy Australia.

This certificate is **only valid** for Clenergy PV-ezRack SolarRoof. The roof structure or the building structure and PV panels shall be assessed separately and accordingly.

This certificate is **only valid** as a whole. Any information extracted from this certificate is not valid if standing alone.

We find the Installation of Clenergy PV-ezRack SolarRoof Flush Mount System for New Zealand use to be structurally sufficient based on the following conditions:

- Loading to:
 - AS/NZS1170.0:2002 – Structural design actions, Part 0: General principles;
 - AS/NZS1170.1:2002 (R2016) – Structural design actions, Part 1: Permanent, imposed and other actions;
 - AS/NZ1170.2:2021 Wind actions;
 - AS/NZ1170.3:2003 Snow and ice actions;
 - NZS 4219:2009 Seismic performance of engineering systems in buildings.
- Corrosion calculation for **corrosion zone C1 – C5** refer to
 - ISO 9223:2012-Corrosion of metals and alloys - Corrosivity of atmospheres - Classification, determination and estimation
 - ISO 9224:2012-Corrosion of metals and alloys - Corrosivity of atmospheres - Guiding values for the corrosivity categories
 - ISO 9226:2012-Corrosion of metals and alloys - Corrosivity of atmospheres - Determination of corrosion rate of standard specimens for the evaluation of corrosivity

- Importance level **2**; Design life **25 years**
Wind average recurrence interval of **250 years**
Snow average recurrence interval of **50 years**
- Wind region **NZ1 to NZ4**
- Snow region
 - Sub-alpines (Regions N1 to N5)
 - Alpine regions are excluded for snow assessment
- Wind terrain category **2 & 3**
- Maximum building height **20m**
- The assessed base PV panel dimensions are **2000mm x 1000mm**
- Tilt angle is measured to the roof surface
- Maximum wind pressure is limited to **5kPa**
- Maximum Weight of the PV panels to be **15 kg/m²**
- Rails to be **ELITE Rail**
- The base interface spacing is according to fixing into minimum **1.5BMT** steel or minimum **35mm embedment** into JD4 seasoned timber (**2 screws** per each interface)
- The interface spacing chosen for installation must be the **minimum value** in the attached table, which are determined by earthquake, snow and wind loads
- Each PV panel to be installed using **2 rails** minimum in all circumstances
- No PV panel to be installed within **2xs** from edges and ridge. "**s**" is the maximum gap between the underside of the panel and the roof surface when installed on the roof (**50mm ≤ s ≤ 300mm**)
- Installation of PV panels to be done in accordance with the PV panels installation manual
- The certification **excludes** assessment of roof structure and PV panels

Refer to attached summary table for interface spacing (Unit: mm)

NOTES:

- **The recommended spacing nominated in this certification is based on the capacity of the array frame and the fixing of array frames to the roof, not the roof structure and PV panels. It is the responsibility of the installer to adopt the most critical spacing.**
- **The spacing shown in the interface tables shall be adjusted based on the assessment and requirement of the roof structures.**
- **If any of the above conditions cannot be met, the structural engineer must be notified immediately.**

Construction is to be carried out strictly in accordance with the manufacturer's instructions. This work was designed by **Jiewen Deng** in accordance with the provisions of relevant Building Regulations and in accordance with sound, widely accepted engineering principles. This certificate is only valid till 24/01/2027. Gamcorp should be contacted for future validation. Contact Gamcorp for customised system or if the site conditions are not covered by this assessment.

Yours faithfully,
Gamcorp Pty Ltd



L. Van Spaandonk

Principal Engineer

FIEAust CPEng NER 5038980

APEC Engineer IntPE(Aus) CMEngNZ 2003796

NT Registration: 244137ES

QLD Registration: 18703

VIC Registration: PE0001956

TAS Registration: CC7366

Gamcorp Pty Ltd A.C.N 665 643 658 A.B.N 86 665 643 658
www.gamcorp.com.au melbourne@gamcorp.com.au
37 Butler St, Richmond VIC 3121
Tel: 03 9543 2211

Structural Design Documentation

Tilt Array Frame System Spacing Table

According to AS/NZS 1170.2-2021

with ELITE Rails – Tin Roof (Pierced Fix Roof)

within New Zealand

Terrain Category 2 & 3

For: **CLENERGY AUSTRALIA**
1/10 Duerdin St
Clayton, VIC 3168

Job Number: 13924 (ELITE Rails & Tilt)
Revision: 2
Date: 23 January 2025



COPYRIGHT: The concepts and information contained in this document are the property of Gamcorp Pty Ltd. Use or copying of this document in whole or in part without the written permission of Gamcorp constitutes an infringement of copyright.

LIMITATION: This report has been prepared on behalf of and for the exclusive use of Gamcorp Pty Ltd's Client, and is subject to and issued in connection with the provisions of the agreement between Gamcorp Pty Ltd and its Client. Gamcorp Pty Ltd accepts no liability or responsibility whatsoever for or in respect of any use of or reliance upon this report by any third party.

Gamcorp Pty Ltd A.C.N 665 643 658 A.B.N 86 665 643 658
www.gamcorp.com.au melbourne@gamcorp.com.au
37 Butler St, Richmond VIC 3121
Tel: 03 9543 2211

Job No: 13924
Client: CLENERGY AUSTRALIA
Project: Tilt Array Frame System Spacing Table
with ELITE Rails – Tin Roof (Pierced Fix Roof)
Address: within New Zealand
Wind Terrain Category: Terrain Category 2 & 3

Australian/New Zealand Standards

AS/NZS 1170.0:2002	Structural design actions Part 0: General principles
AS/NZS 1170.1:2002 (R2016)	Structural design actions Part 1: Permanent, imposed and other actions
AS/NZS 1170.2:2021	Structural design actions Part 2: Wind actions
AS/NZS 1170.3:2003	Structural design actions Part 3: Snow and ice actions
AS/NZS 1664.1:1997	Aluminium structures Part 1: Limit state design
AS/NZS 4600:2018	Cold-formed steel structures
AS 4100:2020	Steel structures
NZS 4219:2009	Seismic performance of engineering systems in buildings

Designed: JD
Checked: JG
Date: Jan-25

Client: **CLENERGY AUSTRALIA**
 Project: **Tilt Array Frame System Spacing Table with ELITE Rails – Tin Roof (Pierced Fix Roof) within New Zealand**
 Address: **within New Zealand**

Job: **13924**
 Date: **Jan-25**
 Designed: **JD**
 Checked: **JG**

Tilt Array Frame System Spacing Table for Tin Roof (mm)

Type of Rail: ELITE Rails
 Type of Interface: Tilt Leg
 Solar Panel Dimension: 2mx1m
 Terrain category: 2

Tilt angle to roof surface (α), $\alpha \leq 15^\circ$

Wind Region	Building Height – h (m)															
	h ≤ 5				5 < h ≤ 10				10 < h ≤ 15				15 < h ≤ 20			
	Corner	Edge	Intermediate	Internal	Corner	Edge	Intermediate	Internal	Corner	Edge	Intermediate	Internal	Corner	Edge	Intermediate	Internal
NZ1&NZ2	545	830	1125	1510	--	680	920	1400	--	615	830	1280	--	580	780	1205
NZ1&NZ2 with M _{lee} of 1.35	--	--	595	910	--	--	490	750	--	--	--	675	--	--	--	635
NZ1&NZ2 with M _{lee} of 1.20	--	565	765	1175	--	465	625	960	--	--	565	865	--	--	535	815
NZ3	--	610	820	1265	--	500	675	1035	--	--	605	930	--	--	575	875
NZ4	--	660	895	1350	--	540	730	1125	--	490	660	1015	--	465	625	955

Tilt angle to roof surface (α), $15^\circ < \alpha \leq 25^\circ$

Wind Region	Building Height – h (m)															
	h ≤ 5				5 < h ≤ 10				10 < h ≤ 15				15 < h ≤ 20			
	Corner	Edge	Intermediate	Internal	Corner	Edge	Intermediate	Internal	Corner	Edge	Intermediate	Internal	Corner	Edge	Intermediate	Internal
NZ1&NZ2	--	585	790	1215	--	480	645	990	--	--	585	895	--	--	550	840
NZ1&NZ2 with M _{lee} of 1.35	--	--	--	640	--	--	--	525	--	--	--	475	--	--	--	--
NZ1&NZ2 with M _{lee} of 1.20	--	--	540	825	--	--	--	675	--	--	--	610	--	--	--	575
NZ3	--	--	580	885	--	--	475	725	--	--	--	655	--	--	--	615
NZ4	--	465	630	960	--	--	515	790	--	--	465	710	--	--	--	670

Tilt angle to roof surface (α), $25^\circ < \alpha \leq 60^\circ$

Wind Region	Building Height – h (m)															
	h ≤ 5				5 < h ≤ 10				10 < h ≤ 15				15 < h ≤ 20			
	Corner	Edge	Intermediate	Internal	Corner	Edge	Intermediate	Internal	Corner	Edge	Intermediate	Internal	Corner	Edge	Intermediate	Internal
NZ1&NZ2	--	--	580	885	--	--	475	725	--	--	--	655	--	--	--	620
NZ1&NZ2 with M _{lee} of 1.35	--	--	--	470	--	--	--	--	--	--	--	--	--	--	--	--
NZ1&NZ2 with M _{lee} of 1.20	--	--	--	605	--	--	--	495	--	--	--	--	--	--	--	--
NZ3	--	--	--	650	--	--	--	535	--	--	--	480	--	--	--	--
NZ4	--	--	460	705	--	--	--	580	--	--	--	520	--	--	--	495

Client: **CLENERGY AUSTRALIA**
 Project: **Tilt Array Frame System Spacing Table with ELITE Rails – Tin Roof (Pierced Fix Roof) within New Zealand**
 Address: **within New Zealand**

Job: **13924**
 Date: **Jan-25**
 Designed: **JD**
 Checked: **JG**

Tilt Array Frame System Spacing Table for Tin Roof (mm)

Type of Rail: ELITE Rails
 Type of Interface: Tilt Leg
 Solar Panel Dimension: 2mx1m
 Terrain category: 3

Tilt angle to roof surface (α), $\alpha \leq 15^\circ$

Wind Region	Building Height – h (m)															
	h≤5				5<h≤10				10<h≤15				15<h≤20			
	Corner	Edge	Intermediate	Internal	Corner	Edge	Intermediate	Internal	Corner	Edge	Intermediate	Internal	Corner	Edge	Intermediate	Internal
NZ1&NZ2	655	1010	1375	1620	655	1010	1375	1620	565	865	1175	1535	505	770	1045	1470
NZ1&NZ2 with M_{lee} of 1.35	--	535	725	1110	--	535	725	1110	--	465	625	955	--	--	560	855
NZ1&NZ2 with M_{lee} of 1.20	--	685	930	1405	--	685	930	1405	--	590	800	1230	--	530	715	1095
NZ3	485	735	1000	1425	485	735	1000	1425	--	635	860	1330	--	570	770	1185
NZ4	525	800	1085	1450	525	800	1085	1450	--	690	935	1375	--	615	835	1285

Tilt angle to roof surface (α), $15^\circ < \alpha \leq 25^\circ$

Wind Region	Building Height – h (m)															
	h≤5				5<h≤10				10<h≤15				15<h≤20			
	Corner	Edge	Intermediate	Internal	Corner	Edge	Intermediate	Internal	Corner	Edge	Intermediate	Internal	Corner	Edge	Intermediate	Internal
NZ1&NZ2	465	705	960	1420	465	705	960	1420	--	610	825	1270	--	545	735	1130
NZ1&NZ2 with M_{lee} of 1.35	--	--	510	780	--	--	510	780	--	--	--	670	--	--	--	600
NZ1&NZ2 with M_{lee} of 1.20	--	485	650	1000	--	485	650	1000	--	--	565	860	--	--	505	770
NZ3	--	520	700	1075	--	520	700	1075	--	--	605	925	--	--	540	825
NZ4	--	565	760	1170	--	565	760	1170	--	490	660	1010	--	--	585	895

Tilt angle to roof surface (α), $25^\circ < \alpha \leq 60^\circ$

Wind Region	Building Height – h (m)															
	h≤5				5<h≤10				10<h≤15				15<h≤20			
	Corner	Edge	Intermediate	Internal	Corner	Edge	Intermediate	Internal	Corner	Edge	Intermediate	Internal	Corner	Edge	Intermediate	Internal
NZ1&NZ2	--	520	700	1080	--	520	700	1080	--	--	605	925	--	--	540	825
NZ1&NZ2 with M_{lee} of 1.35	--	--	--	570	--	--	--	570	--	--	--	495	--	--	--	--
NZ1&NZ2 with M_{lee} of 1.20	--	--	480	735	--	--	480	735	--	--	--	630	--	--	--	565
NZ3	--	--	515	790	--	--	515	790	--	--	--	680	--	--	--	605
NZ4	--	--	560	855	--	--	560	855	--	--	485	740	--	--	--	660

Client: **CLENERGY AUSTRALIA**
 Project: **Tilt Array Frame System Spacing Table with ELITE Rails – Tin Roof (Pierced Fix Roof)**
 Address: **within New Zealand**

Job: **13924**
 Date: **Jan-25**
 Designed: **JD**
 Checked: **JG**

General Notes

Note 1 Following components are satisfied to use according to AS/NZS 1170.2:2021

Components	Part Number	Description
ELITE Rail	ER-R-ELT	As per drawing or test report provided by client
ECO Rail Splice	ER-SP-ECO, ER-SP-ECO/BA	
Elite Rail Splice	ER-SP-ELT, ER-SP-ELT/BA	
Standard Inter Clamp	ER-IC-ST, ER-IC-ST/BA	
Standard End Clamp	ER-EC-ST, ER-EC-ST/BA	
Zano Inter Clamp	ER-IC-28/42/L50/G/BA	
Zano End Clamp	ER-EC-28/42/L50/BA	
Akashi Clamp	C-U/30/46, C-U/30/46/BA	
Akashi Clamp with Grounding Clip	C-U/30/46-G, C-U/30/46-G/BA	
Adjustable Tilt Leg	ER-TL-10/15, ER-TL-15/30, ER-TL-30/60	
Adjustable Tilt Leg, pre-assembled	ER-TL-10/15/PS, ER-TL-15/30/PS	
Adjustable Tilt Leg with L-feet, pre-assembled	TL-10/15/L/PS, TL-15/30/L/PS	
Fixed Tilt Leg, pre-assembled	ER-TL-5/PS, ER-TL-10/PS	
Fixed Tilt Leg, 5° Tilt	ER-TL-5-L-C5	

Note 2 Tin roof interface spacing calculated based on 1.5mm steel purlin G450 or 35mm screw embedment into F7 (Pine) timber (JD4 seasoned timber). (2 screws per each interface)

Recommended screws

Metal Purlins/Battens	Fasteners to use
0.42mm to 0.75mm (G550)	14g-10 TPI Tek screws or approved equivalent
1.2mm to 2.4mm (G450)	14g-10 TPI Tek screws or approved equivalent
Timber Purlins/Battens/Rafters	Fasteners to use
Softwood F7 (Pine) (JD4 seasoned timber)	14g-10 TPI T17 screws or approved equivalent
Hardwood F17 (JD3 seasoned timber)	14g-10 TPI T17 screws or approved equivalent

Note 3 Maximum uplift wind pressure is limited to 4.7kPa.

Note 4 Deflection is limited to Minimum of L/120 and 15mm.

Note 5 Tilt angle is measured from roof surface.

Note 6 "-" states NOT SUITABLE FOR INSTALLATION.

Note 7 Terrain category definition according to section 4.2.1 of AS/NZS 1170.2:2021 as follows:
 Terrain Category 2 (TC2) - Open terrain, including grassland, with well-scattered obstructions having heights generally from 1.5 m to 5 m, with no more than two obstructions per hectare (e.g. farmland and cleared subdivisions with isolated trees and uncut grass).
 Terrain Category 3 (TC3) - Terrain with numerous closely spaced obstructions having heights generally from 3 m to 10 m. The minimum density of obstructions shall be at least the equivalent of 10 house-size obstructions per hectare (e.g. suburban housing, light industrial estates or dense forests).

Note 8 Wind regions are shown in Figure 3.1(B) of AS/NZS 1170.2:2021. (Refer to Appendix 1 for the high resolution images from standard if required)

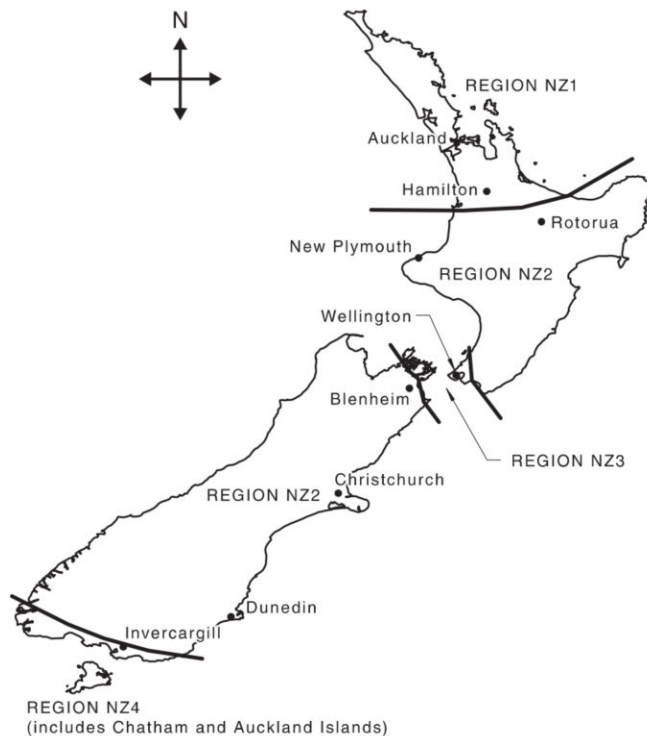

Figure 3.1(B) — Wind regions — New Zealand

Note 9 Base interface spacing to be multiplied by all applicable reduction/increase factors. Factored spacing less than one third of the panel width are not satisfied. (NOT SUITABLE FOR INSTALLATION)

Client: **CLENERGY AUSTRALIA**
 Project: **Tilt Array Frame System Spacing Table with ELITE Rails – Tin Roof (Pierced Fix Roof)**
 Address: **within New Zealand**

Job: **13924**
 Date: **Jan-25**
 Designed: **JD**
 Checked: **JG**

- Note 10 Wind direction multiplier (Md), Shielding multiplier (Ms) and Hill shape multiplier (Mh) are taken as 1.0.
- Note 11 Refer section 4.4 of AS/NZS 1170.2:2021 for Lee multiplier (Mlee) and topographic multiplier (Mt).
- Note 12 Lee multiplier (Mlee) is taken as 1.0 except for WR NZ1&NZ2 with Mlee which is taken as 1.35 and 1.2 separately. Refer section 4.4.1 of AS/NZS 1170.2:2021 for topographic multiplier (Mt). See Note 25 for Lee zones map.
- Note 13 The assessment includes the effect of earthquake loads. See note 27 for the fixing spacing determined by earthquake loads.
- Note 14 Alpine regions are excluded for snow assessment. See note 26 for the fixing spacing determined by snow loads.
- Note 15 Refer section 2.3 and Figure 2.2 of AS/NZS 1170.3:2003 for sub-alpine regions. Probability factor (kp) and Exposure reduction coefficient (Ce) are taken as 1.0 and Shape coefficient (μ) is taken as 0.7. See Note 26 for sub-alpine regions map.
- Note 16 Maximum panel weight is limited to 15kg/m².
- Note 17 Maximum panel width is limited to 1200mm.
- Note 18 Maximum rail and panel width overhang is limited to the 40% of the allowable interface spacing.
- Note 19 PV panels clamping zone to be according to the manufacturer's specifications.
- Note 20 This certificate is applicable for the corrosion zones C1, C2, C3, C4 and C5. Correspondent roof interface must be used for each zone. Refer SNZ TS 3404:2018 for corrosion zones definitions.
- Note 21 This assessment is based on the capacity of the fixings of array frame to the structure and the array frame itself but not PV panel nor roof structures. Other building structures are deemed to be satisfactory. It is the responsibility of the installer to adopt the most critical spacing.
- Note 22 Following reduction/increase factors to be applied to the base spacing for different type of tophat, purlin or batten or if timber screw embedment is reduced by fixing to smaller timber depth. **In any case, it is not applicable for installation if the actual fixing spacing after applying spacing ratio is less than 300mm.**

Purlin/Batten Material	Fixing Type		Purlin thickness (mm)	Min. Embedment (mm)	Spacing Reduction / Increase			
	Interface	No. of screws			WR NZ1&NZ2	WR NZ1&NZ2 with M _{lee}	WR NZ3	WR NZ4
Timber F7 (Pine)	Tin	1	-	25	-22%	-22%	-22%	-22%
Timber F7 (Pine)	Tin	2	-	25	0%	0%	0%	0%
Timber F7 (Pine)	Tin	1	-	30	-6%	-6%	-6%	-6%
Timber F7 (Pine)	Tin	2	-	30	0%	0%	0%	0%
Timber F7 (Pine)	Tin	1 or 2	-	35	0%	0%	0%	0%
Timber F17 (HW)	Tin	1 or 2	-	25	0%	0%	0%	0%
Timber F17 (HW)	Tin	1 or 2	-	30	0%	0%	0%	0%
Timber F17 (HW)	Tin	1 or 2	-	35	0%	0%	0%	0%
Metal (G550)	Tin	2	0.42	-	-60%	-60%	-60%	-60%
Metal (G550)	Tin	2	0.48	-	-54%	-54%	-54%	-54%
Metal (G550)	Tin	2	0.55	-	-48%	-48%	-48%	-48%
Metal (G550)	Tin	2	0.75	-	-29%	-29%	-29%	-29%
Metal (G450)	Tin	1	1.2	-	-38%	-38%	-38%	-38%
Metal (G450)	Tin	2	1.2	-	0%	0%	0%	0%
Metal (G450)	Tin	1	1.5	-	-22%	-22%	-22%	-22%
Metal (G450)	Tin	2	1.5	-	0%	0%	0%	0%
Metal (G450)	Tin	1 or 2	1.9	-	0%	0%	0%	0%
Metal (G450)	Tin	1 or 2	2.4	-	0%	0%	0%	0%

- Note 23 This certificate can be used for the installation of tilt legs on uncracked concrete roofs using one Chemset per tilt leg/bracket. The minimum pull-out tensile capacity of the fixing anchor must be higher than 5kN with drilled hole depth of 80mm. Concrete slab thickness to be minimum 150mm because of anchor cover requirement.
- Note 24 Following reduction/increase factors to be applied to the base spacing for different panel lengths. **In any case, the actual fixing spacing after applying spacing ratio is limited to maximum 2000mm**

Panel Length (mm)	No. of Rails	Spacing Reduction / Increase			
		WR NZ1&NZ2	WR NZ1&NZ2 with M _{lee}	WR NZ3	WR NZ4
1700	2	+5%	+17%	+5%	+5%
1800	2	+3%	+11%	+3%	+3%
1900	2	+2%	+4%	+2%	+2%
2000	2	0%	0%	0%	0%
2100	2	-6%	-6%	-6%	-6%
2200	2	-10%	-10%	-10%	-10%
2300	2	-14%	-14%	-14%	-14%
2400	2	-17%	-17%	-17%	-17%

Client: **CLENERGY AUSTRALIA**
 Project: **Tilt Array Frame System Spacing Table with ELITE Rails – Tin Roof (Pierced Fix Roof) within New Zealand**

Job: **13924**
 Date: **Jan-25**
 Designed: **JD**
 Checked: **JG**

Note 25 Interface spacing to be reduced as follows for sites in wind regions NZ1 & NZ2 with Mlee over 500m above sea level: (Refer to Appendix 2 for the high resolution images from standard if required)

Site Elevation, E (m)	Spacing Reduction
E < 500	0%
500 ≤ E < 700	-20%
700 ≤ E < 900	-24%
900 ≤ E < 1200	-31%
E ≥ 1200	N/A

North Island	
1	Kaimai
2	Taranaki
3	Ruapehu
4	Tararua
5	Tararua and Orongorongo
6	Coastal Wairarapa
South Island	
7	West Coast North
8	West Coast Alps
9	Awatere
10	Inland Kaikoura
11	Southern Alps
12	Hunter
13	Hakataramea
14	St Mary's
15	Pisa
16	Dunstan
17	Rock and Pillar

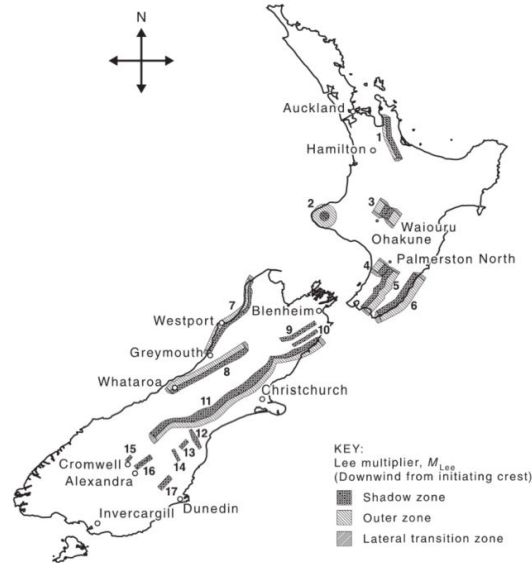

NOTE 1 Some outer and lateral transition zones are not shown.
 NOTE 2 For numbers shown, see the first column of Table 4.4.

Figure 4.6 — Locations of New Zealand lee zones

Note 26 Maximum Tin roof interface spacing in sub-alpine regions to be limited to follows for all roof zones. Lateral loading on array frame (due to accumulation snow under PV panels or exerted by drifts) has not been considered. Sub-alpine zone shown in Figure 2.2 of AS/NZS 1170.3:2003 (Refer to Appendix 3 for the high resolution images from standard if required)

Site Elevation, E (m)	No. of Rails	Maximum Interface Spacing (mm)			
		Snow Region N1	Snow Region N2&N3	Snow Region N4	Snow Region N5
E ≤ 100	2	N/A	N/A	N/A	1595
100 < E ≤ 200	2	N/A	1595	1390	1595
200 < E ≤ 300	2	N/A	1595	1280	1460
300 < E ≤ 400	2	N/A	1595	1200	1390
400 < E ≤ 500	2	1595	1400	1160	1315
500 < E ≤ 700	2	1390	1230	1085	1200
700 < E ≤ 900	2	1250	1125	1030	1120
900 < E ≤ 1200	2	1120	N/A	N/A	N/A

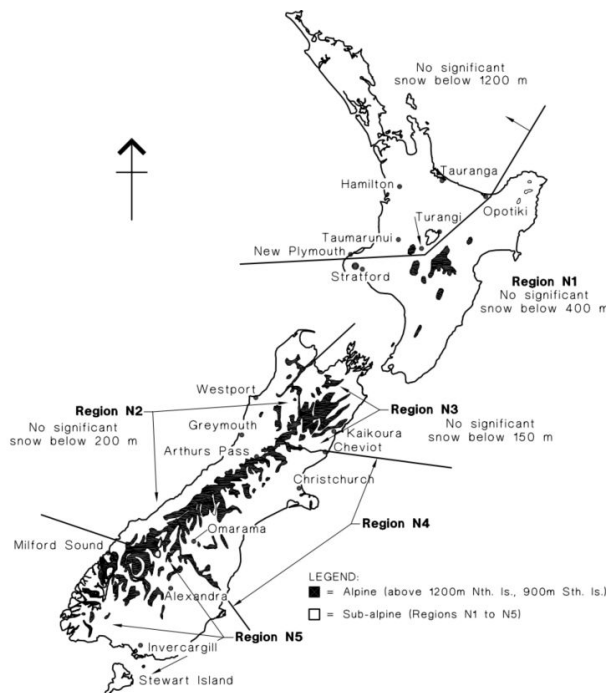

2.3 NEW ZEALAND

Alpine and sub-alpine regions are defined as follows:

- (a) N1 (southern portion of North Island of New Zealand, see Figure 2.2):
 - (i) Sub-alpine between 400 m and 1200 m.
 - (ii) Alpine ≥1200 m.
- (b) N2 (South Island of New Zealand):
 - (i) Sub-alpine between 200 m and 900 m.
 - (ii) Alpine ≥900 m.
- (c) N3 (South Island of New Zealand):
 - (i) Sub-alpine between 150 m and 900 m.
 - (ii) Alpine ≥900 m.
- (d) N4 and N5 (South Island of New Zealand):
 - (i) Sub-alpine <900 m.
 - (ii) Alpine ≥900 m.

NOTE: This map is approximate only and altitude above mean sea level shall be used to determine snow region. For sub-alpine regions in the South Island (N2, N3, N4 and N5) the regions coincide with the 1988 county boundaries. Where an alpine region exists between sub-alpine regions, the alpine region separates the 2 sub-alpine regions (which extend downwards from 1200 m altitude).

FIGURE 2.2 NEW ZEALAND—APPROXIMATE LOCATIONS OF ALPINE AND SUB-ALPINE REGIONS

Client: **CLENERGY AUSTRALIA**
 Project: **Tilt Array Frame System Spacing Table with ELITE Rails – Tin Roof (Pierced Fix Roof)**
 Address: **within New Zealand**

Job: **13924**
 Date: **Jan-25**
 Designed: **JD**
 Checked: **JG**

Note 27 Refer table 3 and Figure 2 of NZS 4219:2009 for zone factor (Z). Performance factor (Cp) is taken as 0.85 and Component risk factor (Rc) coefficient (Ce) is taken as 1.0 and High coefficient (Ch) is taken as 3. Maximum Tilt mount interface spacing in Earthquake zone to be limited to follows for all roof zones. (Refer to Appendix 4 for the high resolution images from standard if required)

Earthquake Zone, Z (m)	No. of Rails	Maximum Interface Spacing (mm)				
		Max Panel Length 2000mm	Max Panel Length 2100mm	Max Panel Length 2200mm	Max Panel Length 2300mm	Max Panel Length 2400mm
Z ≤ 0.13	2	2000	1985	1965	1945	1920
0.13 < Z ≤ 0.15	2	1940	1915	1895	1875	1855
0.15 < Z ≤ 0.18	2	1855	1830	1810	1785	1765
0.18 < Z ≤ 0.20	2	1805	1780	1755	1725	1700
0.20 < Z ≤ 0.23	2	1725	1700	1675	1650	1625
0.23 < Z ≤ 0.26	2	1655	1630	1605	1580	1560
0.26 < Z ≤ 0.30	2	1580	1555	1530	1510	1485
0.30 < Z ≤ 0.35	2	1500	1475	1455	1430	1410
0.35 < Z ≤ 0.40	2	1435	1410	1390	1370	1350
0.40 < Z ≤ 0.45	2	1380	1360	1335	1315	1300
0.45 < Z ≤ 0.50	2	1330	1310	1290	1270	1245
0.50 < Z ≤ 0.55	2	1290	1270	1235	1180	1130
0.55 < Z ≤ 0.60	2	1245	1185	1130	1080	1035

Note:
 The seismic assessment is based on the rail capacity and shear capacity of fixings.

Table 3 – Zone factors for New Zealand locations (north to south)

#	Location	Z
1	Kaitiaki	0.13
2	Pahia/Russell	0.13
3	Kaikohe	0.13
4	Whangarei	0.13
5	Dargaville	0.13
6	Warkworth	0.13
7	Auckland	0.13
8	Manakau City	0.13
9	Waikuku	0.13
10	Pukekohe	0.13
11	Thames	0.16
12	Paeroa	0.18
13	Waihi	0.18
14	Huntly	0.15
15	Ngaruawahia	0.15
16	Morrinsville	0.18
17	Te Aroha	0.18
18	Tauranga	0.20
19	Mount Maunganui	0.20
20	Hamilton	0.16
21	Cambridge	0.18
22	Te Awamutu	0.17
23	Matamata	0.19
24	Te Puke	0.22
25	Putaruru	0.21
26	Tokoroa	0.21
27	Otorohanga	0.17
28	Te Kuiti	0.18
29	Mangakino	0.21
30	Rotorua	0.24
31	Kawerau	0.29
32	Whakatane	0.30
33	Opotiki	0.30
34	Ruatoria	0.33
35	Murupara	0.30

Table 3 – Zone factors for New Zealand locations (north to south) (continued)

#	Location	Z
36	Taupo	0.28
37	Taumarunui	0.21
38	Turangi	0.27
39	Gisborne	0.36
40	Wairoa	0.37
41	Waitara	0.18
42	New Plymouth	0.18
43	Inglewood	0.18
44	Stratford	0.18
45	Opunake	0.18
46	Hawera	0.18
47	Patea	0.19
48	Raetihi	0.26
49	Ohakune	0.27
50	Waiouru	0.29
51	Napier	0.38
52	Hastings	0.39
53	Wanganui	0.25
54	Waipawa	0.41
55	Waipukurau	0.41
56	Taihape	0.33
57	Marton	0.30
58	Bulls	0.31
59	Feilding	0.37
60	Palmerston North	0.38
61	Dannevirke	0.42
62	Woodville	0.41
63	Pahiatua	0.42
64	Foxton/Foxton Beach	0.36
65	Levin	0.40
66	Otaki	0.40
67	Waikanae	0.40
68	Paraparaumu	0.40
69	Masterton	0.42

#	Location	Z
70	Porirua	0.40
71	Wellington CBD (north of Basin Reserve)	0.40
72	Wellington	0.40
73	Hutt Valley – south of Taia Gorge	0.40
74	Upper Hutt	0.42
75	Eastbourne – Point Howard	0.40
76	Wainuiomata	0.40
77	Takaka	0.23
78	Motueka	0.26
79	Nelson	0.27
80	Picton	0.30
81	Blenheim	0.33
82	St Arnaud	0.36
83	Westport	0.30
84	Reefton	0.37
85	Murchison	0.34
86	Springs Junction	0.45
87	Hanmer Springs	0.55
88	Seddon	0.40
89	Ward	0.40
90	Cheviot	0.40
91	Greymouth	0.37
92	Kaikoura	0.42
93	Harihari	0.46
94	Hokitika	0.45
95	Fox Glacier	0.44
96	Franz Josef	0.44
97	Otira	0.60
98	Arthurs Pass	0.60
99	Rangiora	0.33
100	Darfield	0.30
101	Akaroa	0.16

#	Location	Z
102	Christchurch	0.22
103	Geraldine	0.19
104	Ashburton	0.20
105	Fairlie	0.24
106	Temuka	0.17
107	Timaru	0.15
108	Mt Cook	0.38
109	Twizel	0.27
110	Waimate	0.14
111	Cromwell	0.24
112	Wanaka	0.30
113	Arrowtown	0.30
114	Alexandra	0.21
115	Queenstown	0.32
116	Milford Sound	0.54
117	Palmerston	0.13
118	Oamaru	0.13
119	Dunedin	0.13
120	Mosgiel	0.13
121	Riverton	0.20
122	Te Anau	0.36
123	Gore	0.18
124	Winton	0.20
125	Balclutha	0.13
126	Mataura	0.17
127	Bluff	0.15
128	Invercargill	0.17
129	Oban	0.14

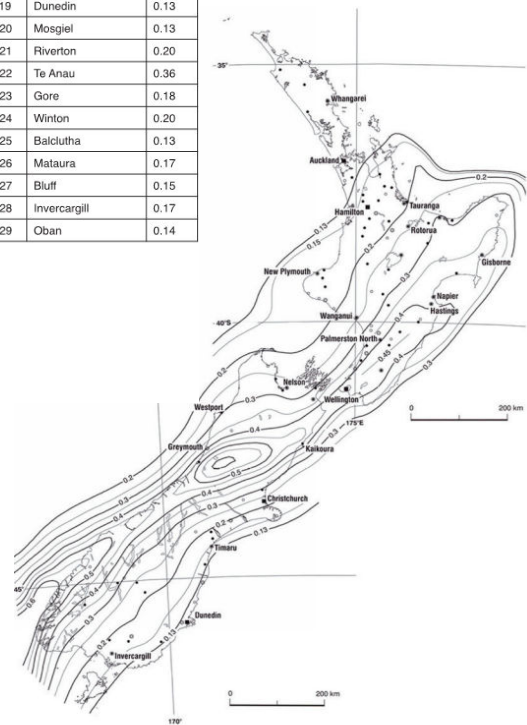

Figure 2 – Zone factor, Z

Client: **CLENERGY AUSTRALIA**
 Project: **Tilt Array Frame System Spacing Table with ELITE Rails – Tin Roof (Pierced Fix Roof)**
 Address: **within New Zealand**

Job: **13924**
 Date: **Jan-25**
 Designed: **JD**
 Checked: **JG**

Note 28 Building height is average roof height of structure above ground. Refer Figure 1 for definition of h, d and b.

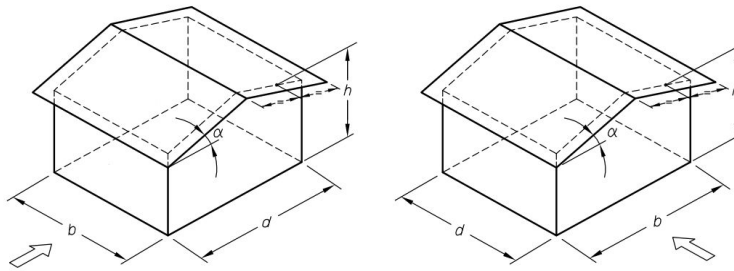
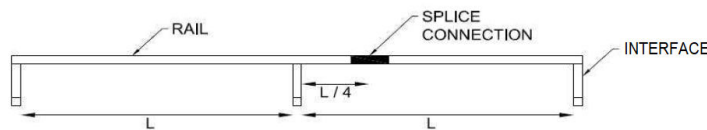

Figure 1 - h, d and b definition

Note 29 Rail splice connection must be placed at a quarter length of the spacing of interface. No Splice connection should be placed at the centre of spacing or over the interface.



Note 30 Refer Figure 2 for definition of roof zones. The smallest spacing to be used for panels fall between two (or more) roof zones.

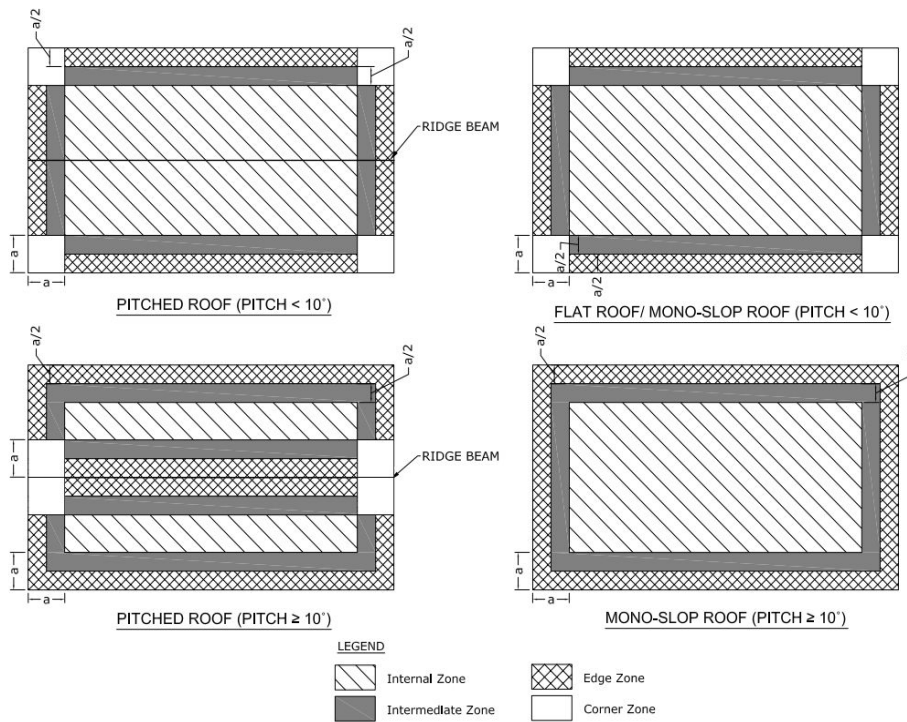

Figure 2- Roof Zones Definition

In Figure 2, the value of dimension "a" is the minimum of 0.2b or 0.2d, if (h/b) or (h/d) ≥ 0.2; or 2h if both (h/b) and (h/d) < 0.2 (b & d are building dimensions and h is average roof height, see Figure 1)

Note 31 Perpendicular installation (rails to purlins) for roofs with roof pitch greater than 10 degrees is not covered by this certification.

Note 32 Installation of solar array to be done in accordance with the relevant Clenergy PV installation manual. Contact Clenergy if you are unable to comply with any of the above installation specifications.

Client: **CLENERGY AUSTRALIA**
 Project: **Tilt Array Frame System Spacing Table with ELITE Rails – Tin Roof (Pierced Fix Roof) within New Zealand**
 Address: **within New Zealand**

Job: **13924**
 Date: **Jan-25**
 Designed: **JD**
 Checked: **JG**

Examples

Example 1	Tin Roof		factor		
	Wind Region	NZ1	-	Final factor	1
	Terrain Category	2	-		
	Building Height	6.5m	-	Roof Zone	Final Spacing
	Tilt angle	20°	-	Internal Zone	990mm
	Panel Dimension	2m x 1m	1	Intermediate Zone	645mm
	Purlin Thickness	1.5mm	1	Edge Zone	480mm
	No. of screws	2	1	Corner Zone	--
Example 2	Tin Roof		factor		
	Wind Region	NZ2, with Mlee of 1.35	-	Final factor	0.89
	Terrain Category	3	-		
	Building Height	12m	-	Roof Zone	Final Spacing
	Tilt angle	22°	-	Internal Zone	590mm
	Panel Dimension	1.75m x 1m	1.11	Intermediate Zone	--
	Purlin Thickness	1.9mm	1	Edge Zone	--
	No. of screws	2	1	Corner Zone	--
	Site Elevation	600m	0.80		
	Sub-alpine Region	N2 (E=600m)	-		
Example 3	Tin Roof		factor		
	Wind Region	NZ3	-	Final factor	1
	Terrain Category	3	-		
	Building Height	5m	-	Roof Zone	Final Spacing
	Tilt angle	10°	-	Internal Zone	1390mm*
	Panel Dimension	2m x 1.1m	1	Intermediate Zone	1000mm
	Purlin Thickness	2.4mm	1	Edge Zone	735mm
	No. of screws	1	1	Corner Zone	485mm
	Sub-alpine Region	N1 (E=600m)	*	(From Note 26, the maximum spacing is 1390mm, which is determined by snow)	
Example 4	Tile Roof		factor		
	Wind Region	NZ4	-	Final factor	1.05
	Terrain Category	2	-		
	Building Height	5m	-	Roof Zone	Final Spacing
	Tilt angle	25°	-	Internal Zone	1005mm
	Panel Dimension	1.65m x 1.1m	1.05	Intermediate Zone	660mm
	Embedment F17	30mm	1	Edge Zone	485mm
	No. of screws	2	1	Corner Zone	--
	Sub-alpine Region	N5 (E=200m)	-	(From Note 26, the maximum spacing is 1595mm, which is determined by snow)	
Example 5	Tin Roof		factor		
	Wind Region	NZ2, with Mlee of 1.20	-	Final factor	0.63
	Terrain Category	3	-		
	Building Height	10m	-	Roof Zone	Final Spacing
	Tilt angle	15°	-	Internal Zone	885mm
	Panel Dimension	2.40m x 1.1m	0.83	Intermediate Zone	585mm
	Purlin Thickness	1.9mm	1	Edge Zone	430mm
	No. of screws	2	1	Corner Zone	--
	Site Elevation	700mm	0.76		
	Sub-alpine Region	N5 (E=700m)	-	(From Note 26, the maximum spacing is 1200mm, which is determined by snow)	
			Earthquake zone, Z 0.6 (Arthurs pass)		
			(From Note 27, the maximum spacing is 1035mm, which is determined by earthquake)		

Appendix

1. Refer Figure 3.1(B) of AS/NZS 1170.2:2021 for the wind region

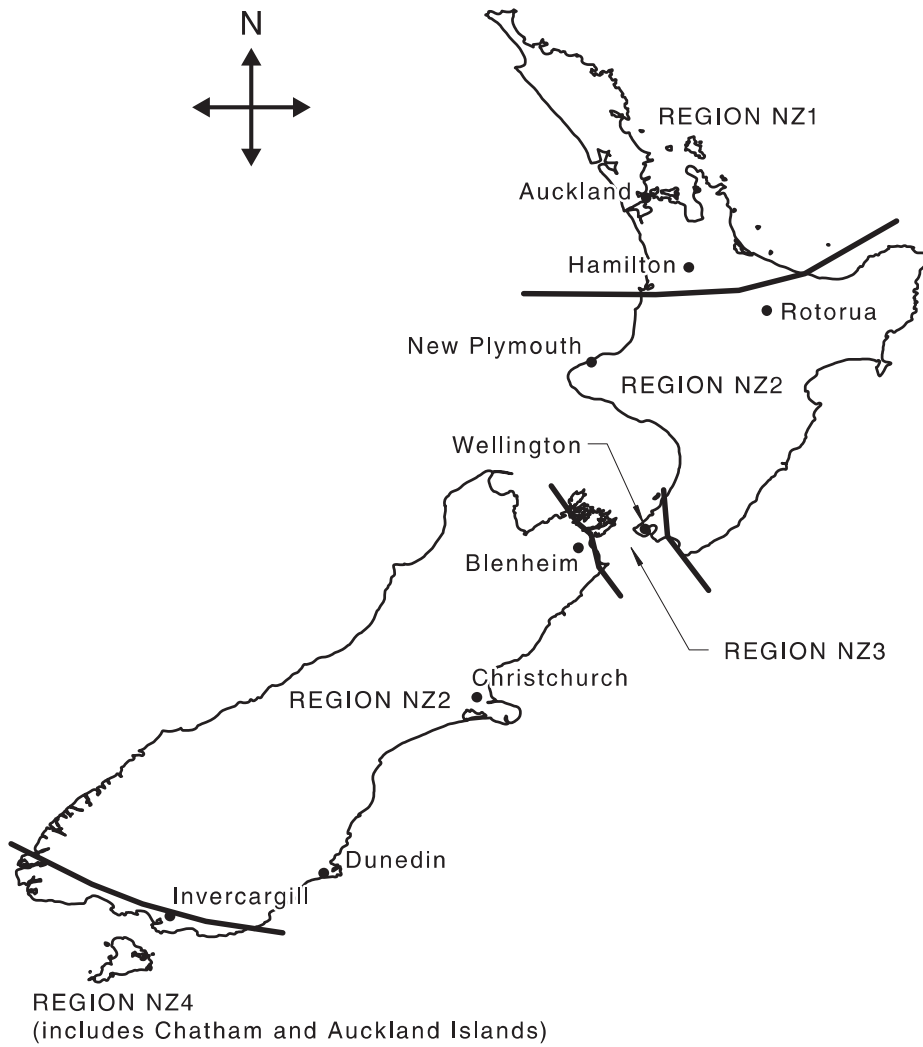
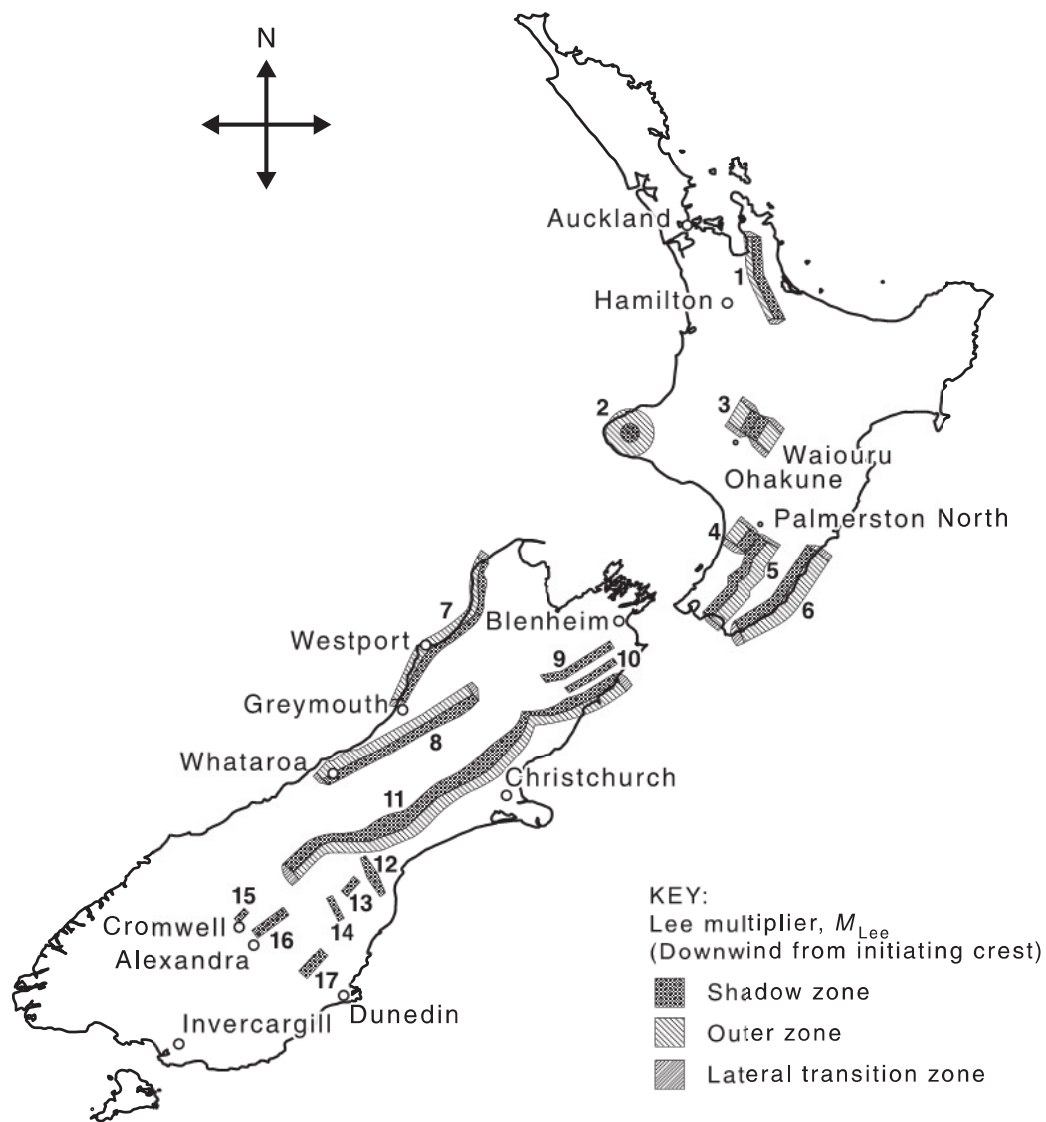

Figure 3.1(B) — Wind regions — New Zealand

2. Refer Table 4.4 and Figure 4.6 of AS/NZS 1170.2:2021 for the location of New Zealand Lee zone

Table 4.4 — New Zealand lee zones direction and extent of shadow and outer zones

Range		Direction	M_{lee}	Shadow (km)	Outer (km)
North Island					
1.	Kaimai	E&SE	1.20	0 to 8	8 to 20
2.	Taranaki	Any, taken to be 90° sector from mountain top downwind to location	1.35	0 to 12	12 to 30
3.	Ruapehu	NW and SE	1.35	0 to 12	12 to 30
4.	Tararua	SE	1.20	0 to 8	8 to 20
5.	Tararua and Orongorongo	NW	1.20	0 to 8	8 to 20
6.	Coastal Wairarapa	NW			
South Island					
7.	West Coast North	E and SE	1.20	0 to 8	8 to 20
8.	West Coast Alps	SE	1.35	0 to 12	12 to 30
9.	Awatere	NW	1.35	0 to 12	(within Inland Kaikoura)
10.	Inland Kaikoura	NW	1.35	0 to 12	(within Southern Alps)
11.	Southern Alps	NW	1.35	0 to 12	12 to 30
12.	Hunter	SW	1.20	0 to 8	8 to 20
13.	Hakataramea	NW	1.20	0 to 8	8 to 20
14.	St Mary's	SW	1.20	0 to 8	8 to 20
15.	Pisa	NW	1.20	0 to 8	8 to 20
16.	Dunstan	NW	1.20	0 to 8	8 to 20
17.	Rock and Pillar	NW	1.20	0 to 8	8 to 20



NOTE 1 Some outer and lateral transition zones are not shown.

NOTE 2 For numbers shown, see the first column of [Table 4.4](#).

Figure 4.6 — Locations of New Zealand lee zones

3. Refer section 2.3 and Figure 2.2 of AS/NZS 1170.3:2003 for Sub-alpine zone the location of New Zealand Lee zone

2.3 NEW ZEALAND

Alpine and sub-alpine regions are defined as follows:

- (a) N1 (southern portion of North Island of New Zealand, see Figure 2.2):
 - (i) Sub-alpine between 400 m and 1200 m.
 - (ii) Alpine ≥ 1200 m.
- (b) N2 (South Island of New Zealand):
 - (i) Sub-alpine between 200 m and 900 m.
 - (ii) Alpine ≥ 900 m.
- (c) N3 (South Island of New Zealand):
 - (i) Sub-alpine between 150 m and 900 m.
 - (ii) Alpine ≥ 900 m.
- (d) N4 and N5 (South Island of New Zealand):
 - (i) Sub-alpine < 900 m.
 - (ii) Alpine ≥ 900 m.

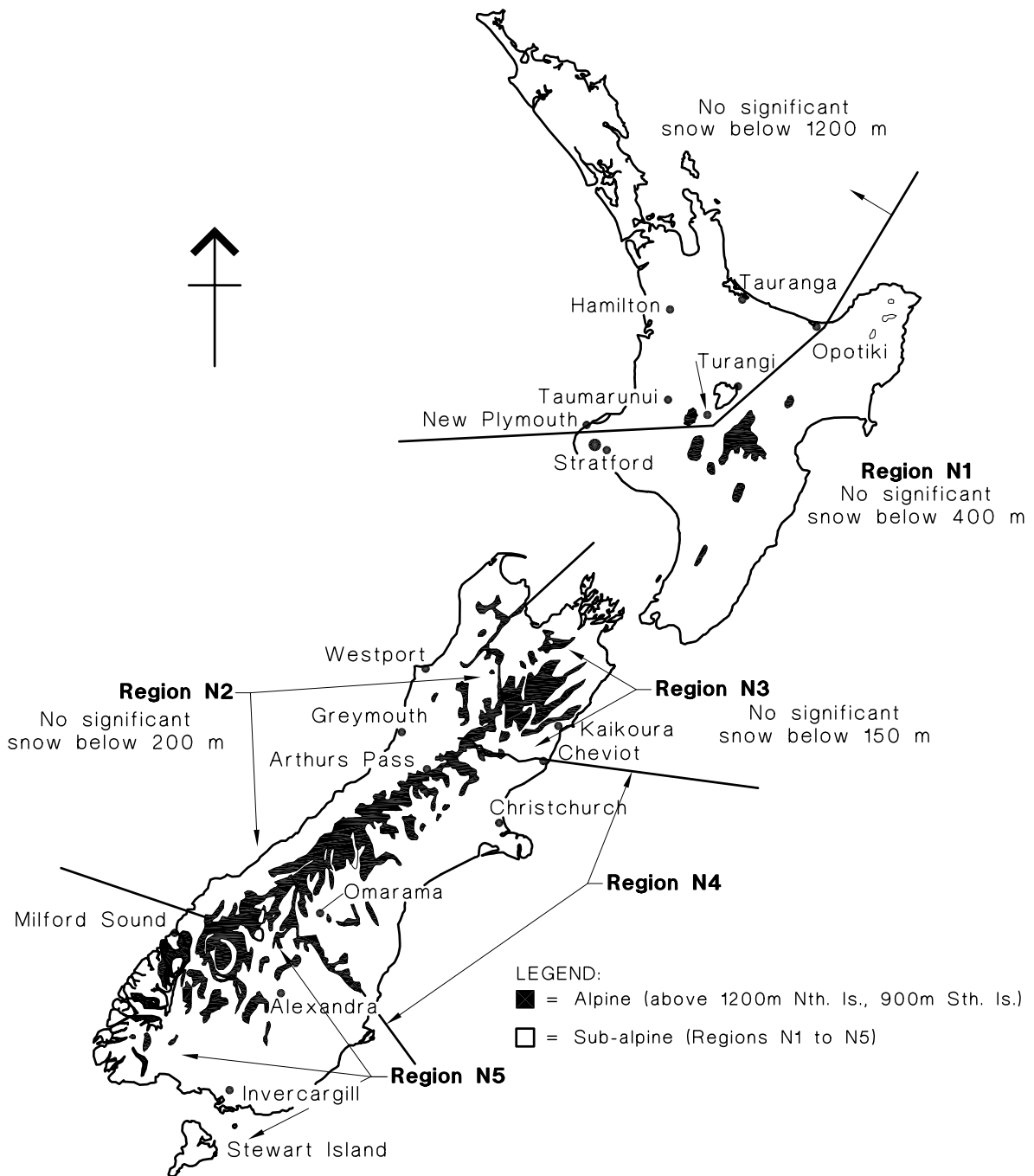

NOTE: This map is approximate only and altitude above mean sea level shall be used to determine snow region. For sub-alpine regions in the South Island (N2, N3, N4 and N5) the regions coincide with the 1988 county boundaries. Where an alpine region exists between sub-alpine regions, the alpine region separates the 2 sub-alpine regions (which extend downwards from 1200 m altitude).

FIGURE 2.2 NEW ZEALAND—APPROXIMATE LOCATIONS OF ALPINE AND SUB-ALPINE REGIONS

4. Refer table 3 and Figure 2 of NZS 4219:2009 for zone factor (Z)

Table 3 – Zone factors for New Zealand locations (north to south)

#	Location	Z
1	Kaitaia	0.13
2	Paihia/Russell	0.13
3	Kaikohe	0.13
4	Whangarei	0.13
5	Dargaville	0.13
6	Warkworth	0.13
7	Auckland	0.13
8	Manakau City	0.13
9	Waiuku	0.13
10	Pukekohe	0.13
11	Thames	0.16
12	Paeroa	0.18
13	Waihi	0.18
14	Huntly	0.15
15	Ngaruawahia	0.15
16	Morrinsville	0.18
17	Te Aroha	0.18
18	Tauranga	0.20
19	Mount Maunganui	0.20
20	Hamilton	0.16
21	Cambridge	0.18
22	Te Awamutu	0.17
23	Matamata	0.19
24	Te Puke	0.22
25	Putaruru	0.21
26	Tokoroa	0.21
27	Otorohanga	0.17
28	Te Kuiti	0.18
29	Mangakino	0.21
30	Rotorua	0.24
31	Kawerau	0.29
32	Whakatane	0.30
33	Opotiki	0.30
34	Ruatoria	0.33
35	Murupara	0.30

#	Location	Z
36	Taupo	0.28
37	Taumarunui	0.21
38	Turangi	0.27
39	Gisborne	0.36
40	Wairoa	0.37
41	Waitara	0.18
42	New Plymouth	0.18
43	Inglewood	0.18
44	Stratford	0.18
45	Opunake	0.18
46	Hawera	0.18
47	Patea	0.19
48	Raetihi	0.26
49	Ohakune	0.27
50	Waiouru	0.29
51	Napier	0.38
52	Hastings	0.39
53	Wanganui	0.25
54	Waipawa	0.41
55	Waipukurau	0.41
56	Taihape	0.33
57	Marton	0.30
58	Bulls	0.31
59	Feilding	0.37
60	Palmerston North	0.38
61	Dannevirke	0.42
62	Woodville	0.41
63	Pahiatua	0.42
64	Foxton/Foxton Beach	0.36
65	Levin	0.40
66	Otaki	0.40
67	Waikanae	0.40
68	Paraparaumu	0.40
69	Masterton	0.42

Table 3 – Zone factors for New Zealand locations (north to south) (continued)

#	Location	Z
70	Porirua	0.40
71	Wellington CBD (north of Basin Reserve)	0.40
72	Wellington	0.40
73	Hutt Valley – south of Taita Gorge	0.40
74	Upper Hutt	0.42
75	Eastbourne – Point Howard	0.40
76	Wainuiomata	0.40
77	Takaka	0.23
78	Motueka	0.26
79	Nelson	0.27
80	Picton	0.30
81	Blenheim	0.33
82	St Arnaud	0.36
83	Westport	0.30
84	Reefton	0.37
85	Murchison	0.34
86	Springs Junction	0.45
87	Hanmer Springs	0.55
88	Seddon	0.40
89	Ward	0.40
90	Cheviot	0.40
91	Greymouth	0.37
92	Kaikoura	0.42
93	Harihari	0.46
94	Hokitika	0.45
95	Fox Glacier	0.44
96	Franz Josef	0.44
97	Otira	0.60
98	Arthurs Pass	0.60
99	Rangiora	0.33
100	Darfield	0.30
101	Akaroa	0.16

#	Location	Z
102	Christchurch	0.22
103	Geraldine	0.19
104	Ashburton	0.20
105	Fairlie	0.24
106	Temuka	0.17
107	Timaru	0.15
108	Mt Cook	0.38
109	Twizel	0.27
110	Waimate	0.14
111	Cromwell	0.24
112	Wanaka	0.30
113	Arrowtown	0.30
114	Alexandra	0.21
115	Queenstown	0.32
116	Milford Sound	0.54
117	Palmerston	0.13
118	Oamaru	0.13
119	Dunedin	0.13
120	Mosgiel	0.13
121	Riverton	0.20
122	Te Anau	0.36
123	Gore	0.18
124	Winton	0.20
125	Balclutha	0.13
126	Mataura	0.17
127	Bluff	0.15
128	Invercargill	0.17
129	Oban	0.14

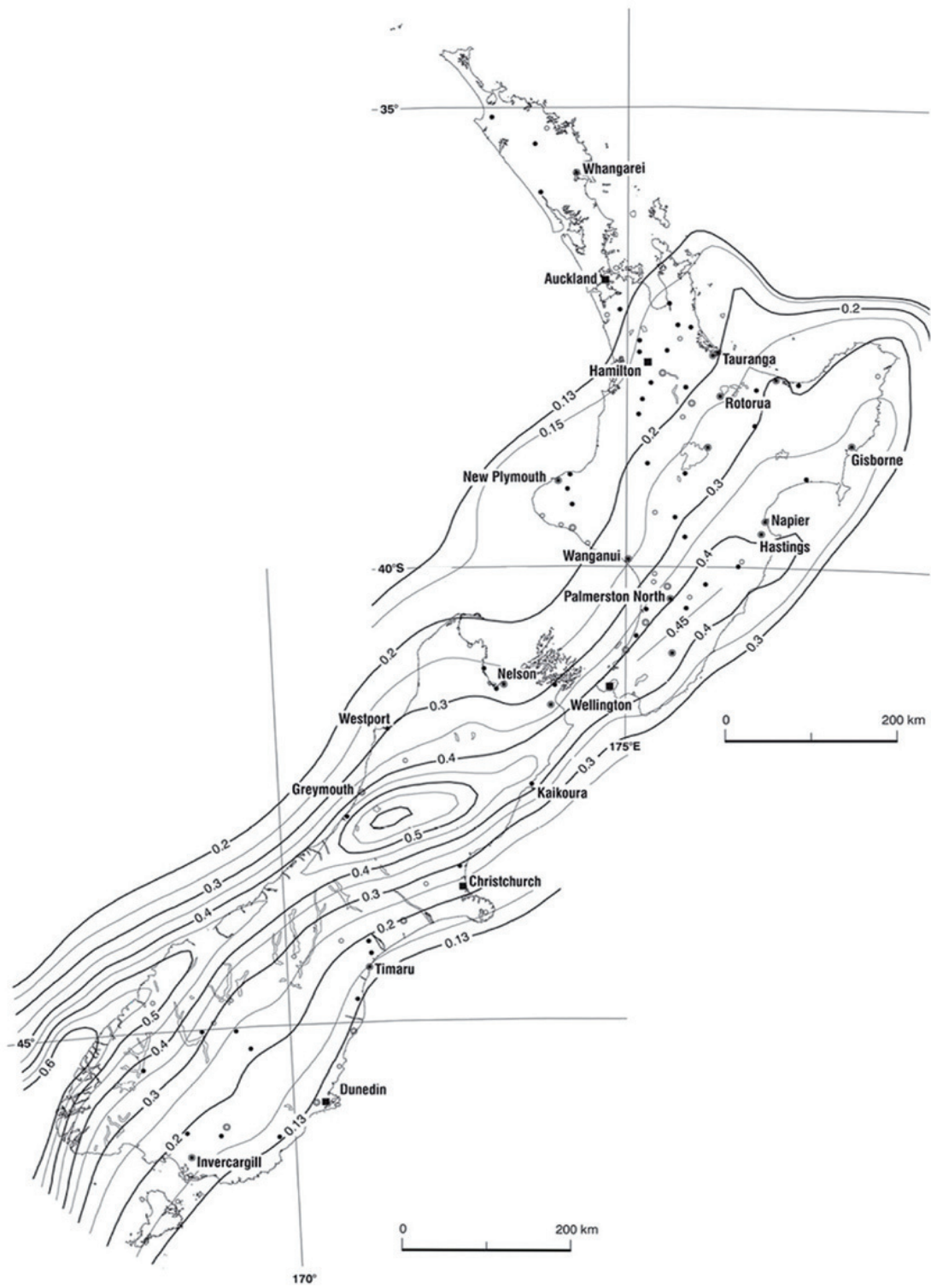

Figure 2 – Zone factor, Z

Certificate User Guideline



association of consulting and engineering

Building Code Clause(s) B1

PRODUCER STATEMENT – PS1 – DESIGN

ISSUED BY: Gamcorp Pty Ltd
(Design Firm)

TO: Clenergy Australia
(Owner/Developer)

TO BE SUPPLIED TO:
(Building Consent Authority)

IN RESPECT OF: Clenergy PV-ezRack SolarRoof Flush and Tilt Roof Mount systems with ER-R-ECO & ER-R-ELT Penetrative fixing

AT: Within New Zealand
(Address)

Town/City: **LOT** **DP** **SO**
(Address)

We have been engaged by the owner/developer referred to above to provide:

The assessment according to the capacity of the fixing of the array frame to the roof structure and the array frame itself for roof top solar panel installation.
PV panel and building structure including roof structure are excluded.

(Extent of Engagement)

services in respect of the requirements of Clause(s) B1 of the Building Code for:

All or Part only (as specified in the attachment to this statement), of the proposed building work.

The design carried out by us has been prepared in accordance with:

Compliance Documents issued by the Ministry of Business, Innovation & Employment or
(verification method/acceptable solution)

Alternative solution as per the attached schedule. refer Certification Letter 13708-01(Eco Rail) & 13924-01(Elite Rail) for Flush Mount system & 13708-02 (Eco Rail) & 13924-02(Elite Rail) for Tilt Mount system

The proposed building work covered by this producer statement is described on the drawings titled:

..... and numbered together with the specification, and other documents set out in the schedule attached to this statement.

On behalf of the Design Firm, and subject to: refer Certification Letter 13708-01(Eco Rail) & 13924-01(Elite Rail) for Flush

(i) Site verification of the following design assumptions Mount system & 13708-02 (Eco Rail) & 13924-02(Elite Rail) for Tilt Mount system
(ii) All proprietary products meeting their performance specification requirements;

I believe on reasonable grounds that a) the building, if constructed in accordance with the drawings, specifications, and other documents provided or listed in the attached schedule, will comply with the relevant provisions of the Building Code and that b), the persons who have undertaken the design have the necessary competency to do so. I also recommend the following level of construction monitoring/observation:

CM1 CM2 CM3 CM4 CM5 (Engineering Categories)

I, L. Van Spaandonk am: CPEng # CMEngNZ 2003796
(Name of Design Professional)

I am a member of: Engineering New Zealand and hold the following qualifications: FIE/Aust CPEng NER APEC Engineer InPE(Aus) CMEngNZ

The Design Firm issuing this statement holds a current policy of Professional Indemnity Insurance no less than \$200,000*.

The Design Firm is a member of ACE New Zealand:

SIGNED BY L. Van Spaandonk (Signature)

ON BEHALF OF Gamcorp Pty Ltd Date: 24/01/2025
(Design Firm)

Note: This statement shall only be relied upon by the Building Consent Authority named above. Liability under this statement accrues to the Design Firm only. The total maximum amount of damages payable arising from this statement and all other statements provided to the Building Consent Authority in relation to this building work, whether in contract, tort or otherwise (including negligence), is limited to the sum of \$200,000.*

This form is to accompany **Form 2 of the Building (Forms) Regulations 2004** for the application of a Building Consent.
THIS FORM AND ITS CONDITIONS ARE COPYRIGHT TO ACE NEW ZEALAND AND ENGINEERING NEW ZEALAND

GUIDANCE ON USE OF PRODUCER STATEMENTS

Producer statements were first introduced with the Building Act 1991. The producer statements were developed by a combined task committee consisting of members of the New Zealand Institute of Architects, Institution of Professional engineers New Zealand (now Engineering New Zealand), ACE New Zealand in consultation with the Building Officials Institute of New Zealand. The original suit of producer statements has been revised at the date of this form as a result of enactment of the Building Act (2004) by these organisations to ensure standard use within the industry.

The producer statement system is intended to provide Building Consent Authorities (BCAs) with reasonable grounds for the issue of a Building Consent or a Code Compliance Certificate, without having to duplicate design or construction checking undertaken by others.

PS1 Design Intended for use by a suitably qualified independent design professional in circumstances where the BCA accepts a producer statement for establishing reasonable grounds to issue a Building Consent;

PS2 Design Review Intended for use by a suitably qualified independent design professional where the BCA accepts an independent design professional's review as the basis for establishing reasonable grounds to issue a Building Consent;

PS3 Construction Forms commonly used as a certificate of completion of building work are Schedule 6 of NZS 3910:2013 or Schedules E1/E2 of NZIA's SCC 2011²

PS4 Construction Review Intended for use by a suitably qualified independent design professional who undertakes construction monitoring of the building works where the BCA requests a producer statement prior to issuing a Code Compliance Certificate.

This must be accompanied by a statement of completion of building work (Schedule 6).

The following guidelines are provided by ACE New Zealand and Engineering New Zealand to interpret the Producer Statement.

Competence of Design Professional

This statement is made by a Design Firm that has undertaken a contract of services for the services named, and is signed by a person authorised by that firm to verify the processes within the firm and competence of its designers.

A competent design professional will have a professional qualification and proven current competence through registration on a national competence based register as a Chartered Professional Engineer (CPEng).

Membership of a professional body, such as Engineering New Zealand (formerly IPENZ) provides additional assurance of the designer's standing within the profession. If the design firm is a member of ACE New Zealand, this provides additional assurance about the standing of the firm.

Persons or firms meeting these criteria satisfy the term "suitably qualified independent design professional".

*Professional Indemnity Insurance

As part of membership requirements, ACE New Zealand requires all member firms to hold Professional Indemnity Insurance to a minimum level.

The PI Insurance minimum stated on the front of this form reflects standard, small projects. If the parties deem this inappropriate for large projects the minimum may be up to \$500,000.

Professional Services during Construction Phase

There are several levels of service which a Design Firm may provide during the construction phase of a project (CM1-CM5 for Engineers³). The Building Consent Authority is encouraged to require that the service to be provided by the Design Firm is appropriate for the project concerned.

Requirement to provide Producer Statement PS4

Building Consent Authorities should ensure that the applicant is aware of any requirement for producer statements for the construction phase of building work at the time the building consent is issued as no design professional should be expected to provide a producer statement unless such a requirement forms part of the Design firm's engagement.

Attached Particulars

Attached particulars referred to in this producer statement refer to supplementary information appended to the producer statement.

Refer Also:

- 1 Conditions of Contract for Building & Civil Engineering Construction
NZS 3910: 2013
- 2 NZIA Standard Conditions of Contract SCC 2011

Guideline on the Briefing & Engagement for Consulting Engineering Services
(ACE New Zealand/Engineering New Zealand 2004)
- 4 PN Guidelines on Producer Statements

www.acenz.org.nz
www.engineeringnz.org



association of
consulting and
engineering



Clenergy

3/10 Duerdin St
Clayton VIC 3168
Australia

Phone: +61 3 9239 8088
Email: sales@clenergy.com.au
Web: www.clenergy.com.au

 @ClenergyGlobal / @ClenergyClub / @ClenergyAUS / @ClenergyThailand
 @Clenergy_global  @Clenergy  @Clenergy  @ClenergyClub

A Clenergy Technologies Company