

# Terracotta Tile

Code-Compliant Planning and Installation Guide V 1.0  
Complying with AS/NZS1170.2-2011 AMDT 2-2016

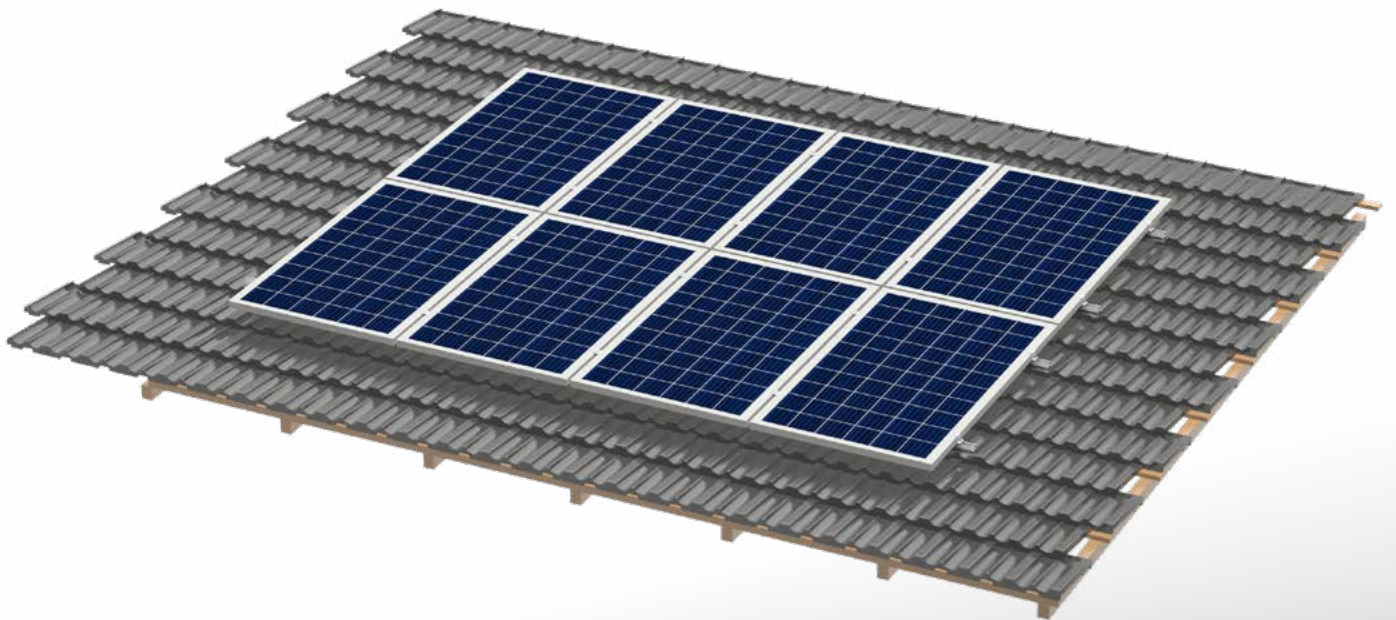

# Introduction

The Clenergy PV-ezRack® SolarRoof has been developed as a universal PV-mounting system for roof-mounting on pitched and flat roofs. The use of patented aluminium base rails, Z-Module technology and telescopic mounting technology eliminates custom cutting and enables fast installation.

Please review this manual thoroughly before installing PV-ezRack® SolarRoof. This manual provides:

- 1) Supporting documentation for building permit applications relating to PV-ezRack® SolarRoof Universal PV Module Mounting System.
- 2) Planning and installation instructions.

## List of contents

Introduction	01
Planning	02
Tools & Components	06
System Overview	08
Installation Instructions	10
Certification	18

The PV-ezRack® SolarRoof parts, when installed in accordance with this guide, will be structurally sound and will meet the AS/NZS1170.2:2011 Amdt 2- 2016 standard. During installation, and especially when working on the roof, please comply with the appropriate Occupational Health and Safety regulations. Please also pay attention to any other relevant State or Federal regulations. Please check that you are using the latest version of the Installation Manual, which you can do by contacting Clenergy Australia via email on [tech@clenergy.com.au](mailto:tech@clenergy.com.au) or contacting your local distributor in Australia.

### Product Warranty:

Please refer [PV-ezRack® Product Warranty](#) on our website.

### The installer is solely responsible for:

- Complying with all applicable local or national building codes, including any that may supersede this manual.
- Ensuring that PV-ezRack® and other products are appropriate for the particular installation and the installation environment.
- Using only PV-ezRack® parts and installer-supplied parts as specified by the PV-ezRack® project plan. (substitution of parts may void the warranty and invalidate the letter of certification).
- Recycling: Recycle: according to the local relative statute.
- Removal: Reverse installation process.
- Ensure that there are no less than two professionals working on panel installation.
- Ensure the installation of related electrical equipment is performed by licenced electricians.
- Ensuring safe installation of all electrical aspects of the PV array. This includes adequate earth bonding of the PV array and PV-ezRack® SolarRoof components as required in AS/NZS 5033: 2021.
- Ensuring that the roof, its rafters/purlins, connections, and other structural support members can support the array under building live load conditions.
- Ensuring that screws to fix interfaces have adequate pull-out strength and shear capacities as installed.
- Maintaining the waterproof integrity of the roof, including selection of appropriate flashing.
- Verifying the compatibility of the installation considering preventing electrochemical corrosion between dissimilar metals. This may occur between structures and the building and between structures, fasteners and PV modules, as detailed in AS/NZS 5033: 2021;
- Verifying atmospheric corrosivity zone of installation site by referring to AS 4312-2008 or consulting local construction business to determine appropriate products and installations.products and installations.

# Planning

Determine the wind region of your installation site

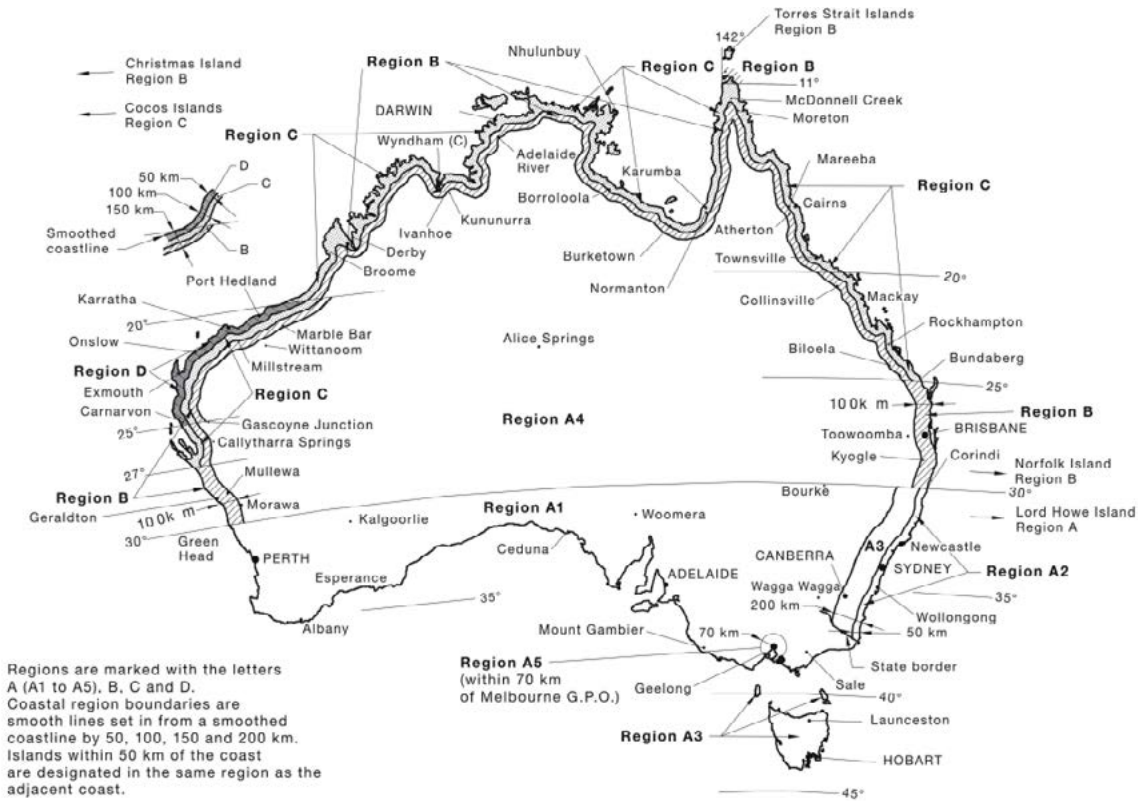

## Region Definition:

Wind regions are pre-defined for the whole of Australia by the Australian Standard 1170.2. The Wind Region is an independent factor of surrounding topography or buildings.

- Most of Australia is designated Region A which indicates a Regional Wind Velocity of 43 m/s with wind average recurrence of 200 years.
- Some areas are designated Region B (52 m/s). Local authorities will advise if this applies in your area.
- Region C areas (64 m/s) are generally referred to as Cyclonic and are generally limited to northern coastal areas. Most Region C zones end 100km inland.
- Region D (79 m/s) is Australia's most extreme Cyclonic Region, located between the town of Carnarvon and Pardoo Station in Western Australia.

## Determine the Terrain Category

You will need to determine the terrain category to ensure the installation meets the required standard.

Terrain Category 1 (TC1) – Very exposed open terrain with few or no obstructions and enclosed, limited-sized water surfaces at serviceability and ultimate wind speeds in all wind regions, e.g. flat, treeless, poorly grassed plains; rivers, canals and lakes; and enclosed bays extending less than 10km in the wind direction.

Terrain Category 1.5 (TC1.5) – Open water surfaces subjected to shoaling waves at serviceability and ultimate wind speeds in all win regions, e.g. near-shore ocean water; larger unenclosed bays on seas and oceans; lakes; and enclosed bays extending greater than 10km in the wind direction. The terrain height multipliers for this terrain category shall be obtained by the linear interpolation between the values for the TC1 and TC2.

Terrain Category 2 (TC2) – Open terrain, including grassland, with well-scattered obstructions having heights generally from 1.5m to 5m, with no more than two obstructions per hectare, e.g. farmland and cleared subdivisions with isolated trees and uncut grass.

Terrain Category 2.5 (TC2.5) – Terrain with a few trees or isolated obstructions. This category is intermediate between TC2 and TC3 and represents the terrain in developing outer urban areas with scattered houses, or larger acreage developments with fewer than ten buildings per hectare. The terrain-height multipliers for this terrain category shall be obtained by linear interpolation between the values for the TC2 and TC3.

Terrain Category 3 (TC3) – Terrain with numerous closely spaced obstructions having heights generally from 3m to 10m. The minimum density of obstructions shall be at least the equivalent of 10 house sized obstructions per hectare, e.g. suburban housing or light industrial estates.

Terrain Category 4 (TC4) – Terrain with numerous larger, high (10m to 30m tall) and closely-spaced constructions buildings, such as large city centers and well-developed industrial complexes.

If your installation site is not at TC 2, 2.5 or 3, please contact Clenergy to obtain a project specific engineering certificate to support your installation.

## Verify Atmospheric Corrosivity Zone of Installation Site

Please refer to "AS 4312-2008 Atmospheric Corrosivity Zones in Australia" or consult local construction business to verify corrosivity category of installation site to determine appropriate products and interface spacing. When standard products are installed in high corrosivity zones, like C4/C5, interface spacing reduction factor need to be applied. Please refer to the generic notes of Certification Letter for the details.

Note: Clenergy provided screws for Tin interfaces are suitable for up to C3 corrosive environments only.

## Determine the Height of the Installation Site

This document provides sufficient information for the PV-ezRack® SolarRoof system installation up to heights of 30 meters. If your installation site is more than 30 meters high, please contact Clenergy to obtain project specific engineering certificate to support your installation.

### Determine Roof slope

The PV-ezRack® SolarRoof system can be used for roof slopes up to 60°. Please verify that the Installation site roof slope is between 0° and 60°.

### Determine the Installation Area of Roof

Please refer to the generic notes 29, 30 and 32 of Certification Letter to determine the installation area based on building height, length, and width. Please be aware at certain building conditions there is an Exclusion Zone for flush installation, which is the minimum distance between PV solar panel and roof edge of "2s", where "s" is the gap between the underside of the panel and the roof surface.

### Verify Rafter Properties of Building

Please verify rafter properties of building, which could affect the interface spacing.

Timber Rafters:

Tile Roof interface spacing tables are based on a minimum depth into F7 (Pine) timber of 25mm.

Metal Rafters:

Tile Roof interface spacing tables are based on 1.9mm thick Steel Purlins G450 or equivalent. For more information, please refer to Note 3 and 4 of the Certification Letter.

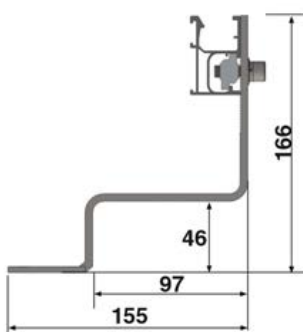

ER-I-01, ER-I-01/CS

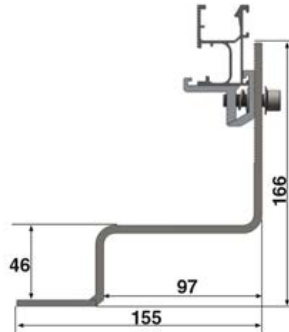

ER-I-01/EZC/ECO

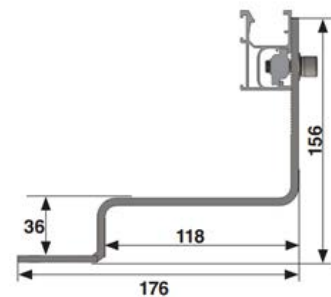

ER-I-51

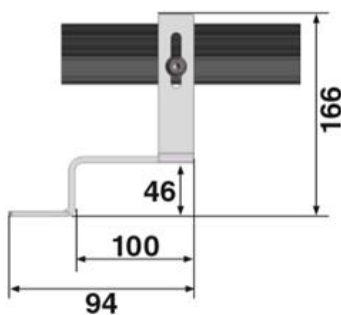

ER-I-23

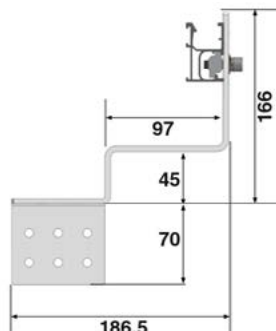

ER-I-26

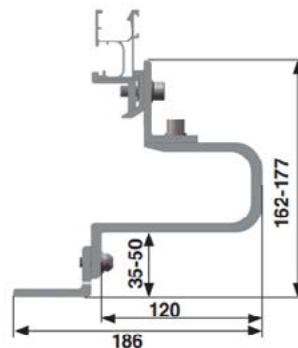

ER-I-41/EZC/ ECO

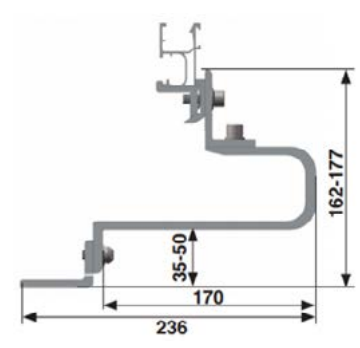

ER-I-61/EZC/ECO

### Determine the Maximum Rail Support Spacing

Please refer to the interface spacing tables in the Certification Letter appended in this document.

If a project specific Certification Letter has been provided, please refer to the support spacing in this letter.

### Verify Maximum Rail End Overhang

Rail end overhang should be not over 40% of the interface spacing. For example, if the interface spacing is 1500mm, the Rail end overhang can be up to 600mm only.

### Acquire PV Modules Clamping Zone Information

It is recommended to acquire PV modules clamping zone information from PV modules manufacturer, which can help to plan interface, and rail position and orientation.

### Assembly Drawing



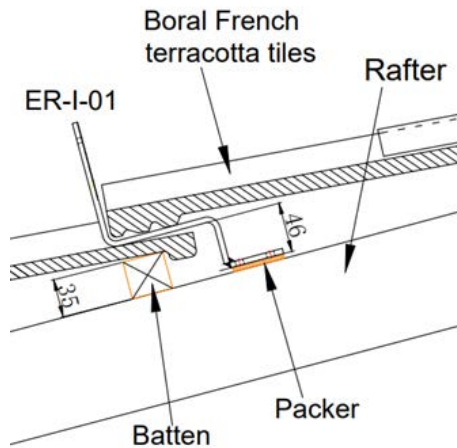



Please refer below for a case example of an assembly drawing of Clenergy Tile Bracket, ER-I-01, with Boral French Terracotta Tiles:



For more information, refer to Installation Instruction on page 10.

# Tools and Components



## Tools

				
<p>Angle Grinder with Stone Disk</p>	<p>Screw Driver (for M8 Hexagon Socket Screw)</p>	<p>Torque Spanner</p>	<p>Spanner</p>	<p>5m Tape</p>
 <p>String &amp; Marker Pen</p>				

## Components

				
<p>ER-EC-ST End Clamp</p>	<p>ER-IC-ST Inter Clamp</p>	<p>C-U/30/46-G Universal Clamp</p>	<p>C-U/30/46 Universal Clamp</p>	<p>ER-EC-DU35/40 End Clamp, Dual 35 or 40mm</p>
				
<p>ER-EC-DU40/46 End Clamp, Dual 40 or 46mm</p>	<p>ER-R-ECO ECO-Rail</p>	<p>ER-SP-ECO Splice for ECO-Rail</p>	<p>ER-I-01 Tile Interface</p>	<p>ER-I-01/CS Tile Interface, Carbon Steel</p>

## Components

				
<p><b>ER-I-01/EZC/ECO</b> Tile Interface with ezClick connection for ECO-Rail</p>	<p><b>ER-I-51</b> Tile Interface, 118mm horizontal arm</p>	<p><b>ER-I-23</b> Tile Interface-Landscape</p>	<p><b>ER-I-26</b> Tile Interface-Side mount</p>	<p><b>ER-I-41/EZC/ECO</b> Adjustable Tile Interface with ezclick connection, 120 mm horizontal arm</p>
				
<p><b>ER-I-61/EZC/ECO</b> Adjustable Tile Interface with ezclick connection, 170 mm horizontal arm</p>	<p><b>SCO-ECO/380</b> Side Channel Cover for Cutter-Rail, length 380 mm</p>	<p><b>EZ-RE-200</b> Roof Hook Extender</p>	<p><b>IS-SR265/111</b> Isolator Shade, non-assembly (Mill Finish)</p>	<p><b>AB-SR/IS/260</b> Angle Bracket</p>
				
<p><b>EZ-GL-ST</b> Grounding Lug</p>	<p><b>EZ-GC-ST</b> Grounding Clip</p>			



# System Overview

## Overview of PV-ezRack® SolarRoof Terracotta Tile

### Terracotta Tile

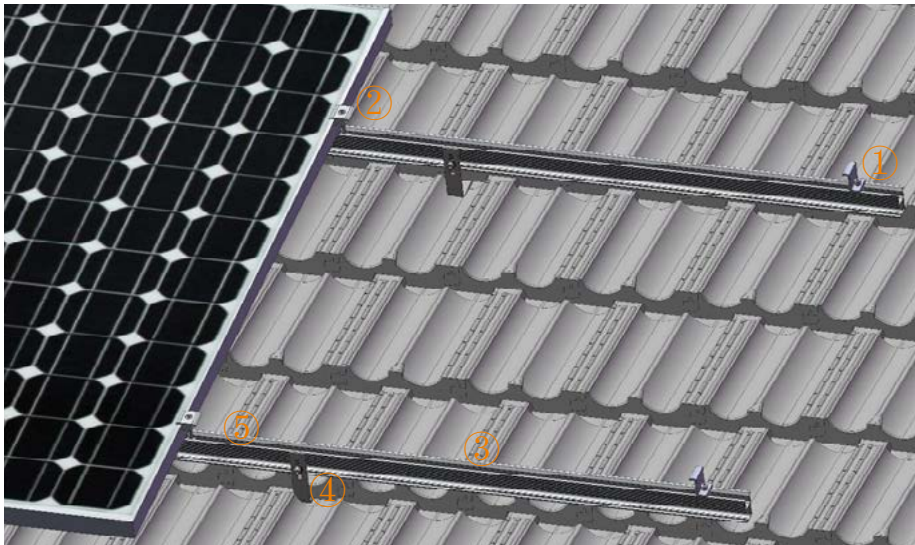

1. End Clamp    2. Inter Clamp    3. ECO-Rail    4. Tile interface    5. Splice for ECO-Rail

## Precautions during Stainless Steel Fastener Installation

Improper operation may lead to deadlock of Nuts and Bolts. The steps below should be applied to stainless steel nut and bolt assembly to reduce this risk.

### General installation instructions:

- (1) Apply force to fasteners in the direction of thread
- (2) Apply force uniformly, to maintain the required torque
- (3) Professional tools and tool belts are recommended
- (4) In some cases, fasteners could be seized over time. As an option, if want to avoid galling or seizing of thread, apply lubricant (grease or 40# engine oil) to fasteners prior to tightening.

### Safe Torques

Please refer to safe torques defined in this guide as shown in the figures below. When fixing mid and end clamps, if the torques range specified by the panel manufacturer is different, it should be used instead. In case power tools are required, Clenergy recommends the use of low speed only. High speed and impact drivers increase the risk of bolt galling (deadlock) If deadlock occurs and you need to cut fasteners, ensure that there is no load on the fastener before you cut it. Avoid damaging the anodized or galvanized surfaces.

## Installation Dimensions

All drawings and dimensions in this Installation Guide are a generic reference only. PV-ezRack® SolarRoof is to be optimized to suit specific conditions for each project and should be documented in a construction drawing.

Major components of PV-ezRack® SolarRoof may be provided in section sizes and lengths varying from those shown in this guide. The installation process detailed in this instruction guide remains the same regardless of changes in component size.

If you need to do any on-site modifications or alteration of the system please provide marked up drawings/sketches for Clenergy's review, prior to modification, for comment and approval.

# Installation Instructions

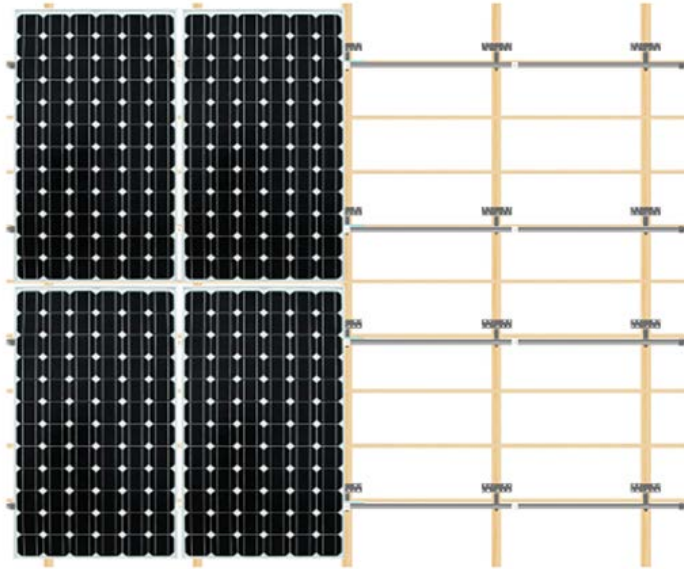

- Assess the number of modules in the vertical direction using the module height plus at least 18mm between modules (please check the installation manual of the solar module manufacturer).
- Assess the Number of modules in the horizontal direction using the module width plus 18 mm (20 mm if using Universal Clamps) between the modules. Note: The standard end clamp will also add 20 mm (except for dual end clamps) on each side to the space required.
- Assess the horizontal spacing of the Roof Hooks.
- Assess the vertical spacing of the Roof Hooks = approx.  $\frac{1}{2}$  to  $\frac{3}{4}$  of module height.
- Always check the installation manual of the PV-Module you use in order to determine the allowed fixing points on the module frame.

## Terracotta Tile Interface Installation

Determine the positions of the Roof Hooks according to your plans. Remove the roof tiles at the marked positions or, if possible, simply push them up slightly.

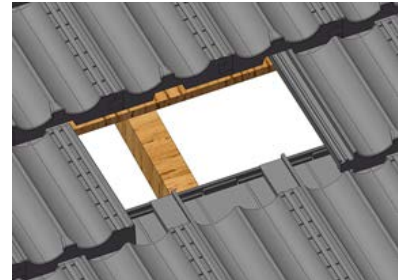

Fix the Roof Hooks to the rafter using Clenergy provided Buildex 14 gauge Hex Head Zips screw with minimum 25 mm embedment as shown in the figure on the right following the Buildex screws installation guide below:



- Use a 3/8" Hex Socket.
- Use a mains powered or cordless screw driver with a drive speed of 3,000 RPM maximum.
- Fit the driver bit into the screw and place at the fastening position.
- Apply consistently firm pressure (end load) to the screwdriver until the screw is fastened.

The roof hook must not press against the roof tile. If necessary, pack the roof hook with max pack height of 17 mm for Clenergy provided Buildex 50 mm long screw, with max pack height of 35 mm for Clenergy provided Buildex 65 mm long screw.

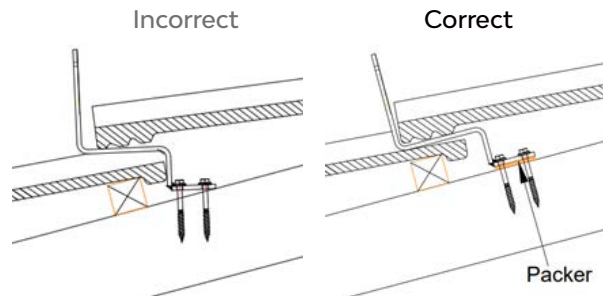

If necessary, use an angle grinder to cut a recess in the tile covering the Roof Hook at the point where the Roof Hook extends so that the tile lies flat on the surface. If grooved tiles are used, it will also be necessary to cut a recess in the lower tile.

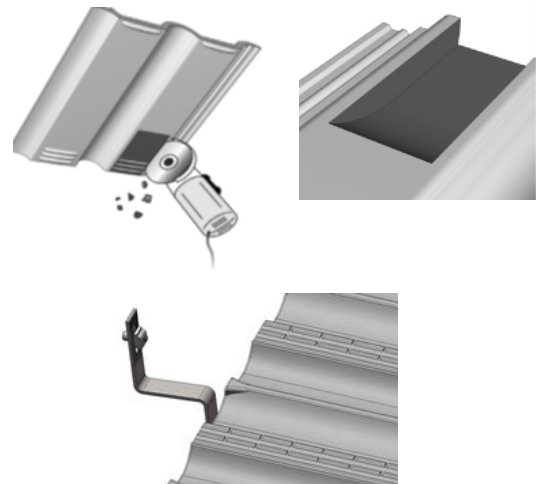

**Caution!**

Do not use fitted roof hooks as a ladder, as this extreme point load could damage the tile below.

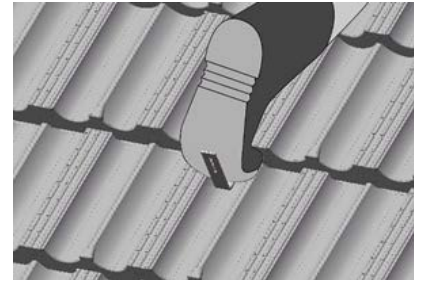

Variation for installation on plain tile roofs with plain tile roof cladding: A recess must be cut into the tiles around the position of the roof hook. The tile flashing should be used if necessary, to prevent ingress of water.

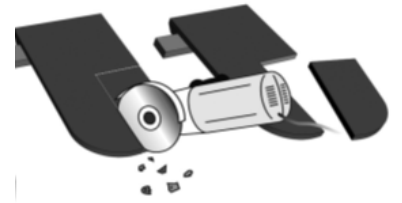

## Rail Installation

To connect several rails together, slide half of the splice into the rear side of the rail. Fasten the first M8 Bolt using an Allen key, and slide the next rail into the splice. Tighten the second M8 Bolt using an Allen key. The total rail length is recommended not to be over 30 meters considering rails thermal expansion problem. Splice provides the electrical connection between the 2 rails through the pressure bolts. This eliminates the need of using 2 earthing lugs. Recommended torque is 10 ~12 N.m.

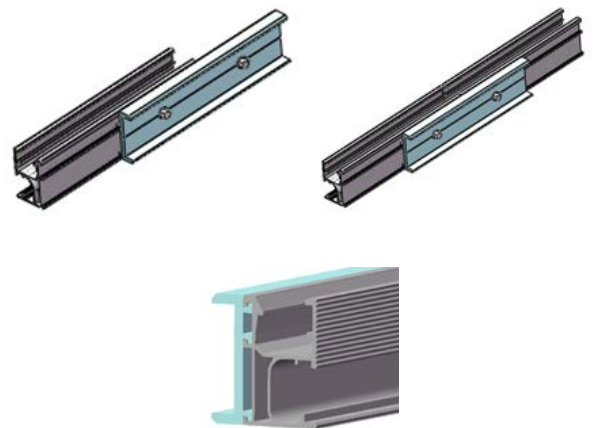

If the rails consist of different lengths, always begin with the shortest piece. Install the PV Rails on the Roof Hooks and fasten loosely with M8 x 25 bolt and washers as shown in the figure on the right. Two to three screw turns are adequate for loose installation.



ER-I-01

Adjust the vertical and horizontal positioning using the long hole in the Roof Hook and the loosely connected Z Module in the rail, as shown in the figure on the right. The roof hook should not protrude over the rail after the adjustment. The recommended torque is 16~20N·m.

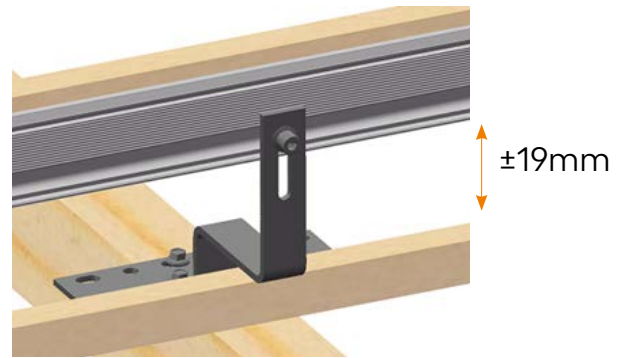

## PV Module Installation

### Deployment of Grounding Clips

1) When there is an even number of PV Module in each row: Install the grounding clips at the positions marked X in the figure shown. Then the number of Grounding Clips = number of PV Module. Eg; 4 grounding clips in the figure shown.

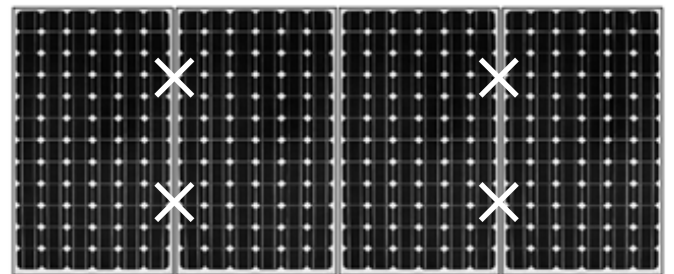

2) When there is an odd number of PV Module in each row: Install grounding clips at positions marked X in figure shown. Then the number of Grounding Clips = number of PV Module +1. Eg; 6 grounding clips in figure shown.

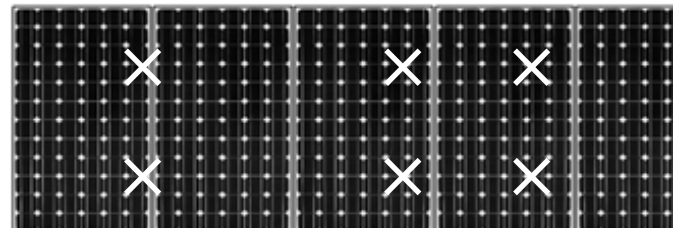

### Important Notes:

- When replacing defective PV Modules, it is required to replace the grounding clips under the defective PV Modules.
- When removing defective PV Modules, it is required to keep sufficient grounding clips to maintain all other PV modules' earthing continuity with the rail. It is required to install grounding clips under end clamps when necessary to achieve this.

Before installing the PV modules on horizontal rail installations, add anti-slip protection to the lowest row of PV modules. To do this, fasten M6 x 20 mm bolts (with the shank downwards) to the lower mounting holes of the PV module frame. When installing large modules (e.g. ASE250) M8 x 20 mm bolts must be used.

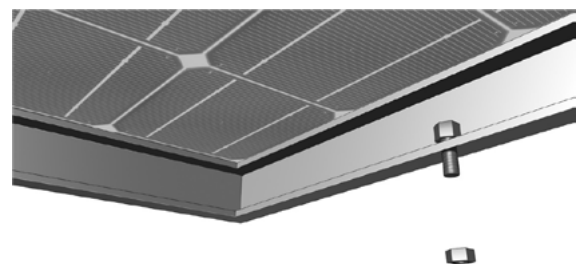

Place the PV Modules on to the rails and fix with End Clamps, Inter Clamps or Universal Clamps. Fasten with the Allen key. Please use Solution 1 or 2 below according to your project.

### Solution 1 (Apply Standard Clamps)

**Step 1:**

Place the first PV Module on the Rail according to your plan and fix it in place using the End Clamps. Then fasten lightly with the Allen Key as shown in the figure on the right.



**Step 2:**

Slightly lift the PV Module and slide Inter Clamps and Grounding Clips into position. The teeth on Grounding Clip will automatically align when the Inter Clamp is properly installed as shown in the figure on the right.

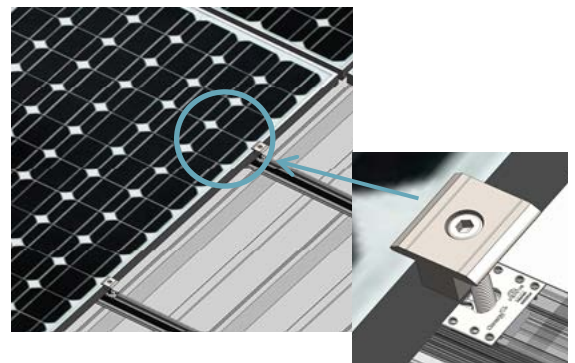

**Step 3:**

loosely place the next framed PV Module into the other side of the Inter Clamp and Grounding Clip as shown in the figure on the right.

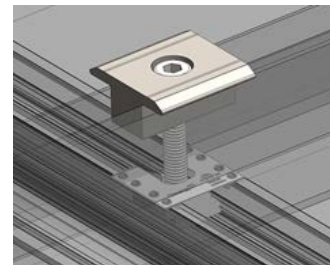

**Important Notes:**

-To fix the Grounding Clip properly, ensure the frames of PV Modules are completely pressed against the Inter Clamps and Grounding Clips. Visually check that Grounding Clips are positioned properly.

-Grounding Clips are intended for SINGLE USE ONLY! Only fasten the bolts down when the position of the PV Module is finalized. (Only slightly tighten bolts to keep PV Modules in place prior to the final check)

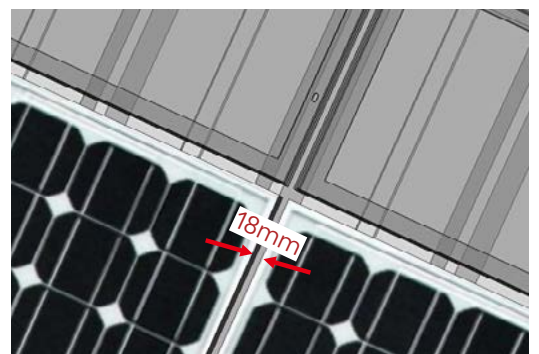

## Solution 2 (Apply Universal Clamps)

### Step 1:

Twisting the head of the Universal Clamp changes the functionality from End to Inter Clamp as shown in the figure on the right. NOTE: Please ensure the Universal Clamp C-U/30/46 or Universal Clamp with Grounding Clip C-U/30/46-G is positioned correctly according to "Deployment of Grounding Clips" (P13).

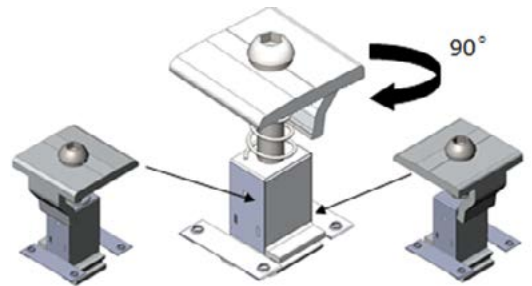

### Step 2:

Incline the Universal Clamp to fit the lower channel against the lower channel of the Rail and press the Universal Clamp down towards the other side to securely fit the upper channel against the upper rail channel, as shown in the figure on the right.

### Note:

Before installation, make sure there is enough clearance between the screw and lower module of Universal Clamp as shown in the figure on the right.

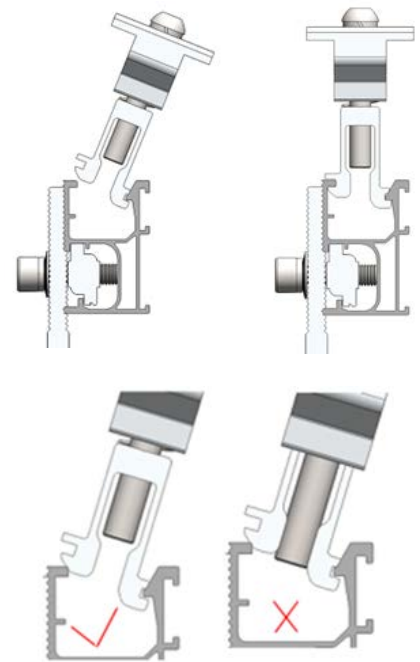

### Step 3:

Place the first PV Module on the Rails and apply the Universal Clamp in the End Clamp position and fasten slightly with the Allen Key. Make sure the frame of the PV Module is fully in contact with the Universal Clamp as shown in the figure on the right. Visually check the Universal Clamp and PV module are properly installed.

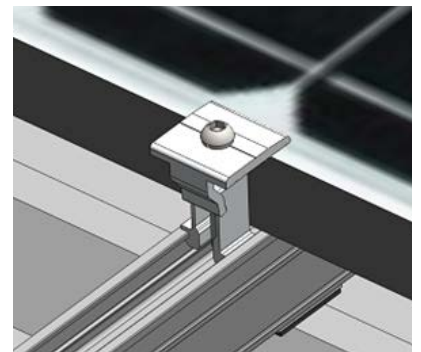



**Step 4:**

When using as an Inter Clamp, click the Universal Clamp into the rail channel and slightly lift the framed PV Module to ensure the Grounding Clip is fully covered as shown in the figure on the right.



**Step 5:**

Loosely place the next framed PV Module into the other side of the Universal Clamp. Ensure the Grounding Clip is fully covered and ensure the frame of the PV Module is in close contact with Universal Clamp as shown in the figure on the right.



**Step 6:**

Repeat steps above to install all PV Modules. Visually check the Universal Clamps and PV modules are properly positioned and then fasten all Clamps.

When you are using Universal Clamps, the gap between two adjacent PV Modules is 20mm. The recommend torque for Universal Clamps in the End Clamp position is 13~14N·m. The recommend torque for Universal Clamps in the Inter Clamp position is 16~20N·m.

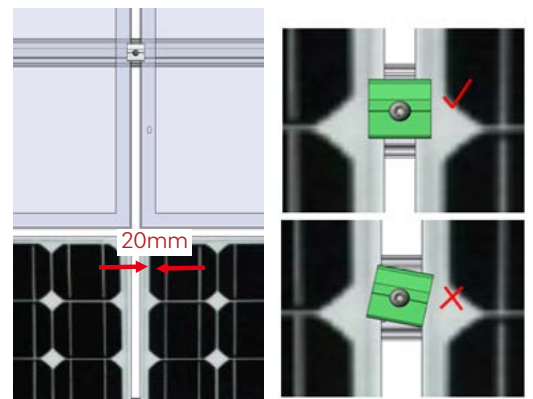
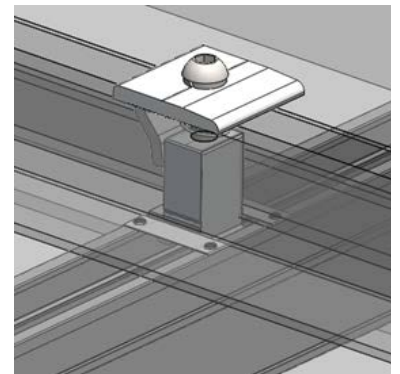

Apply one pre-assembled Grounding Lug per Rail. Slide the Grounding Lug into to the rail channel and fasten the bolt M8\*25 with 16~20 N·m. Strip earthing cable (the maximum size is 10 mm<sup>2</sup> ) and insert the conductor into the provided copper tube. Place the copper tube into the channel of Grounding Lug and tighten M6\*10 with 5-6 N·m to ensure the earthing cable is tight.

**Note:**

Check the electrical resistance between rail and earthing cable conductor to ensure the bonding is made.

There are three solutions for Grounding Lug installation:

**Solution 1**

Fix the Grounding Lug into the top channel of Rail as shown in the figure on the right.

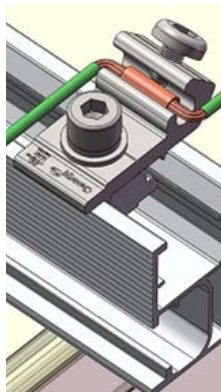

**Solution 2**

Fix the Grounding Lug into the top channel of Rail where just under the PV Module as shown in the figure on the right.

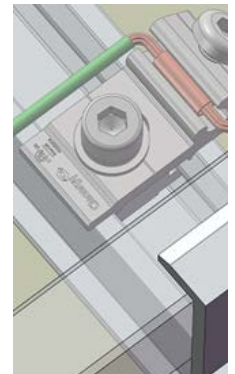

**Solution 3**

Fix the Grounding Lug at the side channel of Rail as shown in the figure on the right.



Slide the first PV module of the second row onto the corresponding module of the first row. Separation from the lower PV module can be maintained for aesthetic reasons. An Inter Clamp can be used as a separator, so that the vertical and horizontal separation of the PV modules is identical. Continue mounting the modules as described in steps on P13 to P17 until all PV modules are installed.

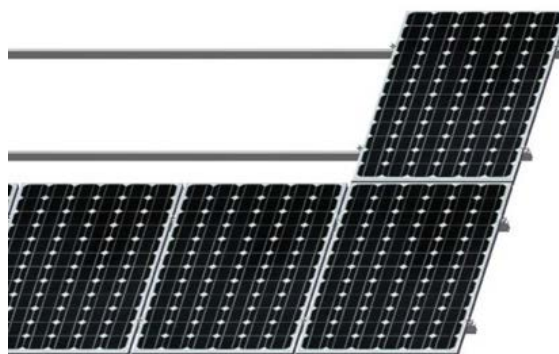

# Certification



**CIVIL & STRUCTURAL ENGINEERS**  
RESIDENTIAL - INDUSTRIAL - COMMERCIAL - PRODUCT DEVELOPMENT

info@mwengineering.melbourne  
Phone: 1300 MWENG-0 (1300 69364-0)  
www.mwengineering.melbourne  
ABN 37 605 815 585

20 October 2020

Clenergy Australia  
1/10 Duerdin Street  
Clayton, VIC 3168

## CERTIFICATION LETTER

Clenergy PV-ezRack Solar Roof Certification – TC2, 2.5, 3 – Wind Region A, B, C, D. Internal REF: **00115**.  
Project REF: **CL-10088-SM-REV-H**.

MW Engineering Melbourne, being Structural Engineers within the meaning of Australian regulations, have calculated the maximum spacings for the PV ez-Rack rail system for the following conditions:

- **Wind Loads to AS 1170.2-2011 AMDT 4-2016**
  - o **Wind Terrain Category 2, 2.5 and 3**
  - o **Wind average recurrence of 200 years**
  - o **Wind Region A, B, C, D**
- **Solar panel length up to 2.2m**
- **Solar panel width up to 1.2m**

Attached are the tables showing the spacings according to Wind Region, roof pitch, and building height.

The values shown on these tables will be valid unless an amendment is issued on any of the following codes:

- |                                   |                    |
|-----------------------------------|--------------------|
| - AS/NZS 1170.0- 2002 AMDT 4-2016 | General Principles |
| - AS/NZS 1170.1- 2002 AMDT 4-2016 | Imposed Loadings   |
| - AS/NZS 1170.2- 2011 AMDT 4-2016 | Wind Loadings      |
| - AS/NZS 1664.1- 1997 AMDT 1:1999 | Aluminium Code     |

Should you have any queries, do not hesitate to contact us.

Best Regards,



Alberto Escobar  
Civil/Structural Engineer  
**BEng MIEAust NER**  
BRP EC 46542  
RPEQ 18759  
[info@mwengineering.melbourne](mailto:info@mwengineering.melbourne)

October 2020



## **STRUCTURAL DESIGN CERTIFICATION**

# **PV-ezRack<sup>R</sup> SolarRoof tin and tile flush interface spacing tables according to AS/NZS 1170.2:2011 Amdt 4-2016 Within Australia Terrain Category 2, 2.5 & 3**

**Client: Clenergy Australia**

**REF: CL-10088-SM – REV H**

**Date: OCT 2020**

**Copyright:** The concepts and information contained in this document are the property of MW Engineering Melbourne. Use or copying of this document in whole or in part without the written permission of MW Engineering Melbourne constitutes an infringement in copyright.

**Limitation:** This report has been prepared for the exclusive use of Clenergy Australia, and is subject to and issued in connection with the provisions of the agreement between MW Engineering Melbourne and Clenergy Australia. MW Engineering Melbourne accepts no liability or responsibility whatsoever for any use of or reliance upon this report by any third party other than Clenergy's clients.



**Internal REF: 00115**

**Client: Clenergy Australia**

**Project: PV-ezRack SolarRoof tin and tile flush interface spacing tables**

**Australian Standards**

**AS/NZS 1170.0:2002 (R2016)**

**AS/NZS 1170.1:2002 (R2016)**

**AS/NZS 1170.2:2011 (R2016)**

**AS/NZS 1664.1:1997-Amdt 1:1999**

**General Principles**

**Imposed loadings**

**Wind Loadings**

**Aluminium**

**Wind Terrain Category: 2, 2.5 & 3**

**Wind average recurrence: 200 years**

**Designed: SM**

**Date: OCT 2020**

**Disclaimer: From the date of publication onwards, any amendment made to any of the above-mentioned Standards will make this report outdated and a new one will have to be released, unless the amendment has no implications on this certificate.**

**Contents**

ER-I-01 - T.C 2 ..... 4

ER-I-01 - T.C 2.5 ..... 6

ER-I-01 - T.C 3 ..... 8

ER-I-05 - T.C 2 ..... 10

ER-I-05 - T.C 2.5 ..... 12

ER-I-05 - T.C 3 ..... 14

**General Notes** ..... 16

Standard screws shipped for tin and tile roof interfaces ..... 16

Tin and tile reduction factors table for 0.75 mm thick steel battens and 1.2mm thick purlins ..... 16

Tin increase factors table for 1.9 mm and 2.4 mm thick purlins ..... 16

Timber batten embedment reduction factors table ..... 16

Components table ..... 17

Panel size reduction/increasing factors table ..... 20

Tile interface reduction factors table ..... 21

## PV-ezRack SolarRoof Interface spacing tables

Type of Rail	ER-R-ECO (Refer to <a href="#">Note 7</a> for other compatible rails)
Type of Interface	ER-I-01 (Tile Interface)
Solar Panel Dimension	2 m x 1 m (Refer to <a href="#">Note 13</a> for other panel sizes)
Terrain Category	2

### Roof Angle - $0^\circ < \alpha \leq 10^\circ$

Wind Region	Building Height (m)									
	$H \leq 5$		$5 < H \leq 10$		$10 < H \leq 15$		$15 < H \leq 20$		$20 < H \leq 30$	
	U.W & D.W	Central	U.W & D.W	Central	U.W & D.W	Central	U.W & D.W	Central	U.W & D.W	Central
A	1488	1637	1444	1588	1369	1506	1354	1490	1310	1441
B	1086	1195	997	1097	893	982	819	900	700	769
C	692	761	647	712	566	622	513	565	454	499
D	417	458	402	442	365	401	327	360	290	319

### Roof Angle - $10^\circ < \alpha \leq 20^\circ$

Wind Region	Building Height (m)									
	$H \leq 5$		$5 < H \leq 10$		$10 < H \leq 15$		$15 < H \leq 20$		$20 < H \leq 30$	
	U.W & D.W	Central	U.W & D.W	Central	U.W & D.W	Central	U.W & D.W	Central	U.W & D.W	Central
A	1459	1604	1415	1556	1342	1476	1327	1460	1284	1412
B	1065	1171	977	1075	875	963	802	882	686	754
C	678	746	634	698	554	610	503	554	445	489
D	408	449	394	433	357	393	321	353	284	313

### Roof Angle - $20^\circ < \alpha \leq 30^\circ$

Wind Region	Building Height (m)									
	$H \leq 5$		$5 < H \leq 10$		$10 < H \leq 15$		$15 < H \leq 20$		$20 < H \leq 30$	
	U.W & D.W	Central	U.W & D.W	Central	U.W & D.W	Central	U.W & D.W	Central	U.W & D.W	Central
A	1444	1588	1400	1540	1328	1461	1314	1445	1270	1397
B	1054	1159	967	1064	866	953	794	873	679	746
C	671	738	628	691	549	603	498	548	440	484
D	404	445	390	429	354	389	318	349	282	310

## PV-ezRack SolarRoof Interface spacing tables (Cont.)

Type of Rail	ER-R-ECO (Refer to <a href="#">Note 7</a> for other compatible rails)
Type of Interface	ER-I-01 (Tile Interface)
Solar Panel Dimension	2 m x 1 m (Refer to <a href="#">Note 13</a> for other panel sizes)
Terrain Category	2

### Roof Angle - $30^\circ < \alpha \leq 60^\circ$

Wind Region	Building Height (m)									
	H ≤ 5		5 < H ≤ 10		10 < H ≤ 15		15 < H ≤ 20		20 < H ≤ 30	
	U.W & D.W	Central	U.W & D.W	Central	U.W & D.W	Central	U.W & D.W	Central	U.W & D.W	Central
A	1414	1555	1371	1509	1301	1431	1287	1415	1244	1369
B	1032	1135	947	1042	848	933	778	855	665	731
C	657	723	615	677	537	591	488	537	431	474
D	396	435	382	420	346	381	311	342	276	303



## PV-ezRack SolarRoof Interface spacing tables

Type of Rail	ER-R-ECO (Refer to <a href="#">Note 7</a> for other compatible rails)
Type of Interface	ER-I-01 (Tile Interface)
Solar Panel Dimension	2 m x 1 m (Refer to <a href="#">Note 13</a> for other panel sizes)
Terrain Category	2.5

### Roof Angle - $0^\circ < \alpha \leq 10^\circ$

Wind Region	Building Height (m)									
	H ≤ 5		5 < H ≤ 10		10 < H ≤ 15		15 < H ≤ 20		20 < H ≤ 30	
	U.W & D.W	Central	U.W & D.W	Central	U.W & D.W	Central	U.W & D.W	Central	U.W & D.W	Central
A	1560	1717	1514	1665	1436	1579	1420	1562	1373	1511
B	1139	1253	1046	1150	936	1030	858	944	733	807
C	726	798	679	747	593	652	538	592	476	524
D	437	481	421	463	382	421	343	378	304	335

### Roof Angle - $10^\circ < \alpha \leq 20^\circ$

Wind Region	Building Height (m)									
	H ≤ 5		5 < H ≤ 10		10 < H ≤ 15		15 < H ≤ 20		20 < H ≤ 30	
	U.W & D.W	Central	U.W & D.W	Central	U.W & D.W	Central	U.W & D.W	Central	U.W & D.W	Central
A	1529	1682	1483	1632	1407	1548	1392	1531	1346	1480
B	1116	1228	1025	1127	918	1009	841	925	719	791
C	711	782	665	732	581	639	528	580	466	513
D	428	471	413	454	375	412	336	370	298	328

### Roof Angle - $20^\circ < \alpha \leq 30^\circ$

Wind Region	Building Height (m)									
	H ≤ 5		5 < H ≤ 10		10 < H ≤ 15		15 < H ≤ 20		20 < H ≤ 30	
	U.W & D.W	Central	U.W & D.W	Central	U.W & D.W	Central	U.W & D.W	Central	U.W & D.W	Central
A	1514	1665	1468	1615	1393	1532	1377	1515	1332	1465
B	1105	1215	1014	1116	908	999	833	916	711	783
C	704	774	658	724	575	633	522	574	462	508
D	424	466	409	450	371	408	333	366	295	325

## PV-ezRack SolarRoof Interface spacing tables (Cont.)

Type of Rail	ER-R-ECO (Refer to <a href="#">Note 7</a> for other compatible rails)
Type of Interface	ER-I-01 (Tile Interface)
Solar Panel Dimension	2 m x 1 m (Refer to <a href="#">Note 13</a> for other panel sizes)
Terrain Category	2.5

### Roof Angle - $30^\circ < \alpha \leq 60^\circ$

Wind Region	Building Height (m)									
	$H \leq 5$		$5 < H \leq 10$		$10 < H \leq 15$		$15 < H \leq 20$		$20 < H \leq 30$	
	U.W & D.W	Central	U.W & D.W	Central	U.W & D.W	Central	U.W & D.W	Central	U.W & D.W	Central
A	1482	1631	1438	1582	1364	1500	1349	1484	1305	1435
B	1082	1190	993	1093	889	978	815	897	697	766
C	689	758	645	709	563	620	511	563	452	497
D	415	457	400	440	363	400	326	359	289	318

## PV-ezRack SolarRoof Interface spacing tables

Type of Rail	ER-R-ECO (Refer to <a href="#">Note 7</a> for other compatible rails)
Type of Interface	ER-I-01 (Tile Interface)
Solar Panel Dimension	2 m x 1 m (Refer to <a href="#">Note 13</a> for other panel sizes)
Terrain Category	3

### Roof Angle - $0^\circ < \alpha \leq 10^\circ$

Wind Region	Building Height (m)									
	$H \leq 5$		$5 < H \leq 10$		$10 < H \leq 15$		$15 < H \leq 20$		$20 < H \leq 30$	
	U.W & D.W	Central	U.W & D.W	Central	U.W & D.W	Central	U.W & D.W	Central	U.W & D.W	Central
A	1665	1832	1615	1777	1532	1685	1515	1667	1465	1612
B	1216	1337	1116	1227	999	1099	916	1008	783	861
C	774	852	724	797	633	696	575	632	508	559
D	466	513	450	495	408	449	366	403	325	357

### Roof Angle - $10^\circ < \alpha \leq 20^\circ$

Wind Region	Building Height (m)									
	$H \leq 5$		$5 < H \leq 10$		$10 < H \leq 15$		$15 < H \leq 20$		$20 < H \leq 30$	
	U.W & D.W	Central	U.W & D.W	Central	U.W & D.W	Central	U.W & D.W	Central	U.W & D.W	Central
A	1632	1795	1583	1741	1501	1652	1485	1634	1436	1580
B	1191	1311	1093	1203	979	1077	898	987	767	844
C	759	835	710	781	620	682	563	619	498	548
D	457	503	441	485	400	440	359	395	318	350

### Roof Angle - $20^\circ < \alpha \leq 30^\circ$

Wind Region	Building Height (m)									
	$H \leq 5$		$5 < H \leq 10$		$10 < H \leq 15$		$15 < H \leq 20$		$20 < H \leq 30$	
	U.W & D.W	Central	U.W & D.W	Central	U.W & D.W	Central	U.W & D.W	Central	U.W & D.W	Central
A	1615	1777	1567	1724	1486	1635	1470	1617	1422	1564
B	1179	1297	1082	1191	969	1066	888	977	759	835
C	751	826	703	773	614	675	557	613	493	542
D	452	498	436	480	396	435	355	391	315	346

## PV-ezRack SolarRoof Interface spacing tables (Cont.)

Type of Rail	ER-R-ECO (Refer to <a href="#">Note 7</a> for other compatible rails)
Type of Interface	ER-I-01 (Tile Interface)
Solar Panel Dimension	2 m x 1 m (Refer to <a href="#">Note 13</a> for other panel sizes)
Terrain Category	3

### Roof Angle - $30^\circ < \alpha \leq 60^\circ$

Wind Region	Building Height (m)									
	$H \leq 5$		$5 < H \leq 10$		$10 < H \leq 15$		$15 < H \leq 20$		$20 < H \leq 30$	
	U.W & D.W	Central	U.W & D.W	Central	U.W & D.W	Central	U.W & D.W	Central	U.W & D.W	Central
A	1582	1740	1535	1688	1455	1601	1440	1584	1392	1531
B	1155	1270	1060	1166	949	1044	870	957	744	818
C	736	809	688	757	601	661	546	600	483	531
D	443	487	427	470	388	426	348	383	308	339

## PV-ezRack SolarRoof Interface spacing tables

Type of Rail	ER-R-ECO (Refer to <a href="#">Note 7</a> for other compatible rails)
Type of Interface	ER-I-05 (Tin Interface)
Solar Panel Dimension	2 m x 1 m (Refer to <a href="#">Note 13</a> for other panel sizes)
Terrain Category	2

### Roof Angle - $0^\circ < \alpha \leq 10^\circ$

Wind Region	Building Height (m)									
	H ≤ 5		5 < H ≤ 10		10 < H ≤ 15		15 < H ≤ 20		20 < H ≤ 30	
	U.W & D.W	Central	U.W & D.W	Central	U.W & D.W	Central	U.W & D.W	Central	U.W & D.W	Central
A	1579	1737	1496	1646	1469	1616	1432	1575	1377	1515
B	1368	1505	1157	1272	1047	1151	964	1060	900	990
C	890	980	734	808	670	737	624	687	588	646
D	542	596	506	556	431	475	395	434	367	404

### Roof Angle - $10^\circ < \alpha \leq 20^\circ$

Wind Region	Building Height (m)									
	H ≤ 5		5 < H ≤ 10		10 < H ≤ 15		15 < H ≤ 20		20 < H ≤ 30	
	U.W & D.W	Central	U.W & D.W	Central	U.W & D.W	Central	U.W & D.W	Central	U.W & D.W	Central
A	1574	1732	1492	1641	1460	1606	1423	1565	1372	1510
B	1359	1495	1157	1272	1042	1146	955	1050	895	985
C	881	969	730	803	661	727	620	682	583	641
D	532	586	464	510	422	465	386	424	358	394

### Roof Angle - $20^\circ < \alpha \leq 30^\circ$

Wind Region	Building Height (m)									
	H ≤ 5		5 < H ≤ 10		10 < H ≤ 15		15 < H ≤ 20		20 < H ≤ 30	
	U.W & D.W	Central	U.W & D.W	Central	U.W & D.W	Central	U.W & D.W	Central	U.W & D.W	Central
A	1570	1727	1487	1636	1460	1606	1418	1560	1368	1505
B	1359	1495	1148	1262	1037	1141	950	1045	890	980
C	877	964	725	798	661	727	620	682	583	641
D	532	586	464	510	422	465	386	424	353	389

## PV-ezRack SolarRoof Interface spacing tables (Cont.)

Type of Rail	ER-R-ECO (Refer to <a href="#">Note 7</a> for other compatible rails)
Type of Interface	ER-I-05 (Tin Interface)
Solar Panel Dimension	2 m x 1 m (Refer to <a href="#">Note 13</a> for other panel sizes)
Terrain Category	2

### Roof Angle - $30^\circ < \alpha \leq 60^\circ$

Wind Region	Building Height (m)									
	$H \leq 5$		$5 < H \leq 10$		$10 < H \leq 15$		$15 < H \leq 20$		$20 < H \leq 30$	
	U.W & D.W	Central	U.W & D.W	Central	U.W & D.W	Central	U.W & D.W	Central	U.W & D.W	Central
A	1561	1717	1469	1616	1423	1565	1386	1525	1359	1495
B	1331	1464	1102	1212	1010	1111	936	1030	872	959
C	863	949	707	778	597	656	615	677	578	636
D	532	586	459	505	413	454	376	414	349	384

## PV-ezRack SolarRoof Interface spacing tables

Type of Rail	ER-R-ECO (Refer to <a href="#">Note 7</a> for other compatible rails)
Type of Interface	ER-I-05 (Tin Interface)
Solar Panel Dimension	2 m x 1 m (Refer to <a href="#">Note 13</a> for other panel sizes)
Terrain Category	2.5

### Roof Angle - $0^\circ < \alpha \leq 10^\circ$

Wind Region	Building Height (m)									
	$H \leq 5$		$5 < H \leq 10$		$10 < H \leq 15$		$15 < H \leq 20$		$20 < H \leq 30$	
	U.W & D.W	Central	U.W & D.W	Central	U.W & D.W	Central	U.W & D.W	Central	U.W & D.W	Central
A	1671	1838	1616	1777	1561	1717	1487	1636	1469	1616
B	1460	1606	1359	1495	1221	1343	1111	1222	1010	1111
C	1001	1101	890	980	789	868	725	798	652	717
D	624	687	569	626	505	555	459	505	422	465

### Roof Angle - $10^\circ < \alpha \leq 20^\circ$

Wind Region	Building Height (m)									
	$H \leq 5$		$5 < H \leq 10$		$10 < H \leq 15$		$15 < H \leq 20$		$20 < H \leq 30$	
	U.W & D.W	Central	U.W & D.W	Central	U.W & D.W	Central	U.W & D.W	Central	U.W & D.W	Central
A	1666	1833	1611	1772	1551	1707	1478	1626	1460	1606
B	1450	1595	1359	1495	1216	1338	1106	1217	1005	1106
C	996	1096	881	969	780	858	725	798	643	707
D	620	682	565	621	500	550	450	495	418	459

### Roof Angle - $20^\circ < \alpha \leq 30^\circ$

Wind Region	Building Height (m)									
	$H \leq 5$		$5 < H \leq 10$		$10 < H \leq 15$		$15 < H \leq 20$		$20 < H \leq 30$	
	U.W & D.W	Central	U.W & D.W	Central	U.W & D.W	Central	U.W & D.W	Central	U.W & D.W	Central
A	1662	1828	1607	1767	1551	1707	1473	1621	1455	1601
B	1450	1595	1354	1489	1212	1333	1102	1212	1001	1101
C	987	1086	877	964	776	853	721	793	643	707
D	620	682	565	621	496	545	454	500	413	454

## PV-ezRack SolarRoof Interface spacing tables (Cont.)

Type of Rail	ER-R-ECO (Refer to <a href="#">Note 7</a> for other compatible rails)
Type of Interface	ER-I-05 (Tin Interface)
Solar Panel Dimension	2 m x 1 m (Refer to <a href="#">Note 13</a> for other panel sizes)
Terrain Category	2.5

### Roof Angle - $30^\circ < \alpha \leq 60^\circ$

Wind Region	Building Height (m)									
	$H \leq 5$		$5 < H \leq 10$		$10 < H \leq 15$		$15 < H \leq 20$		$20 < H \leq 30$	
	U.W & D.W	Central	U.W & D.W	Central	U.W & D.W	Central	U.W & D.W	Central	U.W & D.W	Central
A	1652	1818	1561	1717	1515	1666	1469	1616	1359	1495
B	1395	1535	1304	1434	1193	1313	1092	1202	964	1060
C	955	1050	863	949	771	848	716	788	643	707
D	615	677	551	606	487	535	441	485	404	444



## PV-ezRack SolarRoof Interface spacing tables

Type of Rail	ER-R-ECO (Refer to <a href="#">Note 7</a> for other compatible rails)
Type of Interface	ER-I-05 (Tin Interface)
Solar Panel Dimension	2 m x 1 m (Refer to <a href="#">Note 13</a> for other panel sizes)
Terrain Category	3

### Roof Angle - $0^\circ < \alpha \leq 10^\circ$

Wind Region	Building Height (m)									
	H ≤ 5		5 < H ≤ 10		10 < H ≤ 15		15 < H ≤ 20		20 < H ≤ 30	
	U.W & D.W	Central	U.W & D.W	Central	U.W & D.W	Central	U.W & D.W	Central	U.W & D.W	Central
A	1744	1919	1735	1909	1671	1838	1597	1757	1450	1595
B	1528	1681	1524	1676	1423	1565	1285	1414	1148	1262
C	1102	1212	1092	1202	946	1040	845	929	753	828
D	689	757	679	747	606	666	532	586	468	515

### Roof Angle - $10^\circ < \alpha \leq 20^\circ$

Wind Region	Building Height (m)									
	H ≤ 5		5 < H ≤ 10		10 < H ≤ 15		15 < H ≤ 20		20 < H ≤ 30	
	U.W & D.W	Central	U.W & D.W	Central	U.W & D.W	Central	U.W & D.W	Central	U.W & D.W	Central
A	1735	1909	1726	1898	1666	1833	1588	1747	1446	1590
B	1524	1676	1519	1671	1418	1560	1276	1404	1138	1252
C	1102	1212	1088	1197	936	1030	840	924	748	823
D	684	752	670	737	601	661	523	576	464	510

### Roof Angle - $20^\circ < \alpha \leq 30^\circ$

Wind Region	Building Height (m)									
	H ≤ 5		5 < H ≤ 10		10 < H ≤ 15		15 < H ≤ 20		20 < H ≤ 30	
	U.W & D.W	Central	U.W & D.W	Central	U.W & D.W	Central	U.W & D.W	Central	U.W & D.W	Central
A	1680	1848	1662	1828	1597	1757	1524	1676	1377	1515
B	1515	1666	1423	1565	1368	1505	1248	1373	1102	1212
C	1203	1323	1065	1171	918	1010	826	909	725	798
D	776	853	652	717	588	646	514	565	450	495

## PV-ezRack SolarRoof Interface spacing tables (Cont.)

Type of Rail	ER-R-ECO (Refer to <a href="#">Note 7</a> for other compatible rails)
Type of Interface	ER-I-05 (Tin Interface)
Solar Panel Dimension	2 m x 1 m (Refer to <a href="#">Note 13</a> for other panel sizes)
Terrain Category	3

### Roof Angle - $30^\circ < \alpha \leq 60^\circ$

Wind Region	Building Height (m)									
	$H \leq 5$		$5 < H \leq 10$		$10 < H \leq 15$		$15 < H \leq 20$		$20 < H \leq 30$	
	U.W & D.W	Central	U.W & D.W	Central	U.W & D.W	Central	U.W & D.W	Central	U.W & D.W	Central
A	1671	1838	1662	1828	1597	1757	1524	1676	1377	1515
B	1441	1585	1423	1565	1368	1505	1248	1373	1102	1212
C	1074	1181	1065	1171	918	1010	826	909	725	798
D	661	727	652	717	588	646	514	565	450	495

**General Notes**

**Note 1.** Tile Roof Interface Spacing tables based on a minimum depth into F7 (Pine) timber of 25mm and Tin Roof Interface Spacing tables based on a minimum depth into F7 (Pine) timber of 35mm and Steel Purlins G450 1.5mm thick.

**Note 2.** Standard screws shipped for tin and tile Roof Interfaces

Metal Purlins/Battens	Fasteners to use
0.75 mm	Buildex- 14 - 11 x 70 Hex Head Zips Climaseal 3 with 16 mm ABW on G550 Steel Battens
1.5 mm - 2.4 mm	Buildex- 14 - 11 x 70 Hex Head Zips Climaseal 3 with 16 mm ABW
Wood Purlins and Rafters	Fasteners to be used
Timber F7 (Pine) and Timber 17 (Hardwood).	<b>Tin Interface:</b> Buildex- 14 - 11 x 70 Hex Head Zips Climaseal 3 with 16 mm ABW or 14g (6.3 mm)
	<b>Tile Interface:</b> Buildex- 14 - 11 x 70 Hex Head Zips Climaseal 3 with 16 mm ABW or 14-10 x 50 Hex Head T17 with 16mm ABW Climaseal 3 or 14-10 x 65 Hex Head T17 Climaseal 3 or other screw of pullout value not less than screws above.

**Note 3.** Tin and tile spacings were calculated based on Steel Purlins G450 1.5mm and Timber F7 (Pine). For 0.75 mm thick steel battens and 1.2mm thick purlins, all the fixing spacings shall be reduced as follows:

Wind Region A	Wind Region B	Wind Region C	Wind Region D
- 28 %	- 40 %	- 40 %	- 40 %

**Note 4.** For 1.9 mm and 2.4 mm thick purlins, all the fixing spacings shall be increased as follows:

Wind Region A	Wind Region B	Wind Region C	Wind Region D
-	-	+ 5 %	+ 10 %

**Note 5.** If reducing screw embedment by using EZ-AD-C43 adaptor or if attaching to a smaller timber batten/purlin, fixing spacing to be reduced/increased to timber purlins as per below:

Batten type	Batten-Purlin Depth / Screw embedment	
	25 mm	30 mm
<b>Timber F7</b>	Reduction of 35%	Reduction of 25%
<b>Timber F17</b>	Spacings remain the same	Increase of 20%

**Note 6.** This engineering document was designed to cater for most common installation scenarios however, it does not cater for all of them. Contact Clenergy if you are unable to comply with any of the installation specifications listed on this document.

**Note 7.** The following components are satisfied for use according to AS/NZS 1664.1:1997-Amdt 1:1999 and AS/NZS 1170.2:2011 Amdt 4-2016

Components	Part No.	Description
ECO-Rail	ER-R-ECO/XXXX	ECO Rail
Splice	ER-SP-ECO	PV-ezRack Splice for ECO rail
Australian Made Mill Finish ECO Rail	R-ECO/XXXX/AUMF	PV-ezRack Australian Made Mill Finish ECO Rail
ST-Rail	ER-R-STXXXX	Standard Rail
Splice	ER-SP-ST	PV-ezRack Splice for Standard Rail 200mm
ECO Rail Black	ER-R-ECO/XXXX/BA	ECO Rail Black
Black Splice ECO Rail	ER-SP-ECO/BA	Splice ECO Rail Black
Inter Clamp	ER-IC-STXX	Inter Clamp = clamp + Z-Module + Bolt.
End Clamp	ER-EC-STXX	End Clamp = clamp + Z-Module + bolt
Clamp	C-U/30/46-G	Universal Clamp for Frame Height 30-46mm with Grounding Clip
Clamp	C-U/30/46	Universal Clamp for Frame Height 30-46mm
End Clamp	ER-EC-DU35/40	End Clamp dual 35 or 40mm
End Clamp	ER-EC-DU40/46	End Clamp dual 40 or 46mm
Inter Security Clamp	ER-IC-STXX/S	Inter Clamp = Clamp + Z-Module + Security Bolt
End Security Clamp	ER-EC-STXX/S	End Clamp = Clamp + Z-Module + Security Bolt

<b>Components</b>	<b>Part No.</b>	<b>Description</b>
Interface	ER-I-01, 02, 04, 23, 26 and 51	Tile Interface
Interface	ER-I-01/CS	Carbon Steel Tile Interface
Tile Interface with ezClick connection for ECO-Rail	ER-I-01/EZC/ECO	PV-ezRack SolarRoof, Tile Interface with ezClick connection for ECO-Rail
Interface	ER-I-05	Tin Interface
Black Interface	ER-I-05/BA	Black Tin Interface
Interface	ER-I-05/CM	Tin Interface with Click Module
Interface	ER-I-05A/EZC/ECO	ezClick connection for ECO-Rail
Interface	ER-I-25	Tin Interface with curved Base for corrugated Roof
Black Interface	ER-I-25/BA	Black Tin Interface with curved Base for corrugated Roof
End Clamp (*)	EC-FL/GE/XX/XX	End Clamp for Frameless Module (glued EPDM)
Inter Clamp (*)	IC-FL/GE/XX/XX	Inter Clamp for Frameless Module (glued EPDM)
End Clamp (*)	ER-EC-FL/XX/XX	End Clamp for Frameless Module
Inter Clamp (*)	ER-IC-FL/XX/XX	Inter Clamp for Frameless Module
Black End Clamp (*)	EC-FL/GE/XX/XX/B	Black End Clamp for Frameless Module (glued EPDM)
Black Inter Clamp (*)	IC-FL/GE/XX/XX/B	Black Inter Clamp for Frameless Module (glued EPDM)

Components	Part No.	Description
Adapter for Corrugated Roof	EZ-AD-C43	Adapted for Corrugated Iron Roof for Tin interface ER-I-05
Black Adapter for Corrugated Roof	EZ-AD-C43/BA	Black Adapted for Corrugated Iron Roof for Tin interface ER-I-05
Corrugated Adapter	EZ-AD-C110	PV-ezRack Adapter for Corrugated Iron Roof.
Roof Extender (Reduction Factor)	ER-RE-200	Roof Hook Extender, Suitable for ER-I-01,02,04,05,23,26, 51 and 01/CS
Connector Clamp	CRC-R/ECO-ZBW	Cross Connector Clamp for ECO-Rail
Hanger Bolt	ER-HB-10/200A	PV-ezRack, Hanger Bolt M10*200mm
Hanger Bolt	ER-HB-MP/8/150EP	PV-ezRack Hanger Bolt for metal purlin M8*150mm
Hanger Bolt	ER-HB-8/150	Hanger bolt without mounting plate M8x150. Fixed to timber purlin only
Mid Clamp XX Black	ER-IC-STXXB	Inter Clamp XX Black
End Clamp XX Black	ER-EC-STXXB	End Clamp XX Black
Black Universal Clamp	C-U/30/46-BA	Black Universal Clamp
Black Universal Clamp	C-U/30/46-G-BA	Black Universal Clamp with grounding clip

(\*) Subject to the panel manufacturer's installation guide.

**Note 8.** For Terrain Category (TC) definition, please refer to clause 4.2.1 of AS/NZS 1170.2:2011 (R2016).

**Note 9.** The installed frame must comply with the clamping zone of the PV Panel.

**Note 10.** Capacities checked and compared against testing data from Clenergy Australia and MTS (NATA certified).

**Note 11.** Maximum permitted rail overhang of 40%.

**Note 12.** For the definition of roof zones, refer to Appendix D6 of the AS/NZS 1170.2:2011 (R2016) standard.

**Note 13.** This Engineering report is based on 2 m x 1 m panels and two rails per panel. However, a percentage increase could be applied on all interface spacings as shown on the following table.

Number of rails per panel	Panel length / width (mm)	Spacing +/-
2 rails	≤ 1700/ ≤1100	+ 8 %
3 rails	≤ 1700/ ≤1100	+ 12 %
4 rails	≤ 1700 / ≤1100	+ 15 %
2 rails	≤ 2000/ ≤1100	0 %
3 rails	≤ 2000/ ≤1100	+ 10 %
4 rails	≤ 2000/ ≤1100	+ 12 %
2 rails	≤ 2100/ ≤1100	- 10 %
3 rails	≤ 2100/ ≤1100	+ 6 %
4 rails	≤ 2100/ ≤1100	+ 10 %
2 rails	≤ 2200/ ≤1100	- 13 %
2 rails	≤ 2200/ ≤1200	- 20 %

**Note 14.** From the date of publication onwards, any amendment made to any of the above-mentioned Standards will make this report outdated and a new one will have to be released, unless the amendment has no implications on this certificate.

**Note 15.** No consideration has been taken on the effect that the solar panel will have over the roof structure. It has been assumed that the roof will be able to resist the additional loadings imposed by the installation of the solar panels in conjunction with the Clenergy Mounting System.

**Note 16.** All components from Clenergy must be installed according to manufacturer's specification and the instructions shown in the relevant installation manual. Please check the Clenergy Australia website or contact them for access to the most recent installation manuals.

**Note 17.** No consideration has been taken on the effect of snow loads. In case the roof is located in a snow prone area, a special design must be made.

**Note 18.** This document does not cover the building frame capacity. It has been assumed that the building frame will be able to resist the additional loadings imposed by the installation of the solar panels in conjunction with the Clenergy mounting system.

**Note 19.** Neither Clenergy nor MW Engineering Melbourne are not to be responsible for external factors leading to compression of the tile interfaces.

**Note 20.** Topographic Multiplier (Mt) taken as 1.0. Refer to clause 4.4 of AS/NZS 1170.2:2011 (R2016) for more information.

**Note 21.** Shielding Multiplier (Ms) taken as 1.0. Refer to clause 4.3 of AS/NZS 1170.2:2011 (R2016) for more information.

**Note 22.** Wind Direction Multiplier (Md) taken as 1.0. Refer to clause 3.3 of AS/NZS 1170.2:2011 (R2016) for more information.

**Note 23.** General conditions

**Note 23.1** Minimum grade for steel purlins/battens of 450 Mpa.

**Note 23.2** Timber Grade members: F7 (Pine) and F17 (Hardwood).

**Note 23.3** If any of the screws of the interfaces go into pre-existing holes, they will have to be one size up compared to the screws that were previously installed. This is to ensure that the pullout capacity remains the same or higher.

**Note 24.** Spacings on tile interfaces will be reduced as follows:

Interface	% of Reduction
ER-I-01/CS, ER-I-51 & ER-I-01/EZC/ECO	-
ER-I-02	-50%
ER-I-04	-50%
ER-I-23	-28%
ER-I-26	-28%

**Note 25.** A minimum of two (2) screws per Tile Interface will be required for installation.

**Note 26.** For installations on the Central Zone increase ER-I-01 & ER-I-05 Interface Spacings by 10%.

**Note 27.** Use the same spacing listed on the tables of this certificate for panels installed in landscape.

**Note 28.** When using Roof Extender (ER-RE-200), reduce interface spacings by 15% on Wind Region A and B and 30% on Wind Region C and D.



**Note 29.** Conditions for flush mounted systems installed on flat and pitched roofs according to the D6 Appendix of the AS/NZS 1170.2:2011 (R2016).

- Roof pitch to be between 1° and 30°.
- $h/d \leq 0.5$  and  $h/b \leq 0.5$ . Being h= height, b= width and d= length of the building as per the below picture.
- Gap between the underside of the panel and the roof to be no less than 50mm and no more than 300mm.

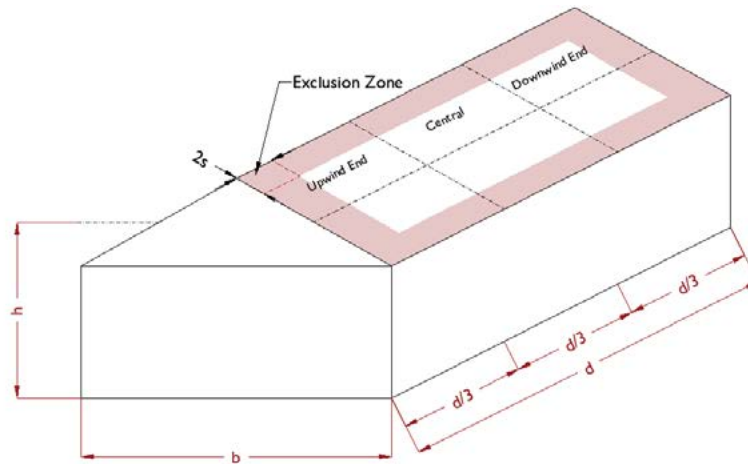

**Note 30.** Exclusion zone for flush installation to be the minimum distance from the edge of the roof "2s", where "s" is the gap between the underside of the panel and the roof.

**Note 31.** If the installation is located in ISO corrosivity category C4 reduce the interface spacing by 5%. If the installation is located in ISO corrosivity category C5 reduce the interface spacing by 25%.

**Note 32.** Roof Zone definition when the installation doesn't meet the parameter on section D6 part (d) of the AS/NZS 1170.2:2011 (R2016) standard for roof angle is between 1° to 30°.

**Step 1.** Determine building height (h), width (b) and length (d).

**Step 2.** Choose the lowest value between "h", "b x 0.2" and "d x 0.2".

**Step 3.** The lowest value on Step 2, equates to a.

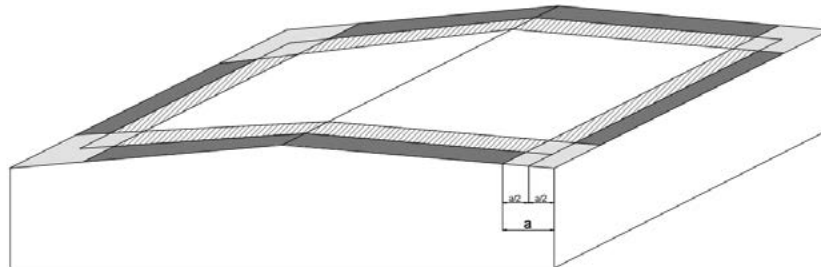

Roof Pitch <math>< 10^\circ</math>

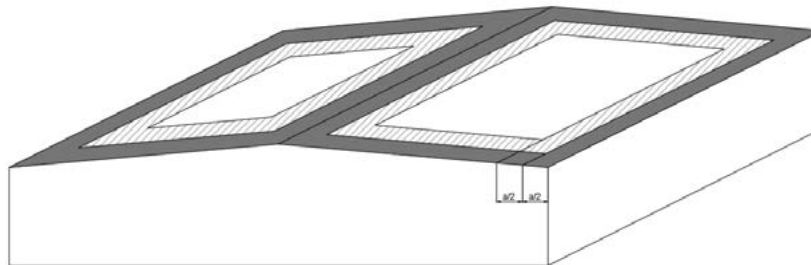

Roof Pitch  $\geq 10^\circ$

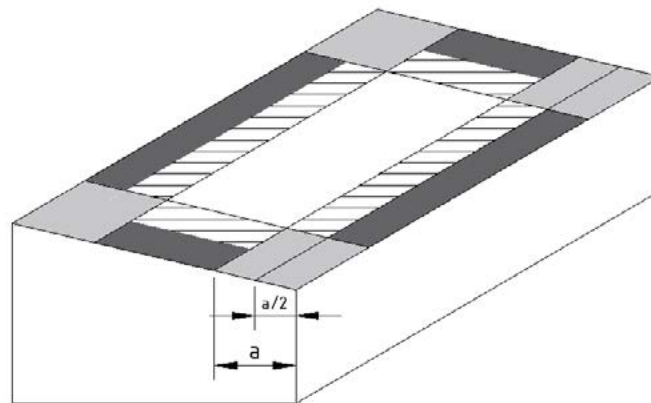

Flat/Mono – Slope Roof <math>< 10^\circ</math>

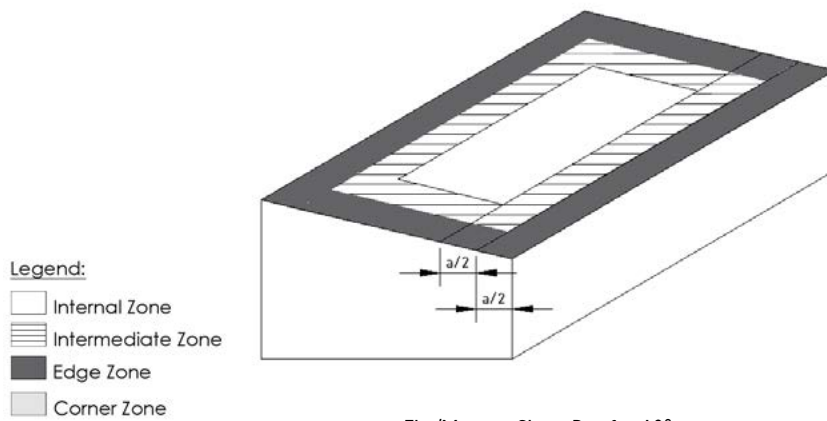

Flat/Mono – Slope Roof  $\geq 10^\circ$

**Note 33.** Zone reduction factors to be the following:

- Internal:** Use the same spacings as central zone.
- Intermediate:** Divide central zone spacings by 1.5.
- Edge:** Divide central zone spacings by 2.
- Corner:** Divide central zone spacings by 3.

**Note 34.** For Hanger Bolt installation on either tin or tile roof, the spacing to apply with a minimum embedment depth of 25mm into F7 (Pine) timber or fixing to metal purlin with 1.5 mm thickness is the same as the tin roof interface spacing (ER-I-05). The Hanger Bolts for wood purlin/rafter installation are ER-HB-8/150 and ER-HB-10/200A. The Hanger Bolt for metal purlin/rafter is ER-HB-MP/8/150EP.

**Note 35.** Neither Clenergy nor MW Engineering Melbourne will be responsible for the integrity of the roof tiles when using hanger bolts for the solar installation. It will be the clients' responsibility to check the hanger bolt installation feasibility.

Example when building parameters fall outside section D6 of the AS/NZS 1170.2:2011 (R2016) standard.

- Tin roof
- Wind Region A
- Terrain Category: 3
- Building height: 5m
- Roof pitch: less than  $10^\circ$
- Panel dimension: 2 m x 1 m
- Installation on intermediate zone to be:
  - Central spacing: 1919 mm
  - Intermediate zone: 1279 mm
- Reduction for corrosion category C4 (-5% - Note 31)
  - Central spacing: 1820 mm
  - Intermediate zone: 1215 mm



## **PV-ezRACK®**

### Clenergy

1/10 Duerdin St  
Clayton VIC 2168  
Australia

Phone: +61 3 9239 8088  
Email: [sales@clenergy.com.au](mailto:sales@clenergy.com.au)  
Web: [www.clenergy.com.au](http://www.clenergy.com.au)

 @ClenergyGlobal / @ClenergyClub / ClenergyAUS  @Clenergy  @ClenergyClub  
 @Clenergy\_global  @Clenergy

A Clenergy Technologies Company