

PostMount 3-A for XL Panels

Code-Compliant Planning and Installation Guide V 2.3

Complying with AS/NZS 1170.2: 2021

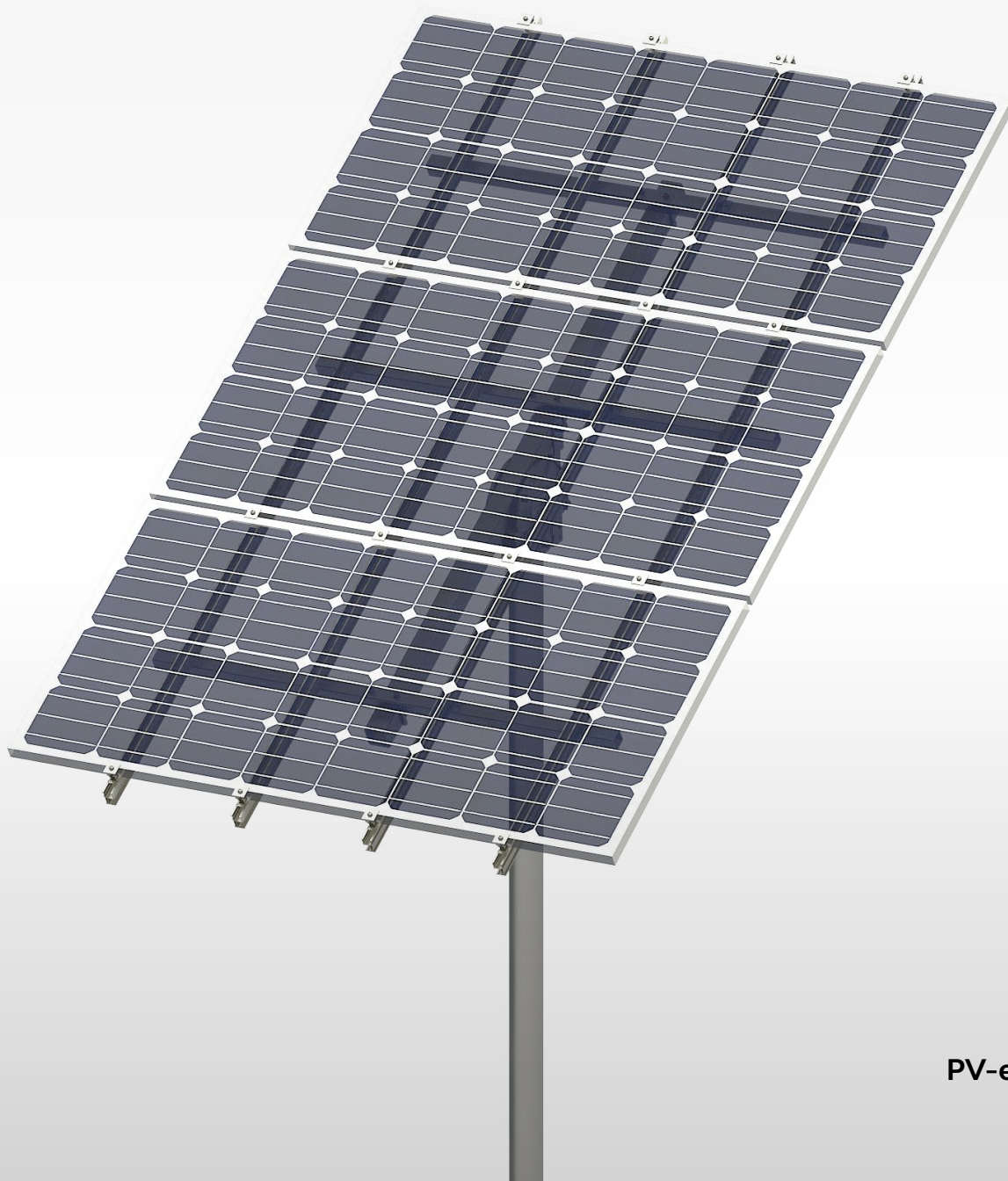

Introduction

Cleenergy PVezRack® PostMount 3-A for XL Panels (up to 2100 x 1134 mm) is a ground mounting system suitable for large scale commercial and utility scale installations. PVezRack® PostMount 3-A for XL Panels has been developed to fit any PV module in the outdoors and uneven ground areas. PVezRack® PostMount 3-A for XL Panels have good compatibility for the different region via the angle adjustment (10° ~60°). Using high quality engineered components PostMount 3-A for XL Panels saves developers and installers, time and money when delivering large scale projects.

Please review this manual thoroughly before installing PostMount 3-A for XL Panels. This manual provides the following contents:

- 1) Installation planning;
- 2) Installation instructions.

The PVezRack® PostMount 3-A for XL Panels parts, when installed in accordance with this guide, will be structurally adequate and meet the AS/NZS 1170.2: 2021 standard. During installation, and especially when working on the ground, please comply with the appropriate occupational health and safety regulations. Please also pay attention to other relevant regulations in your local region. Please check that you are using the latest version of the installation manual by contacting Cleenergy via email on www.cleenergy.com.au or contacting your local distributor.

Product Warranty:

Please refer [PVezRack® Product Warranty](#) on our website.

List of contents





Introduction	01
Tools & Components	02
System Overview	03 - 05
Installation Instruction	06 - 11
Certification	12 - 15

The installer is solely responsible for:







- Complying with all applicable local or national building codes, including any updates that may supersede this manual;
- Ensuring that PVezRack® and other products are appropriate for the particular installation and the installation environment;
- Using only PVezRack® parts and installer supplied parts as specified by PVezRack® project plan (substitution of parts may void the warranty and invalidate the letter of certification);
- Recycling: according to the local relative statute;
- Ensuring that there are no less than two professionals working on panel installation;
- Ensuring the installation of related electrical equipment is performed by licenced electricians;
- Ensuring safe installation of all electrical aspects of the PV array, including providing adequate earth bonding of the PV array and PVezRack® PostMount components as required in AS/NZS 5033: 2021.

Tools and Components

Tools

			
Allen Key 6 mm	Spanner	Torque Wrench	5m Tape

Components

				
C-U/30/46-G Akashi Clamp x 4	ER-R-ECO/XXXX ECO-Rail x 4	ER-AP-PM3/A-LP PM3-A Kit x 1	ER-P-102/2600 Pipe x 1	SC-PM2/3/4/A Steel Cap x 1
				
ER-RT-70/394 Adjustable Tube x 1	ER-RT-70/2200 Rectangular Tube-Master x 1	ER-RT-50/1400 Rectangular Tube-Landscape x 3	EZ-GL-ST/UC Grounding Lug x 2	

System Overview

Overview of PVezRack® PostMount 3-A for XL Panels

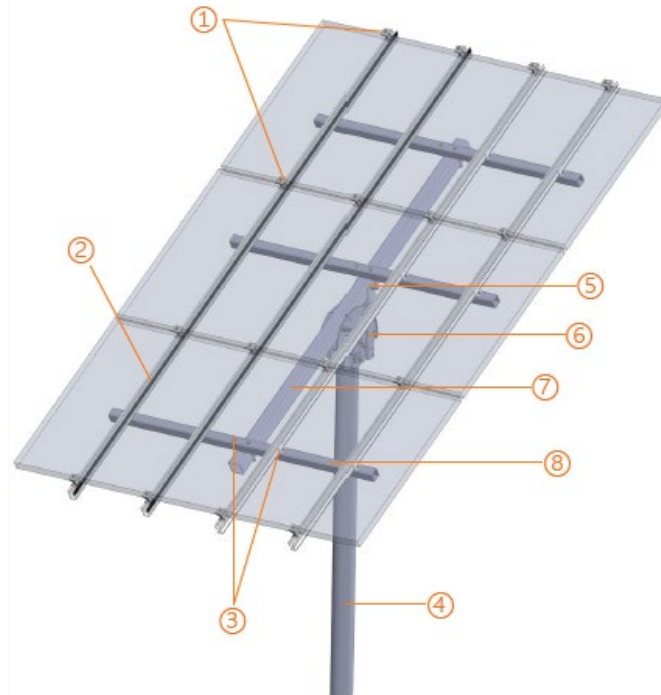

1. Akashi Clamp 2. ECO-Rail 3. PM3-A Kit 4. Pipe 5. Adjustable Tube 6. Steel Cap
7. Rectangular Tube-Master 8. Rectangular Tube- Landscape

Side view drawing of PVezRack® PostMount 3-A for XL Panels is shown below. The panels tilt angle and embedment depth below are for reference only. Please refer to Certificate Letter to obtain the certified max panels tilt angle and min embedment depth for different wind regions and different soil types.

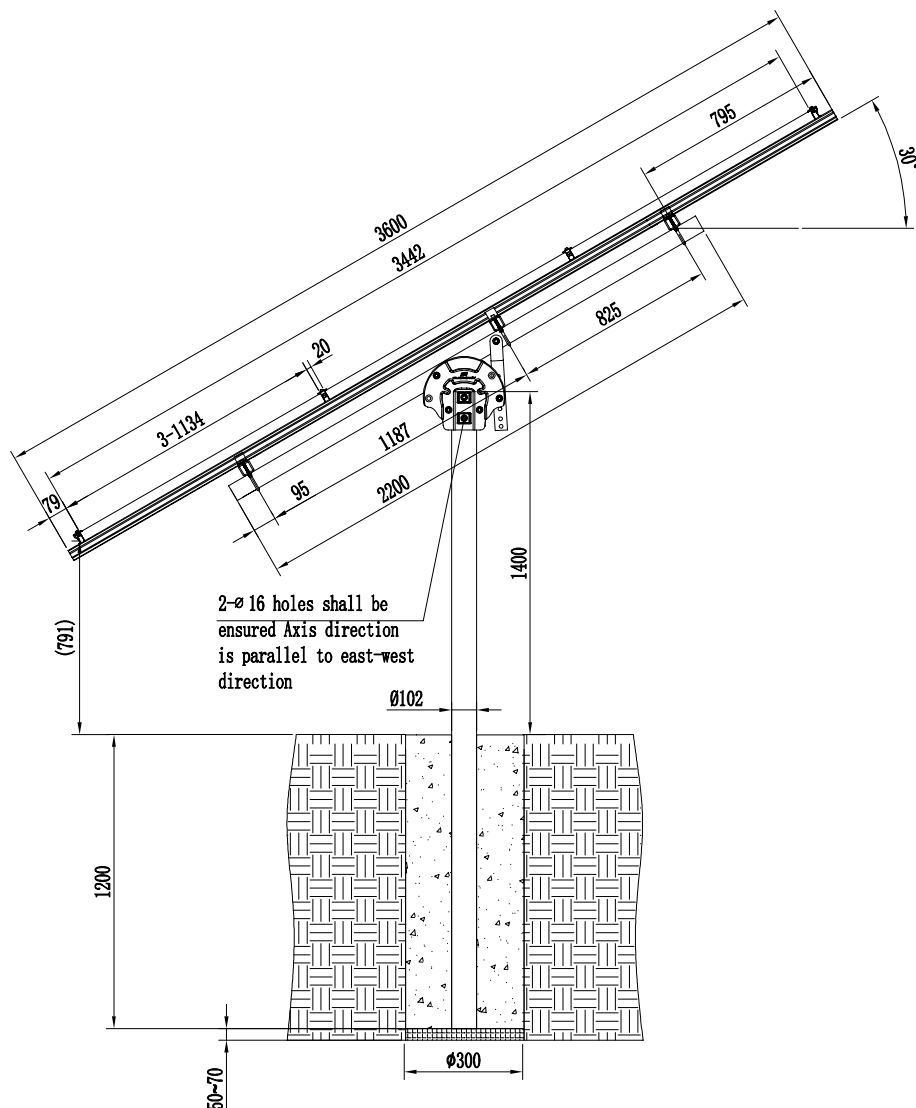

Precautionary Measures for Stainless-Steel Fastener Installation

Improper operation may lead to the deadlock of bolts and nuts. Follow the steps below to reduce this risk.

Reduce the friction coefficient

- (1) Ensure that the thread surface is clean (no dirt or contaminant).
- (2) Apply lubricant (grease or 40# engine oil) to fasteners prior to tightening to avoid galling or seizing in the threads.

General installation instructions

- (1) Apply force to fasteners in the direction of thread.
- (2) Apply force uniformly to maintain required torque.
- (3) Professional tools and tool belts are recommended.
- (4) Avoid using electric tools for final tightening.
- (5) Avoid working at high temperatures.

Safe Torques

Please refer to safe torques defined in this guide as shown in the figure below. If power tools are required, Cleenergy recommends the use of low speed only. High speed and impact drivers increase the risk of bolt galling (deadlock). If deadlock occurs and you need to cut fasteners, please make sure that there is no load on the fastener before you cut it. Avoid damaging the anodized or galvanized surfaces.

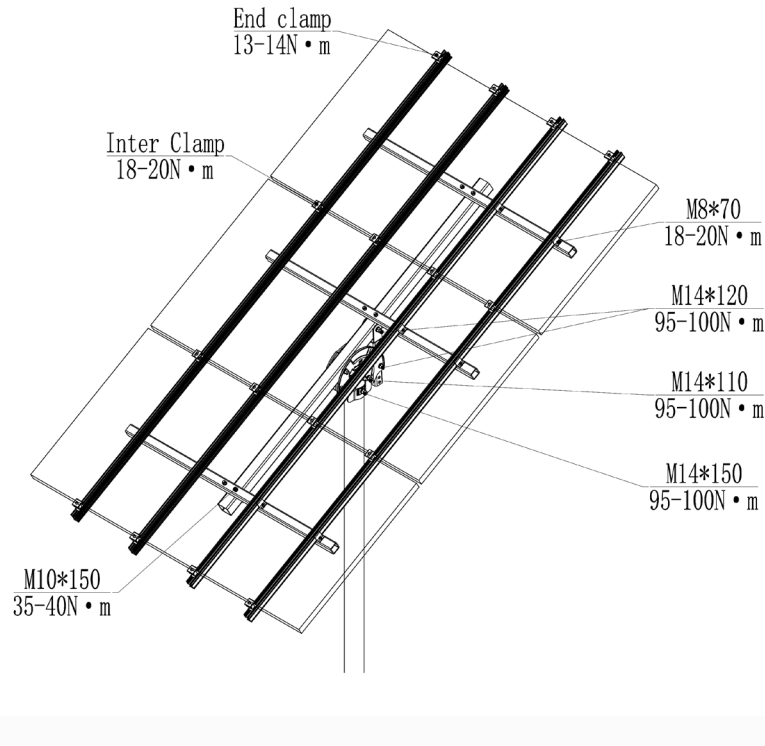

Installation Dimensions

All drawings and dimensions in this installation guide are for generic reference. The PVezRack® PostMount 3-A for XL Panels is to be optimized to suit specific conditions for each project and documented in engineering drawings. As a result, major components of the PVezRack® PostMount 3-A for XL Panels may be provided in sectional sizes and lengths that vary from those shown in this guide. The installation operations detailed in this instruction guide remain the same regardless of the component size. In case you need to do any on-site modifications or alteration of the system in a way that would be different from engineering drawings, please provide marked up drawings/sketches for Cleenergy's review prior to modification for comment and approval.

Installation Instruction

Pipe Installation

Dig a hole of diameter of 300mm in diameter.

Place the pole into the middle of the hole and fill it with concrete (min 25 MPa strength). Maintain the position of the post. The allowed vertical tolerance is $\pm 2^\circ$. Keep the axle of the 2- $\varnothing 16$ holes parallel to East-West; keep the vertical angle deviation within $\pm 5^\circ$. For more than one system on one site maintain all the axles of 2- $\varnothing 16$ holes aligned.

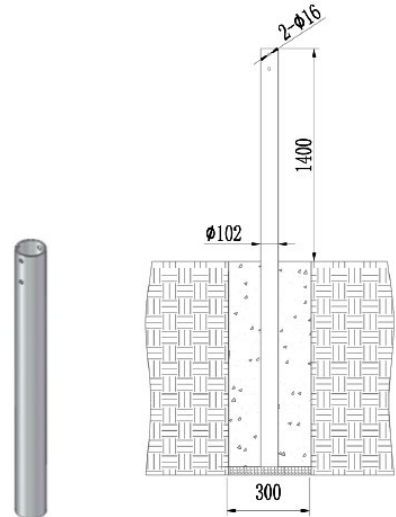

Steel Cap Installation

Connect the Pipe to the corrugated washer and Steel Cap Assembly with M14*150 hexagonal bolt, 14mm plain washer, 14mm spring washer, and M14 nut.

Combine two Steel Caps with M14*110 hexagonal bolt, 14mm plain washer, 14mm spring washer, and M14 nut.

Note:

1. Do not fasten the bolt prior to completing the assembly of PM-A Rectangular Tube-Master.
2. Keep all the bolt heads aligned.

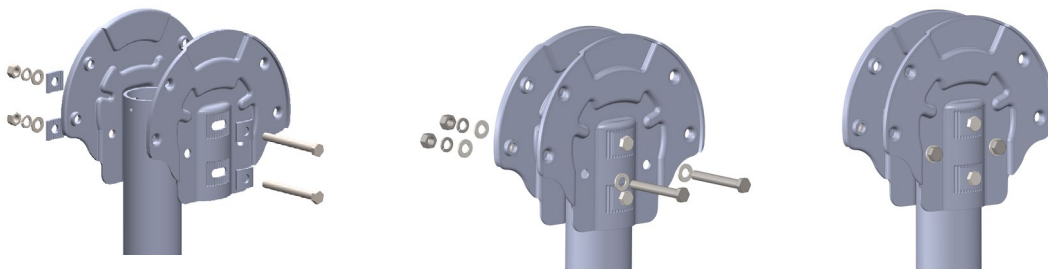

Rectangular Tube-Master and Adjustable Tube Installation

1) Fix the Rectangular Tube-Master to the Steel Cap Assembly with M14*120 hex bolt, M14 nut, plain washer 14, and spring washer 14. See the mark (1).

2) Fix the Adjustable Tube to the Rectangular Tube- Master with M14*120 hex bolt , plain washer 14, and spring washer 14, and M14 nut. See the mark (2).

3) Fix the Adjustable Tube to the Steel Cap Assembly with M14*120 hex bolt, M14 nut, plain washer 14, and spring washer 14. See the mark (3).

Adjust the tilt angle by positioning the bolt in different holes of the tube.

4) Fasten the Steel Cap Assembly to Pipe with M14*150, M14*110 Hex Bolt, keep the Rectangular Tube-Master parallel to the south-north direction by adjusting the Steel Cap Assembly.

Recommended torque for M14 bolts is 95~100 N·m.

Note:

1. Adjust the angle of elevation, before assembly, set the Rectangular Tube-Master to the 10° position (the 6 holes from top to bottom correspond to tilt angles of 10° to 60°) to allow the assembly process to proceed smoothly.
2. Using adjustable washers to fill gaps between the Rectangular Tube-Master and the Adjustable Tube and Steel Cap. Image on the right shows adjustable washers inserting between the Rectangular Tube-Master and Steel Cap.

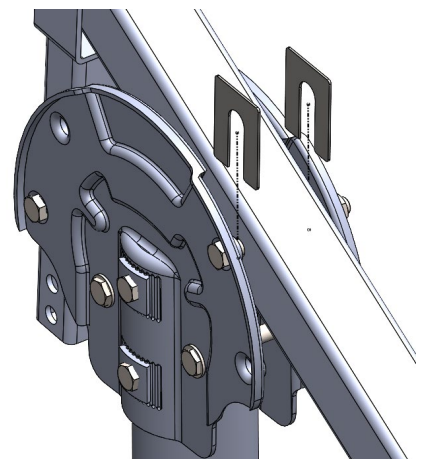
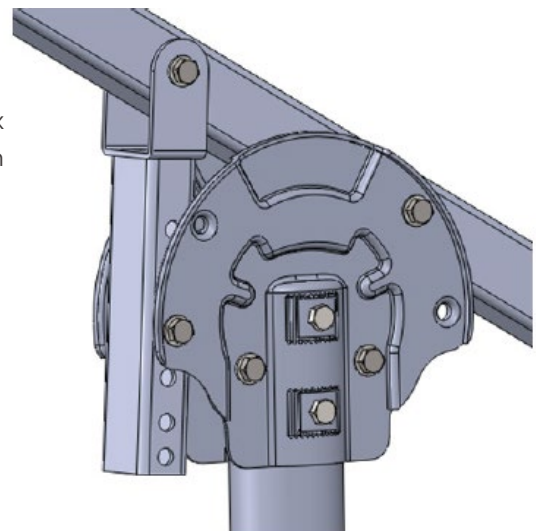
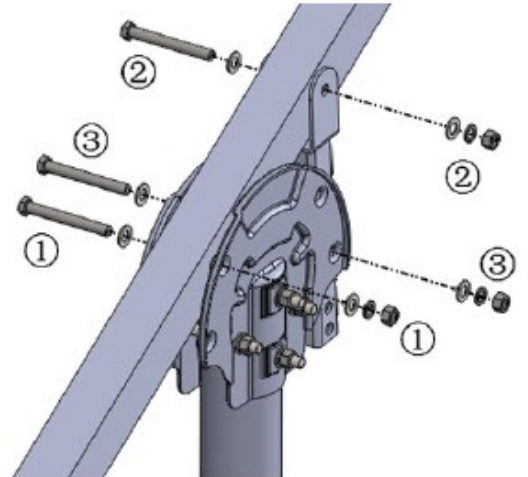

Rectangular Tube-Landscape Installation

1) Fix the 3 pcs of PM Rectangular Tube-Landscapes to the Rectangular Tube-Master with 3 pcs U-bolts, 6 pcs M10 nuts, 6 pcs spring washers 10, and 6 pcs plain washers 10. Do not fasten the Nut until the 3 Rectangular Tube-Landscapes are aligned.

Note:

Adjust the Rectangular Tube-Landscapes until the dimension $D1=D2$, $D3=D4$.

Recommended torque for M10 bolts is 35~40 N-m.

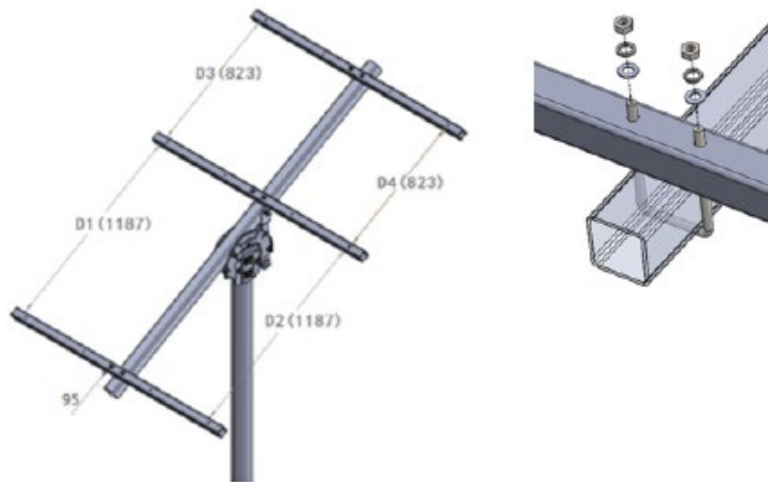

2) Preassemble the Cross Connection Clamp at the Rectangular Tube-Master with M8*70 hex bolts, plain washer 8, spring washer 8, and M8 nut as shown in the figure below.

Note:

Do not fasten the M8*70 hex bolt in order to make other clamp fit well.

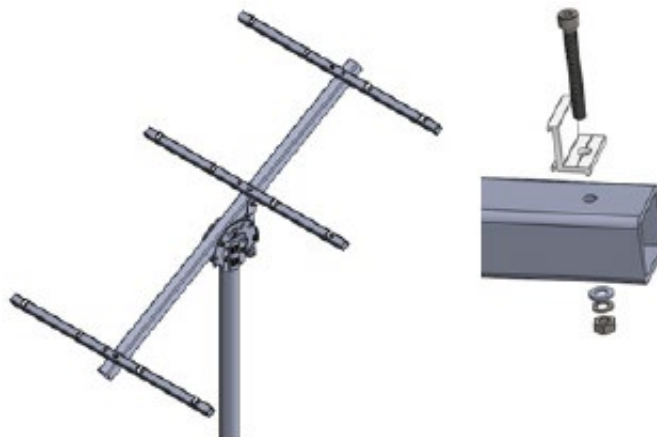

ECO-Rail Installation

Lift the Cross Connection Clamp at the required angle. Click the Clamp into the ECO-Rail. Position the Rail in the middle of the Rectangular Tube-Master, and then fasten the M8*70 bolt.

Recommended torque for M8 bolts is 18~20 N·m.



6. PV Module Installation

Fix the PV panel to the rail, via Universal Inter Clamps and End Clamps step by step until all the panels secured.

Recommended torque for M8 bolts is 18~20 N·m.

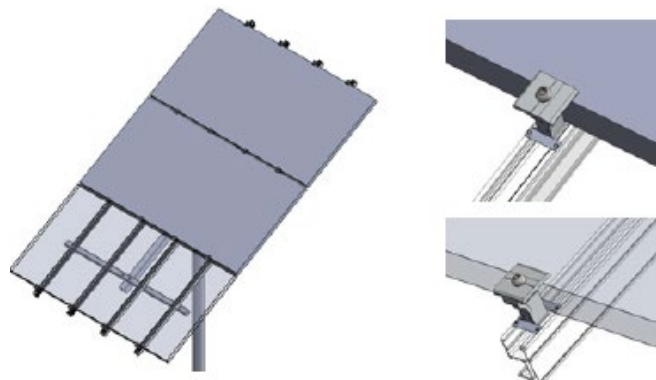

Note:

The Akashi Clamp can be used both as a End Clamp and a Inter Clamp, and the height can be adjusted from 30 to 46 mm.

When the side of the Akashi Clamp close the narrow side of the Akashi Clamp Buckle, it can be used as End Clamp, and when the side of the Akashi Clamp close the wide side of the Akashi Clamp Buckle, it can be used as Inter Clamp, as shown in the figure below. The Akashi Clamp can be directly rotated to the position of required End or Inter Clamp.

Recommended torque for M8 bolts when it is Inter Clamp is 18~20 N·m.

Recommended torque for M8 bolts when it is End Clamp is 13~14 N·m.

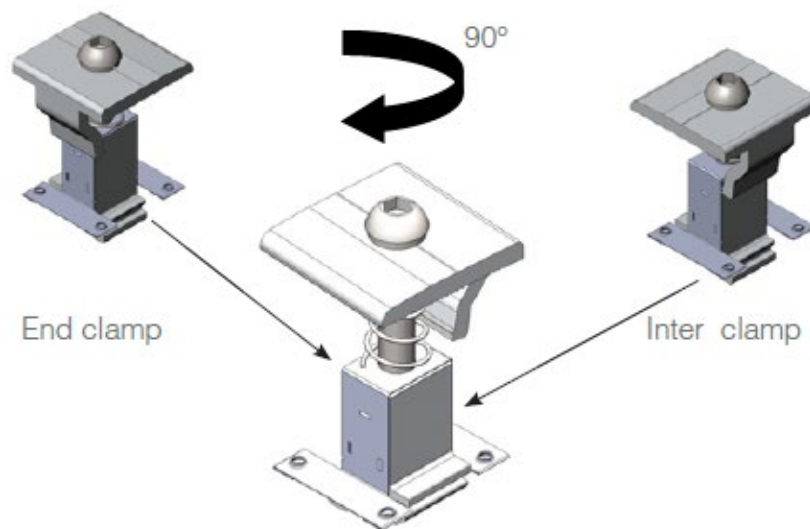

Apply one pre-assembled Grounding Lug per Rail. Click the Grounding Lug into to the rail channel and insert the Copper Wire (the maximum size is 10 mm²). Fasten the bolt M6*14 with 5~6 N·m and the bolt M8*25 with 16~20 N·m.

There are three solutions for Grounding Lug installation.

Solution 1:

Fix the Grounding Lug at the end of the rail as shown in the figure on the right.



Solution 2:

Fix the Grounding Lug on the rail directly beneath the PV Module as shown in the figure on the right.

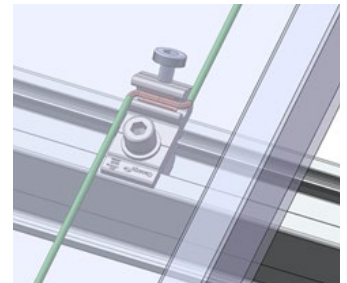

Solution 3:

Fix the Grounding Lug in the side channel of the rail as shown in the figure on the right.

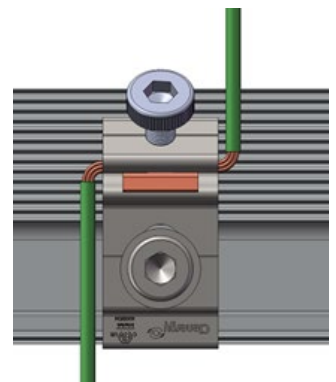

Certification



CLENERGY POST MOUNTING SYSTEM PM3-A/XL GENERAL ENGINEERING CERTIFICATE

Prepared for:

Clenergy

3/10 Duerdin Street,

Clayton VIC 3168

April 14, 2026

Ref: E25082887

OVERVIEW

This structural assessment report is issued for the Clenergy Post Mount PM3-A/XL system based on information provided by Clenergy. The assessment is carried out using sound engineering methodologies. The assessment conditions and findings are given in the following sections.

AUSTRALIAN STANDARDS

- AS/NZS 1170.0:2002 – Structural design actions, Part 0: General principles
- AS/NZS 1170.1:2002 (R2016) – Structural design actions, Part 1: Permanent, imposed and other actions
- AS/NZS 1170.2:2021 – Structural design actions, Part 2: Wind actions
- AS/NZS 1664.1:1997 – Aluminium Structures
- AS 4100:2020 – Steel structures
- AS 2159:2009 – Piling – Design and Installation

ASSESSMENT CONDITIONS

The design checks have been based on the information and parameters provided by Clenergy, as listed below.

- Clenergy Post Mount PM3-A/XL system members:

Component Description	Part No.	Material
Racking Frame Bottom Beam	ER-RT-70/2200	Q235B
Racking Frame Top Beam	ER-RT-50/1400	Q235B
Racking Frame Bracing	ER-RT-70/394	Q235B
Rail	ER-R-ECO/XXXX	AL6005-T5
Racking Frame Post	ER-P-102/2600	Q235B
Connection for Post & Top Beam	SC-PM2/3/4/A	Q235B
Angle Bracket	ER-AP-PM3/A-LP	Q235B
PV-ezRackd End Clamp for Panel – Standard XX	ER-EC-STXX	AL6005-T5
PV-ezRack Inter Clamp for Panel – Standard XX	ER-IC-STXX	AL6005-T5
Universal Clamp for Panel	C-U/30/46-G	AL6005-T5

- Design Parameters:

- o Frame pitches = 10°, 20°, 30°, 40°.
- o Design Life = 25 years
- o Annual Probability of Exceedance = 1:100
- o Wind regions A, B1
- o Maximum ground clearance allowed by this certificate is 550mm.
- o Terrain Category = 2.0, 3.0
- o $M_s = 1.0$
- o $M_t = 1.0$
- o Self-weight of Solar Panels = 15kg/m²



ABN: 20 646 315 013
 INFO@EBULENCONSULT.COM.AU
 SUITE 2, WATERMAN WORKSPACES,
 3-7 HAMILTON ROAD, MONT ALBERT, VIC 3127
 +61 3 9259 3400

- Maximum Solar Panel Length = 2.1m
- Maximum Solar Panel Width = 1.134m
- Pile Foundation Types:
 - Pre-drilling concrete piles (300mm diameter, minimum compressive strength $f_c=25\text{MPa}$)
 - Maximum 400mm plain concrete is allowed at the bottom of pre-drilling concrete piles
- Soil Types:
 - Maximum of 200mm topsoil/organic top layer
 - Cohesive Soil: Firm to Stiff Clays, Very Stiff to Hard Clays
 - Non-cohesive Soil: Medium to Dense Sands, Compact Sands
 - Refer Table.1 for detailed soil design parameters adopted in this certificate.
- Services Near Proposed Clenergy Post Mount PM3-A/XL System Location:
 - Presence of any services (electrical, water, etc.) within the plan area of future proposed ground mounting system has not been considered in this certificate.
 - The installer/contractor is responsible for verifying services, conducting appropriate clash detection and liaising with service providers if applicable.
 - Construction of services trenches in proximity (within 1500mm from piles of ground mounting system) will require a project specific design.
- Corrosivity Conditions:
 - The installer/contractor is responsible for verifying if project site conditions are suitable for the proposed post mounting system installation in terms of corrosivity and durability.

Table 1 – Soil Design Parameters

Parameter	Values Adopted
Geotechnical Strength Reduction Factor	0.7
Cohesion of Firm to Stiff Clays	75kPa
Cohesion of Very Stiff to Hard Clays	100kPa
Depth of Soil Ignored	200mm
Diameter of Predrilled Piles	300mm
Angle of Internal Friction of Clays	10°
Angle of Internal Friction of Medium to Dense Sands	35°
Angle of Internal Friction of Compact Sands	40°
Ultimate Soil End Bearing Pressure of Medium to Dense Sands	600kPa
Ultimate Soil End Bearing Pressure of Compact Sands	900kPa

INSTALLATION RECOMMENDATIONS

Our recommendations for installation are listed based on the above-mentioned specifications.

Table 2a – Installation Guides

Region A – TC3 – Footing Options				
Tilt Angle (°)	10	20	30	40
Max Vertical Upwards Reaction (kN)	1.7	3.6	5.6	6.1
Max Vertical Downwards Reaction (kN)	4.3	5.8	7.2	9.7
Max Horizontal Reaction (kN)	0.6	1.9	4.1	6.4
Max Moment at GL (kNm)	1.5	4.2	8.5	10.8
	300mm Diameter Concrete Piers Minimum Embedment Depth (m)			
Firm to Stiff Clays	1.2	1.2	1.4	1.6
Stiff to Hard Clays	1.2	1.2	1.3	1.4
Medium Dense Sand	1.2	1.2	1.6	1.7
Compact Sand	1.2	1.2	1.4	1.6

Table 2b – Installation Guides

Region A – TC2 – Footing Options			
Tilt Angle (°)	10	20	30
Max Vertical Upwards Reaction (kN)	2.3	4.6	7.0
Max Vertical Downwards Reaction (kN)	4.7	6.5	8.3
Max Horizontal Reaction (kN)	0.7	2.2	4.9
Max Moment at GL (kNm)	1.8	5.1	10.2
	300mm Diameter Concrete Piers Minimum Embedment Depth (m)		
Firm to Stiff Clays	1.2	1.2	1.5
Stiff to Hard Clays	1.2	1.2	1.4
Medium Dense Sand	1.2	1.3	1.7
Compact Sand	1.2	1.2	1.5



ABN: 20 646 315 013
 INFO@EBULENCONSULT.COM.AU
 SUITE 2, WATERMAN WORKSPACES,
 3-7 HAMILTON ROAD, MONT ALBERT, VIC 3127
 +61 3 9259 3400

Table 2c – Installation Guides

Region B1 – TC3 – Footing Options			
Tilt Angle (°)	10	20	30
Max Vertical Upwards Reaction (kN)	2.8	5.4	8.2
Max Vertical Downwards Reaction (kN)	5.1	7.1	9.1
Max Horizontal Reaction (kN)	0.8	2.5	5.6
Max Moment at GL (kNm)	2.1	5.8	11.7
	300mm Diameter Concrete Piers Minimum Embedment Depth (m)		
Firm to Stiff Clays	1.2	1.2	1.7
Stiff to Hard Clays	1.2	1.2	1.4
Medium Dense Sand	1.2	1.4	1.8
Compact Sand	1.2	1.3	1.6

Table 2d – Installation Guides

Region B1 – TC2 – Footing Options			
Tilt Angle (°)	10	20	30
Max Vertical Upwards Reaction (kN)	3.7	6.8	11.9
Max Vertical Downwards Reaction (kN)	5.8	8.2	10.5
Max Horizontal Reaction (kN)	0.9	3.0	6.8
Max Moment at GL (kNm)	2.5	7.0	11.9
	300mm Diameter Concrete Piers Minimum Embedment Depth (m)		
Firm to Stiff Clays	1.2	1.3	1.8
Stiff to Hard Clays	1.2	1.2	1.5
Medium Dense Sand	1.2	1.6	2.1
Compact Sand	1.2	1.5	1.9



ABN: 20 646 315 013
INFO@EBULENCONSULT.COM.AU
SUITE 2, WATERMAN WORKSPACES,
3-7 HAMILTON ROAD, MONT ALBERT, VIC 3127
+61 3 9259 3400

IMPORTANT NOTES

- This assessment only covers the Cleenergy Post Mount PM3-A/XL system and its concrete pile footing based on the conditions listed above and assumed geotechnical parameters. This assessment does not include the solar PV panel or specific site geotechnical conditions.*
- Construction is to be carried out strictly in accordance with the manufacturer's instruction manual.*
- The contractor is responsible for properly setting out the pile locations. Maximum tolerances of 50mm shall be allowed during construction phase.*
- Temporary lining of shafts as necessary shall be provided by the contractor to prevent collapse due to the presence of unstable material, groundwater or other unforeseen circumstances. The contractor shall provide all equipment necessary for placement and removal of temporary liners. Where the final cut-off level is above natural ground level, the piles must be formed to the correct level by using temporary liners.*
- The above installation recommendations shall not be adopted if groundwater is encountered on site.*

Certified by:



Tianhong Zheng
B.Eng (Civil), M.Eng (Structural)
MIEAust, NER

APPENDIX A – CLENERGY POST MOUNT PM3-A/XLS SYSTEM

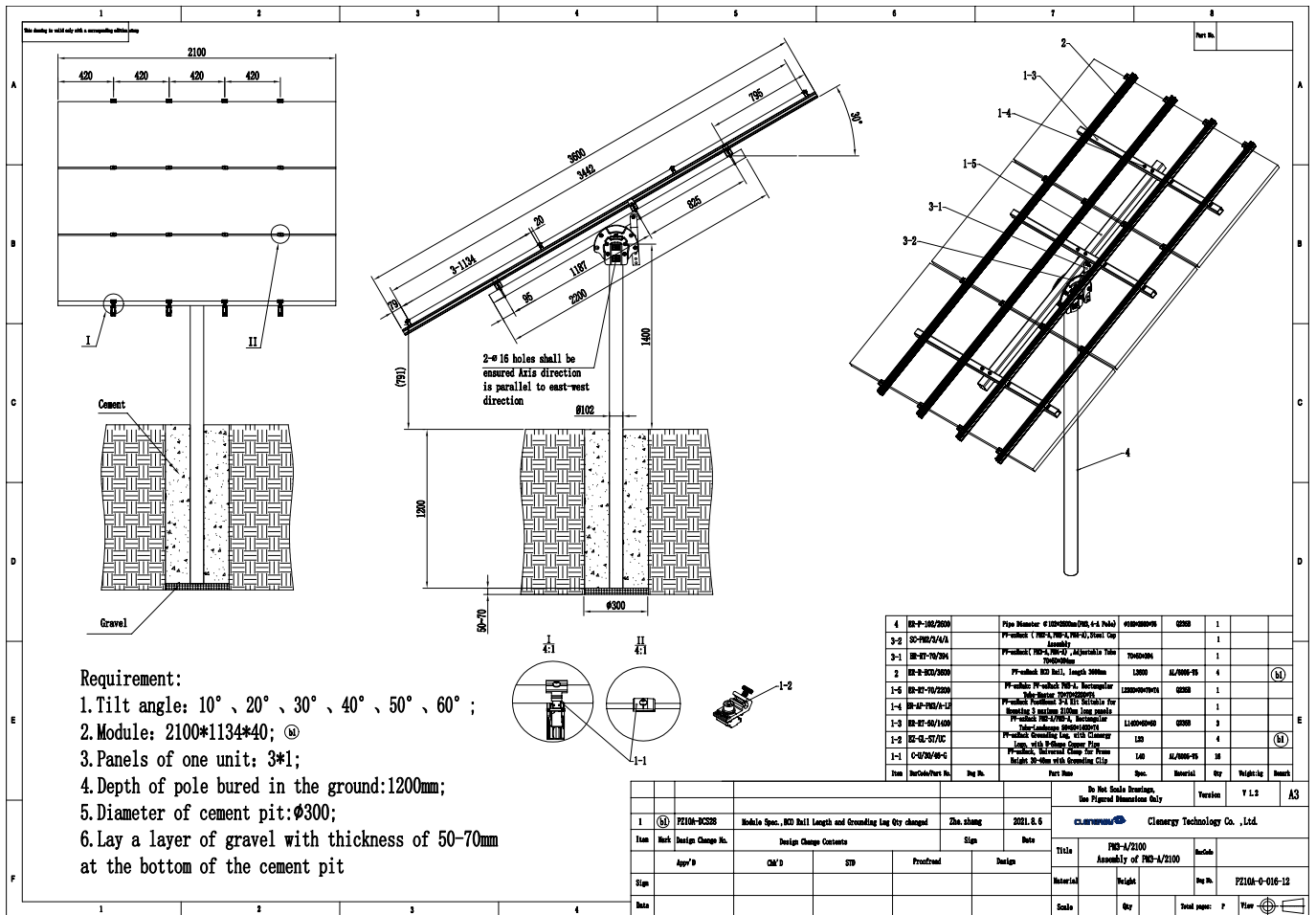

Figure A1 – Clenergy Post Mount PM3-A/XL System Design Drawing (30 Degree Tilt Case)

Change History

No.	Version No.	Amendment Details	Author	Review	Date
1	V2.2	Template and Certificate Drawing Update for 2100x1134mm Panels	Angelia.lin	Shams	02/06/2026
2	V2.3	Update Description	Angelia.lin	Shams	22/06/2026



Clenergy Technology

Unit 3, 10 Duerdin Street,
Clayton, VIC 3168,
Australia

- +61 3 9239 8088
- sales@clenergy.com.au
- www.clenergy.com.au

Last Updated - Jun. 2026