

ComT

Code-Compliant Planning and Installation V2.0
Complying with AS/NZS1170.2:2011 AMDT 2-2012



Introduction

The PV-ezRack® ComT is developed for PV installation on flat or pitched roofs. The unique fixing parts can be quickly and easily installed with simple tools.

Please review this manual thoroughly before installing PV-ezRack® ComT. This manual provides:

- 1) Supporting documentation for building permit applications relating to PV-ezRack® ComT.
- 2) Planning and installation instructions.

List of contents

Introduction	01
Planning	02
Tools and Components	05
System Overview	07
Installation Instruction	09
Certification	17

The PV-ezRack® ComT parts, when installed in accordance with this guide, will be structurally sound and will meet the AS/NZS1170.2:2011 Amdt 2-2016 standard. During installation, and especially when working on the roof, please comply with the appropriate Occupational Health and Safety regulations.

Please also pay attention to any other relevant State or Federal regulations. Please check that you are using the latest version of the Installation Manual, which you can do by contacting Clenergy Australia via email on tech@clenergy.com.au, or contacting your local distributor in Australia.

Product Warranty:

Please refer [PV-ezRack® Product Warranty](#) on our website.

The installer is solely responsible for:

- Complying with all applicable local or national building codes, including any updates that may supersede this manual;
- Ensuring that PV-ezRack and other products are appropriate for the particular installation and the installation environment;
- Using only PV-ezRack parts and installer-supplied parts as specified by PV-ezRack project plan (substitution of parts may void the warranty and invalidate the letter of certification);
- Recycling: Recycle according to the local relative statute;
- Removal: Reverse installation process;
- Ensuring that there are no less than two professionals working on panel installation;
- Ensuring the installation of related electrical equipment is performed by licenced electricians;
- Ensuring safe installation of all electrical aspects of the PV array, This includes adequate earth bonding of the PV array and PV-ezRack® SolarRoof components as required in AS/NZS 5033: 2021;
- Ensuring that the roof, its rafters/purlins, connections, and other structural support members can support the array under building live load conditions;
- Ensuring that screws to fix interfaces have adequate pullout strength and shear capacities as installed;
- Maintaining the waterproof integrity of the roof, including selection of appropriate flashing;
- Verifying the compatibility of the installation considering preventing electrochemical corrosion between dissimilar metals. This may occur between structures and the building and also between structures, fasteners and PV modules, as detailed in AS/NZS 5033: 2021.
- Verifying atmospheric corrosivity zone of installation site by referring to AS 4312-2008 or consulting local construction business to determine appropriate products and installations.

Planning

Determine the wind region of your installation site

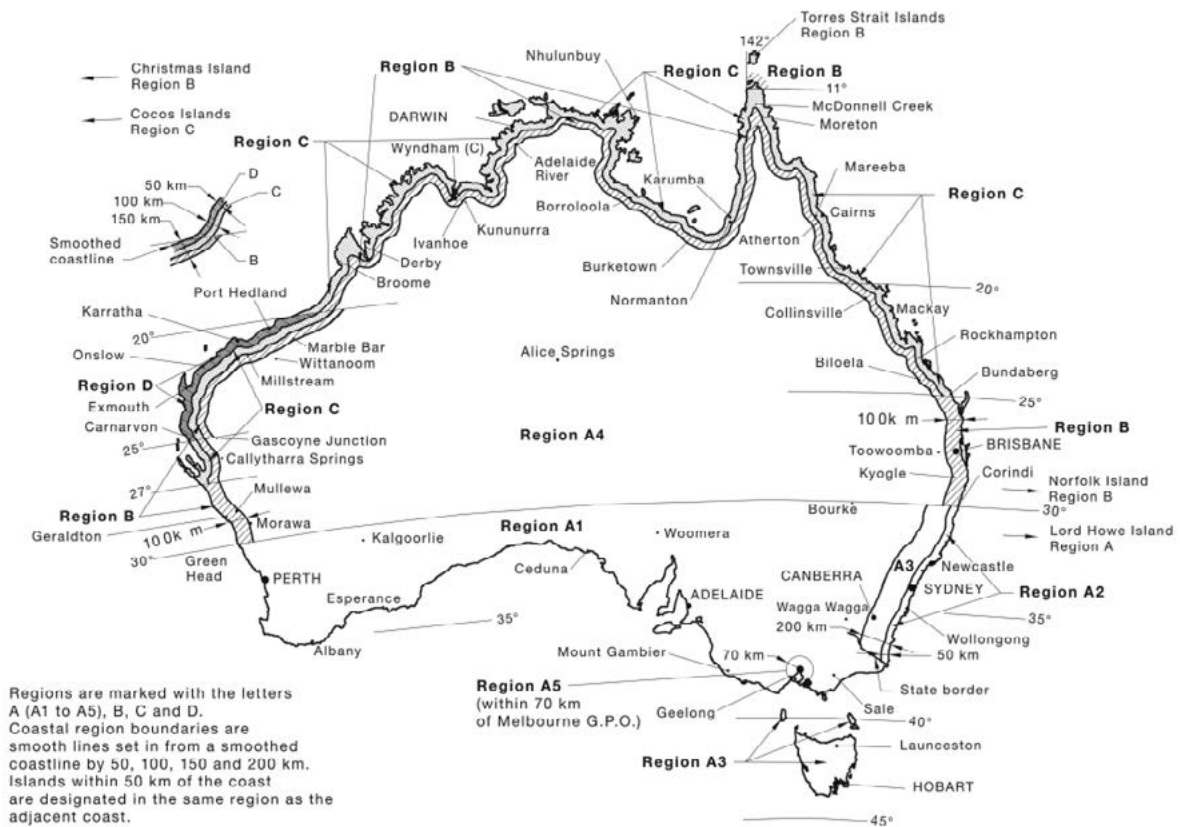

Region Definition

Wind regions are pre-defined for the whole of Australia by the Australian Standard 1170.2. The Wind Region is an independent factor of surrounding topography or buildings.

- Most of Australia is designated Region A which indicates a Regional Wind Velocity of 45 m/s with wind average recurrence of 500 years.
- Some areas are designated Region B (57 m/s). Local authorities will advise if this applies in your area.
- Region C areas (69 m/s) are generally referred to as Cyclonic and are generally limited to northern coastal areas. Most Region C zones end 100km inland.
- Region D (88 m/s) is Australia's most extreme Cyclonic Region, located between the town of Carnarvon and Pardoo Station in Western Australia.

Determine the Terrain Category

You will need to determine the terrain category to ensure the installation meets the required standard.

Terrain Category 1 (TC1) – Very exposed open terrain with few or no obstructions and enclosed, limited-sized water surfaces at serviceability and ultimate wind speeds in all wind regions, e.g. flat, treeless, poorly grassed plains; rivers, canals and lakes; and enclosed bays extending less than 10km in the wind direction.

Terrain Category 1.5 (TC1.5) – Open water surfaces subjected to shoaling waves at serviceability and ultimate wind speeds in all win regions, e.g. near-shore ocean water; larger unenclosed bays on seas and oceans; lakes; and enclosed bays extending greater than 10km in the wind direction. The terrain height multipliers for this terrain category shall be obtained by the linear interpolation between the values for the TC1 and TC2.

Terrain Category 2 (TC2) – Open terrain, including grassland, with well-scattered obstructions having heights generally from 1.5m to 5m, with no more than two obstructions per hectare, e.g. farmland and cleared subdivisions with isolated trees and uncut grass.

Terrain Category 2.5 (TC2.5) – Terrain with a few trees or isolated obstructions. This category is intermediate between TC2 and TC3 and represents the terrain in developing outer urban areas with scattered houses, or larger acreage developments with fewer than ten buildings per hectare. The terrain-height multipliers for this terrain category shall be obtained by linear interpolation between the values for the TC2 and TC3.

Terrain Category 3 (TC3) – Terrain with numerous closely spaced obstructions having heights generally from 3m to 10m. The minimum density of obstructions shall be at least the equivalent of 10 house sized obstructions per hectare, e.g. suburban housing or light industrial estates.

Terrain Category 4 (TC4) – Terrain with numerous larger, high (10m to 30m tall) and closely-spaced constructions buildings, such as large city centers and well-developed industrial complexes.

If your installation site is not at TC 2, 2.5 or 3, please contact Clenergy to obtain a project specific engineering certificate to support your installation.

Verify Atmospheric Corrosivity Zone of Installation Site

Please refer to “AS 4312-2008 Atmospheric Corrosivity Zones in Australia” or consult local construction business to verify corrosivity category of installation site to determine appropriate products and interface spacing. When standard products are installed in high corrosivity zones, like C4/C5, interface spacing reduction factor need to be applied. Please refer to the generic notes of Certification Letter for the details.

Determine the Height of the Installation Site

This document provides sufficient information for the PV-ezRack® ComT system installation up to heights of 30 meters. If your installation site is more than 30 meters high please contact Clenergy to obtain project specific engineering certificate to support your installation.

Determine System Tilt Angle

The PV-ezRack® ComT system is fixed 10° tilt system.

Determine System Tilt Angle

The PV-ezRack® ComT system is fixed 10° tilt system.

Determine Roof slope

The PV-ezRack® ComT system can be used for roof slopes up to 30°. Please verify that the Installation site roof slope is between 0° and 30°.

Determine the Installation Area of Roof

Please refer to PV-ezRack® ComT Interface Spacing Table in Certification Letter.

Verify Rafter/Purlin Properties of Building

Please verify rafter/purlin properties of building, which could affect the interface spacing. For example, tin interface spacing on the metal purlin in the certification letter is based on steel purlin G450 1.5 mm thick. If the steel purlin is less than 1.5 mm thick, the corresponding reduction factor of interface spacing will be applied. Please refer generic notes for details.

Determine the Maximum Rail Support Spacing

Please refer to the Certification Letter and Interface Spacing Table. If a project specific Certification Letter has been provided, please refer to the support spacing in this letter.

Verify Maximum Rail End Overhang









Rail end overhang should be not over 40% of the interface spacing. For example, if the interface spacing is 1500mm, the Rail end overhang can be up to 600mm only.

Acquire PV Modules Clamping Zone Information











It is recommended to acquire PV modules clamping zone info. from PV modules manufacturer, which can help to plan interfaces positions on the roof and rails orientation and positions.

Tools and Components





Tools

				
Impact Driver (Max. torque≥20N.m, for M8 bolt)	String	Torque Spanner	5m Tape	Marker Pen
				
6mm Ball Head Driving Socket – 55 mm long (provided by the Clenergy)	Open Spanner, 14mm	12" long Driving Socket Extension (optional)		

Components

				
FL-COMT/Z/G/10 Front Leg Assembly, 10°, with Z-Module and Grounding Pins	RL-COMT/Z/G/10 Rear Leg Assembly, 10°, with Z-Module and Grounding Pins	ER-RC-T/DM Rail Clamp for T-Rail, with Diamond Module	S-MT/240 MT-Rail Support	ER-R-ECO ECO Rail
				
ER-R-T50 T50 Rail	ER-R-T110 T110 Rail	ER-I-05 Tin Interface	ER-I-05/CM Tin Interface with Click Module	ER-I-05A/EZC/ECO Tin Interface A with ezClick connection

Components

				
<p>ER-I-25 Tin Interface with Curved Base for Corrugated Roof</p>	<p>EZ-CT-40/40/2560 MT-rail Cable Tray</p>	<p>CO-MT/855 Cover for MT-rail Cable Tray</p>	<p>EZ-Z-STBW Z module with Bolt and Washer</p>	<p>EZ-GC-ST Grounding Clip</p>
 <p>EZ-GL-ST Grounding Lug</p>				

System Overview

Tin Interface with Eco Rail

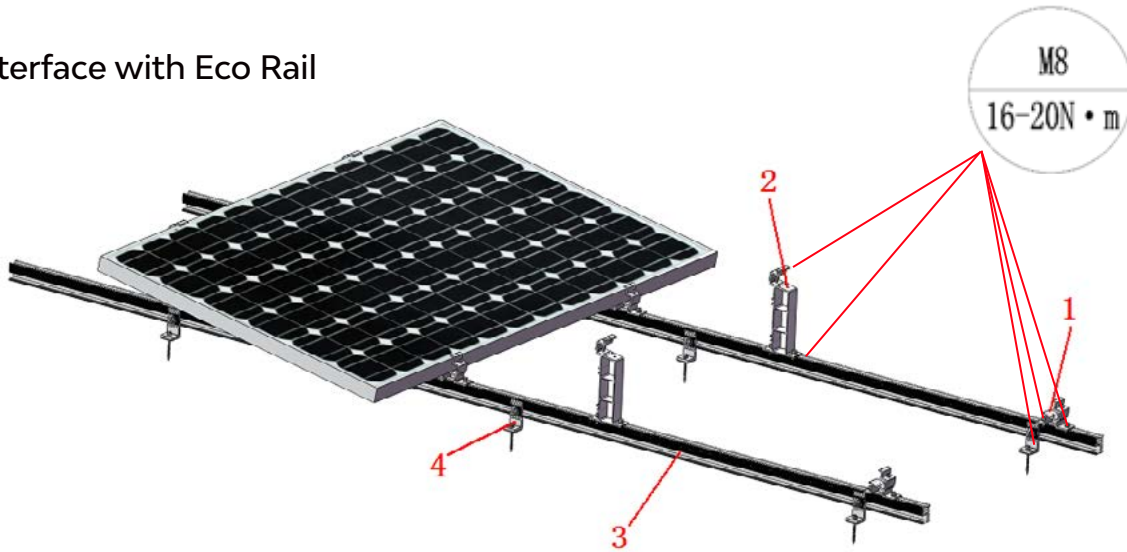

Item	Material	Spec.(mm)
1	PV-ezRack ComT, Front Leg Assembly, 10°, with Z-Module and Grounding Pins	L40
2	PV-ezRack ComT, Rear Leg Assembly, 10°, with Z-Module and Grounding Pins	L40
3	PV-ezRack ECO Rail, length 4200mm	L4200
4	PV-ezRack SolarRoof ,Tin Interface	L40

MT-Rail Support with T50/T110 Rail

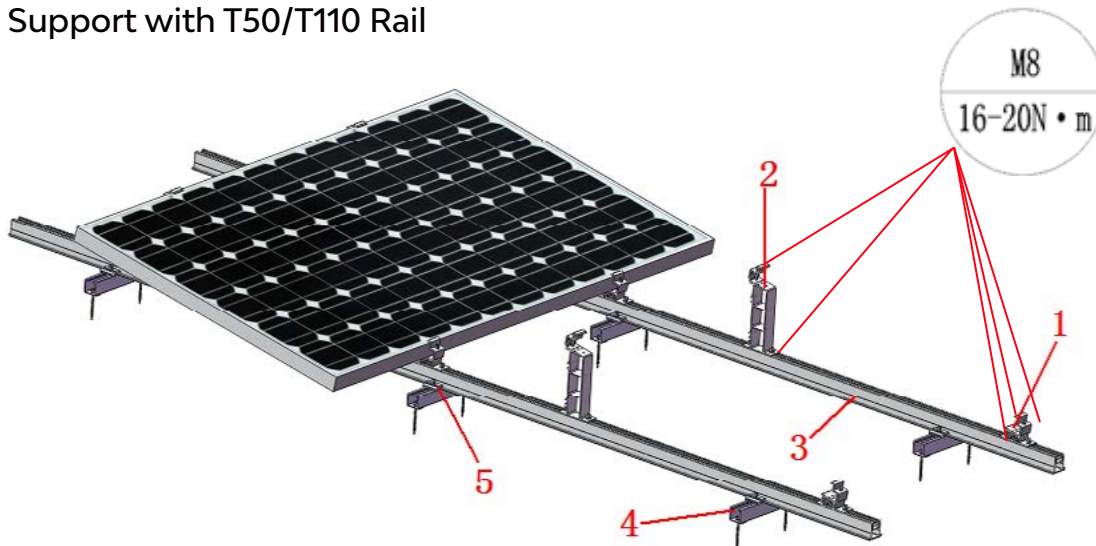

Item	Material	Spec.(mm)
1	PV-ezRack ComT, Front Leg Assembly, 10°, with Z-Module and Grounding Pins	L40
2	PV-ezRack ComT, Rear Leg Assembly, 10°, with Z-Module and Grounding Pins	L40
3	PV-ezRack T-Rail, 50*4200 mm / T-Rail 110*4200	L4200
4	PV-ezRack Rail Clamp for T-Rail, with Diamond Module	L40

Side View Drawing (992 mm wide panel as an example)

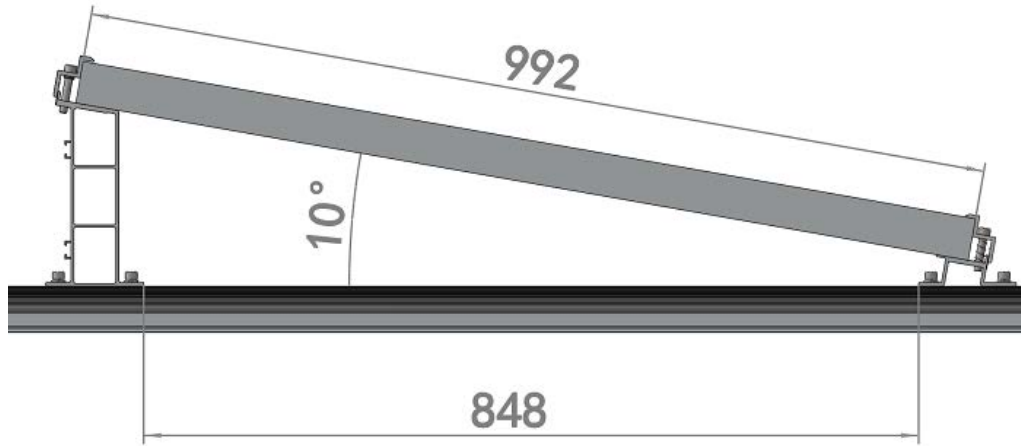

Note: For safety reason, please wear working gloves to protect hands from cut of some sharp edges of components

Precautions during Stainless Steel Fastener Installation

Improper operation may lead to deadlock of Nuts and Bolts. The steps below should be applied to stainless steel nut and bolt assembly to reduce this risk.

General installation instructions:

- (1) Apply force to fasteners in the direction of thread
- (2) Apply force uniformly, to maintain the required torque
- (3) Professional tools and tool belts are recommended
- (4) In some cases, fasteners could be seized over time. As an option, if want to avoid galling or seizing of thread, apply lubricant (grease or 40# engine oil) to fasteners prior to tightening.

Safe Torques

Please refer to safe torques defined throughout this guide. If power tools are required, Clenergy recommends the use of low speed only. High speed and impact drivers increase the risk of bolt galling (deadlock). If deadlock occurs and you need to cut fasteners, please make sure that there is no load on the fastener before you cut it. Avoid damaging the anodized or galvanized surfaces.

Installation Instructions

Installation Dimensions

All drawings and dimensions in this installation guide are a generic reference only. The PV-ezRack® ComT is to be optimized to suit specific conditions for each project and documented in engineering drawings. As a result, major components of the PV-ezRack® ComT may be provided in sectional sizes and lengths that vary from those shown in this guide. The installation operations detailed in this instruction guide remain the same regardless of the component size. In the case that any on-site modification or alteration of the system is needed please provide marked up drawings/sketches for Clenergy’s review prior to modification for comment and approval.

1. Tin Interface with ECO Rail Installation

When using the Tin Interface (ER-I-05 as an example) with ECO Rail solution, please follow the steps below.

1) Fix the Tin Interface on the metal purlin with a self-tapping screw (Clenergy Tin interface is equipped with one Buildex 14-11 x 70 Hex Head Zips screw) according to the installation plan. Ensure that the Tin Interface in the front and rear or left and right directions are aligned using string as shown in Figure 1.

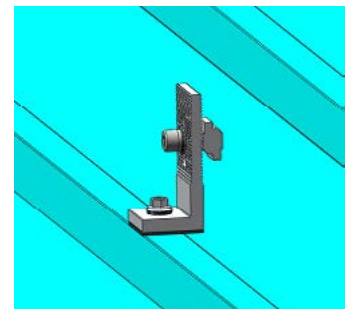

Figure 1

2) Fix the Rail on the Tin Interface as shown in Figure 2.

Recommended torques:

M8 Bolt:18-20N·m

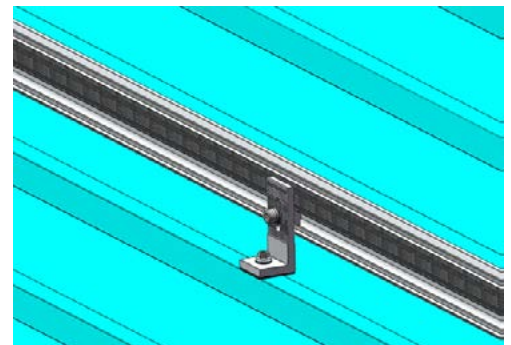
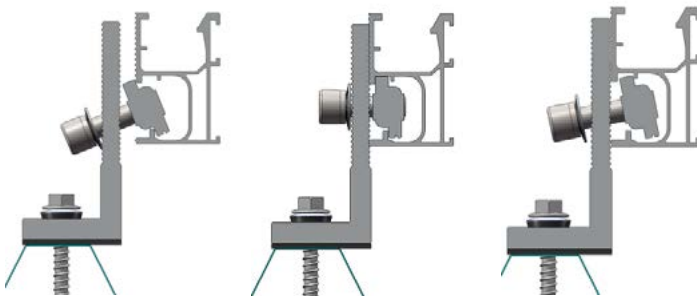

Figure 2



3) To connect several rails together, slide half of the splice into the rear side of the rail. Fasten the first M8 Bolt using an Allen key, and slide the next rail into the splice as shown in Figure 3. Tighten the second M8 Bolt using an Allen key. The total rail length is recommended not to be over 30 meters considering rails thermal expansion problem.

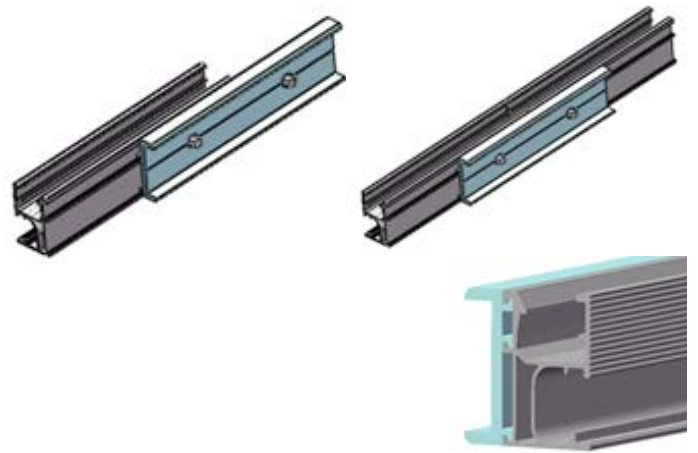

Figure 3

M8 Bolt Recommended torque is 10 ~12 N·m.

Splice provides the electrical connection between the 2 rails through the pressure bolts. This eliminates the need of using 2 earthing lugs. In case of large purlin spacing, MT-Rail Support with T50 or T110 Rail will be an option. Please follow the steps below.

2. MT-Rail Support with T50/T110 Rail Installation (optional)

In case of large purlin spacing, MT-Rail Support with T50 or T110 Rail will be an option. Please follow the steps below.

1) Based on the rib spacing of metal roof sheet, mark out the positions of self-tapping screws (Clenergy 240 mm long MT rail section is equipped with two Buildex 14-11 x 70 Hex Head Zips screws) on the MT-Rail Support and then attach the glued EPDM rubber pad under the MT-Rail Support as shown in Figure 4.

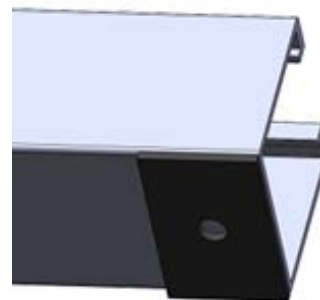

Figure 4

2) Confirm the position of the purlin for the MT-Rail Support installation, then fix the MT-Rail Support through two ribs on the purlin as shown in Figure 5.



Figure 5

3) Fix the Rail onto the MT-Rail Support with T-Rail Clamps as shown in Figure 6 and 7.

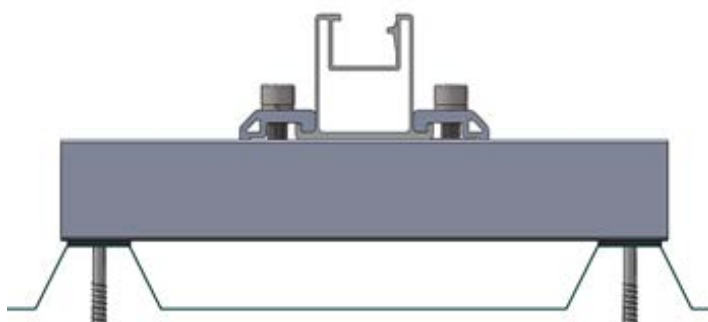

Figure 6

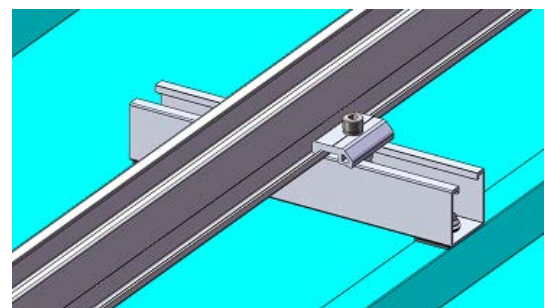

Figure 7

4) If the T Rail is not long enough, please apply Splice for T Rail to connect two T Rails together. Insert half of Splice into T Rail and fasten with two sets of Self-tapping screws in each side of T Rail, and then insert the other Splice into T Rail and fasten with Self-tapping screws as shown in Figure 8.

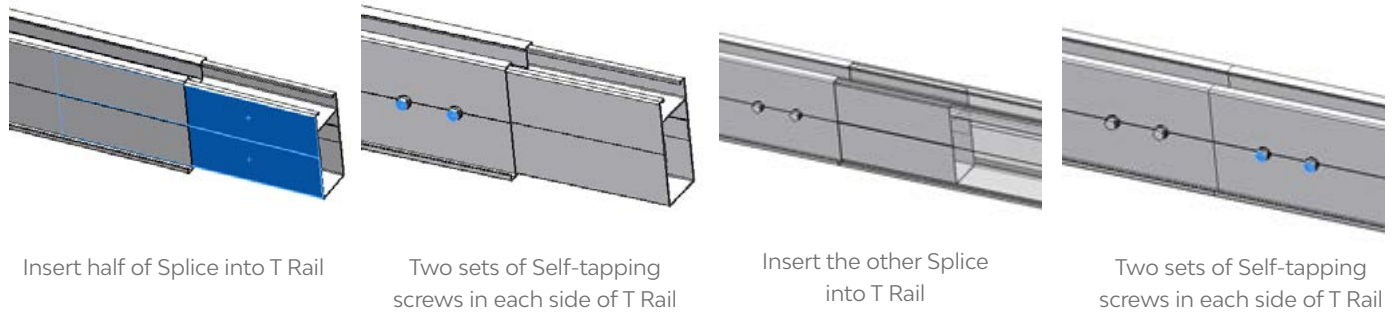

Figure 8

Note: Please fasten the Self-tapping screw until its rubber washer attach the T Rail tightly.

3. Front and Rear Leg Installation

In this step, the Tin Interface with ECO Rail is used as an example.

1) Fix the Front Leg into the top channel of ECO Rail, then fasten the Front Leg after the position is adjusted properly as shown in Figure 9 and 10.

Recommended torques:
M8 Bolt:16-20N·m.

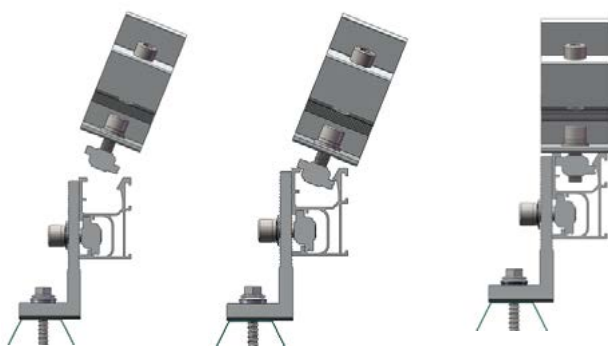

Figure 9

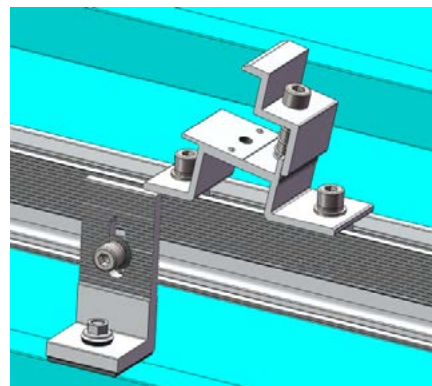

Figure 10

2) Fix the Rear Leg into the top channel of ECO Rail, then fasten the Rear Leg after the position is adjusted properly as shown in Figure 11 and 12.

Recommended torques:
M8 Bolt:16-20N·m

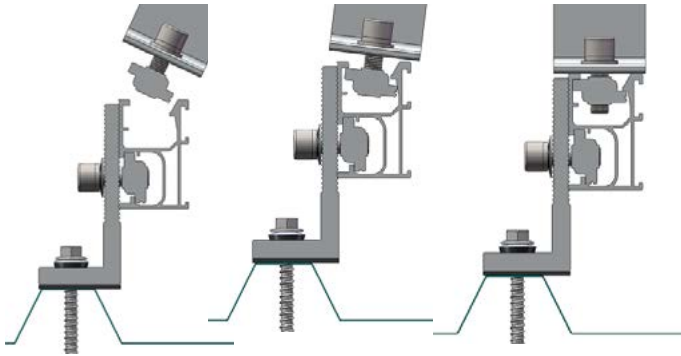

Figure 11

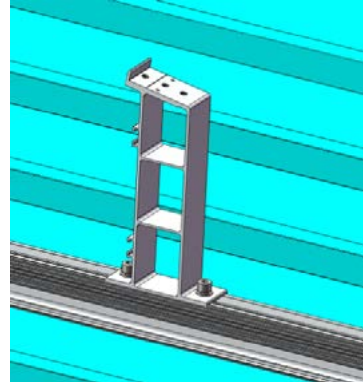

Figure 12

The Front and Rear Leg are complete as shown in Figure 13.

Note: for the Rear Leg installation, either use Clenergy provided 6mm ball head driving socket (55 mm long) or normal Hexagonal head driving socket and extension to fasten bolts.

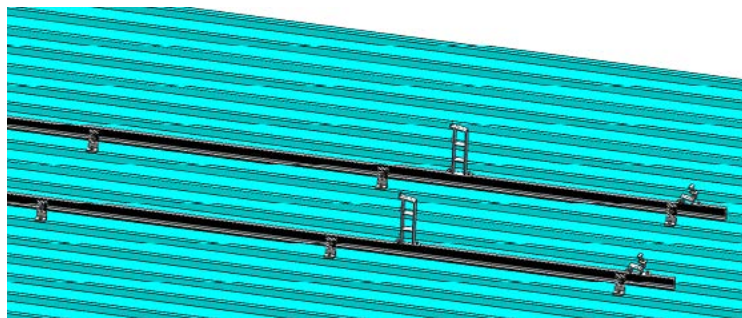

Figure 13

4. MT-rail Cable Tray Installation (optional)

The installation instruction below is to take ECO Rail as an example, the installation instruction of T-rail is the similar.

1) According to the installation plan and MT-rail cable tray load vs. span data below, mark fixing positions of Cable Tray on top of ECO rail.

Load vs. span data:

LOAD PER METER	
2.5m	38 kg
2.0m	59 kg
1.5m	106 kg
1.0m	239 kg



Figure 14

2) Insert the Z module with bolt (EZ-Z-STBW) into the slot hole of Cable Tray for each fixing point, as shown in Figure 15.

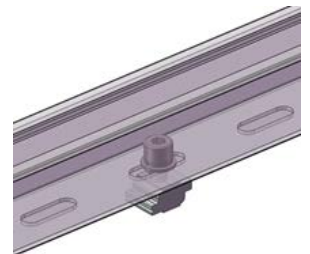

Figure 15

3) Position the Cable Tray on the top of ECO Rail by installing z module into the top channel as shown in Figure 16. Leave z module untighten.

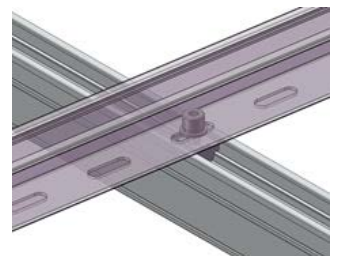

Figure 16

4) Insert the Ground Clip (EZ-GC-ST) between Cable Tray and ECO Rail for each fixing point, as shown in Figure 17.

Note: when using cutter rail (mill finish ECO rail), grounding clip is

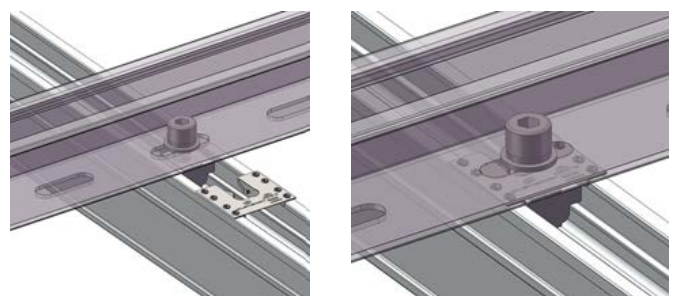

Figure 17

5) Fasten all M8 bolts with the recommended torque of 15-17N.m.

Note: Check the electrical resistance between ECO rail and cable tray to ensure the bonding is made.

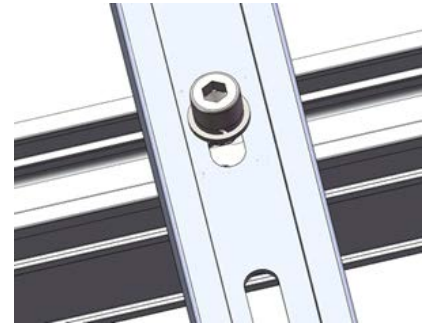

Figure 18

6) Align and click MT-rail cable tray cover in as showed in Figure 19.

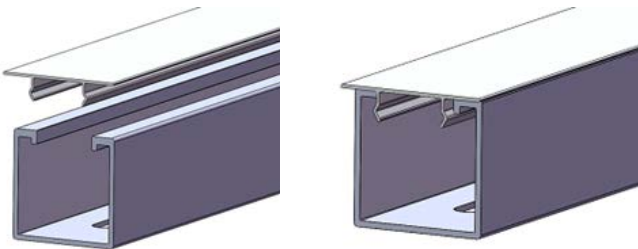

Figure 19

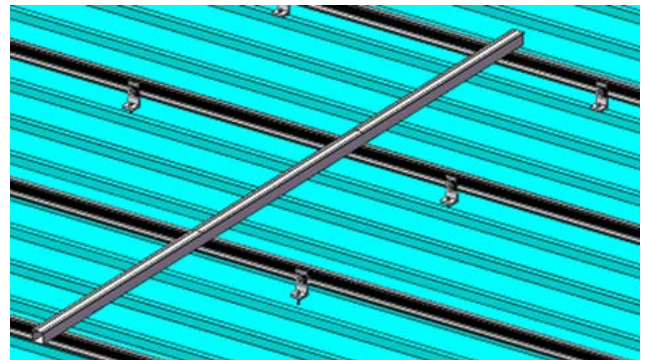

Figure 20

5. PV Module Installation

1) Place the PV Modules on the Front and Rear Leg as shown Figure 21. The outside edge of the frame of the PV Modules must overlap the marking lines on the Front and Rear Legs as shown in Figure 22. The pins of Front and Rear legs are used for creating earthing continuity from PV modules to both legs.

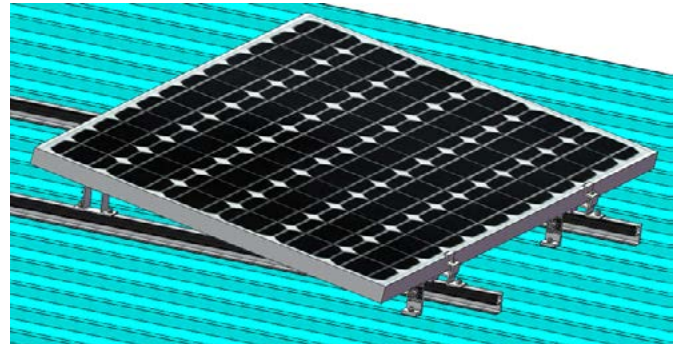

Figure 21

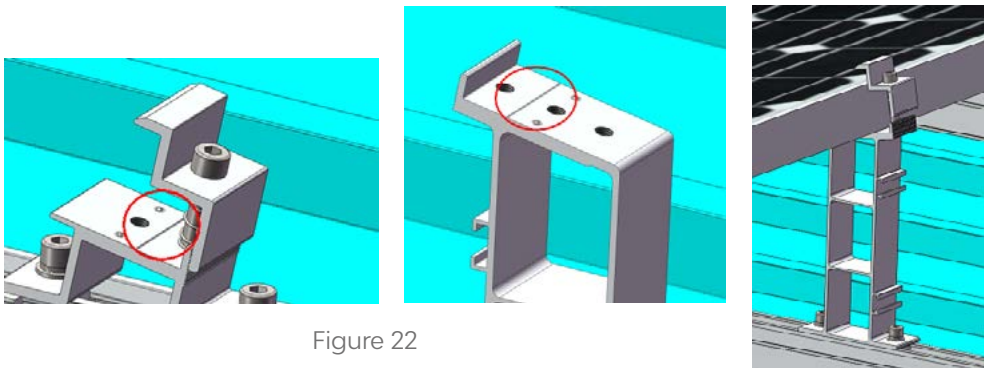

Figure 22

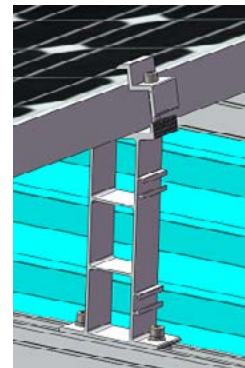

Figure 23

2) Fix the clamp on the Rear Leg shown in Figure 23 and fasten the clamps of Front and Rear legs till the PV Modules are properly installed in Figure 24.

Recommended torques:

M8 Bolt:16-20N·m

3) Repeat the above steps to install other Front and Rear Legs, and PV modules.



Figure 24

6. Grounding System Installation

Apply one pre-assembled Grounding Lug per Rail. Slide the Grounding Lug into to the rail channel and fasten the bolt M8*25 with 16~20 N·m. Strip earthing cable (the maximum size is 10 mm²) and insert the conductor into the provided copper tube. Place the copper tube into the channel of Grounding Lug and tighten M6*10 with 5~6 N·m to ensure the earthing cable is tight.

Note: Check the electrical resistance between rail and earthing cable conductor to ensure the bonding is made.

There are two solutions for Grounding Lug installation:

- Solution 1

Fix the Grounding Lug into the top channel of Rail as shown in the figure 25.

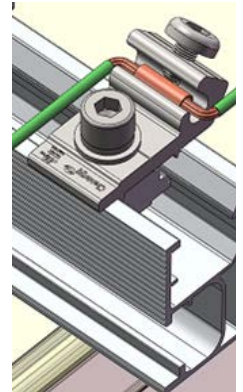

Figure 25

- Solution 2

Fix the Grounding Lug at the side channel of Rail as shown in the figure 26.



Figure 26

Certification



CIVIL & STRUCTURAL ENGINEERS
RESIDENTIAL - INDUSTRIAL - COMMERCIAL - PRODUCT DEVELOPMENT

info@mwengineering.melbourne
Phone: 1300 MWENG-0 (1300 69364-0)
www.mwengineering.melbourne
ABN 37 605 815 585

07 July 2020

Clenergy Australia
1/10 Duerdin Street
Clayton, VIC 3168

CERTIFICATION LETTER

Clenergy PV ez-Rack Commercial Tilt Certification – TC2, 2.5, 3 – Wind Region A, B, C, D. Internal REF: **00150-REVB.**

MW Engineering Melbourne, being Structural Engineers within the meaning of Australian regulations, have calculated the maximum spacings for the PV ez-Rack rail system for the following conditions:

- **Wind Loads to AS 1170.2-2011 AMDT 4-2016**
 - o Wind Terrain Category 2, 2.5 and 3
 - o Wind average recurrence of 500 years
 - o Wind Region A, B, C, D
- **Solar panel length up to 2.2 m**
- **Solar panel width up to 1.2 m**

Attached are the tables showing the spacings according to Wind Region, roof pitch, and building height.

The values shown on these tables will be valid unless an amendment is issued on any of the following codes:

- | | |
|-----------------------------------|--------------------|
| - AS/NZS 1170.0- 2002 AMDT 4-2016 | General Principles |
| - AS/NZS 1170.1- 2002 AMDT 4-2016 | Imposed Loadings |
| - AS/NZS 1170.2- 2011 AMDT 4-2016 | Wind Loadings |
| - AS/NZS 1664.1- 1997 AMDT 1:1999 | Aluminium Code |
| - AS/NZS 1252.2-2016 | Bolting |

Should you have any queries, do not hesitate to contact us.

Best Regards,



Alberto Escobar
Civil/Structural Engineer
BEng MIEAust NER
BRP EC 46542
RPEQ 18759
info@mwengineering.melbourne

July 2020



CIVIL & STRUCTURAL ENGINEERS
RESIDENTIAL - INDUSTRIAL - COMMERCIAL - PRODUCT DEVELOPMENT
info@mwengineering.melbourne
Phone: 1300 MWENG-0 (1300 69364-0)
www.mwengineering.melbourne
ABN 37 605 815 585

STRUCTURAL DESIGN CERTIFICATION

PV-ezRack® Commercial Tilt Spacing Tables According to AS/NZS 1170.2:2011 Amdt 4-2016 Within Australia Terrain Category 2, 2.5 & 3

Client: Clenergy Australia

REF: 00150-REVB

Date: 06/07/2020

Copyright: The concepts and information contained in this document are the property of MW Engineering Melbourne. Use or copying of this document in whole or in part without the written permission of MW Engineering Melbourne constitutes an infringement in copyright.

Limitation: This report has been prepared for the exclusive use of Clenergy Australia, and is subject to and issued in connection with the provisions of the agreement between MW Engineering Melbourne and Clenergy Australia. MW Engineering Melbourne accepts no liability or responsibility whatsoever for any use of or reliance upon this report by any third party other than Clenergy's clients.

July 2020



CIVIL & STRUCTURAL ENGINEERS
RESIDENTIAL - INDUSTRIAL - COMMERCIAL - PRODUCT DEVELOPMENT

info@mwengineering.melbourne
Phone: 1300 MWENG-0 (1300 69364-0)
www.mwengineering.melbourne
ABN 37 605 815 585

REF: 00150

Client: Clenergy Australia

Project: PV ez-Rack Commercial Tilt Spacing table

Australian Standards

AS/NZS 1170.0:2002 (R2016)
AS/NZS 1170.1:2002 (R2016)
AS/NZS 1170.2:2011 (R2016)
AS/NZS 1252.2:2016
AS/NZS 1664.1:1997-Amdt 1:1999

General Principles
Imposed loadings
Wind Loadings
Bolting
Aluminium

Wind Terrain Category: 2, 2.5 & 3

Designed: AE

Date: JUL 20

Disclaimer: From the date of publication onwards, any amendment made to any of the above mentioned Standards will make this report outdated and a new one will have to be released, unless the amendment has no implications on this certificate.

July 2020



CIVIL & STRUCTURAL ENGINEERS
RESIDENTIAL - INDUSTRIAL - COMMERCIAL - PRODUCT DEVELOPMENT

info@mwengineering.melbourne
Phone: 1300 MWENG-0 (1300 69364-0)
www.mwengineering.melbourne
ABN 37 605 815 585

PV ez-Rack Commercial Tilt spacing Table I.1

Type of Rail ER-R-ECO (ECO Rail) and all other ECO rails
Type of Interface ER-I-05 (Tin Interface)
Solar Panel Dimension 2 m x 1 m
Purlin Thickness 1.9 mm

Roof Angle - $0^\circ < \alpha \leq 10^\circ$

TC BUILDING HEIGHT	3					2.5					2				
	≤ 5	5<H≤10	10<H≤15	15<H≤20	20<H≤30	≤ 5	5<H≤10	10<H≤15	15<H≤20	20<H≤30	≤ 5	5<H≤10	10<H≤15	15<H≤20	20<H≤30
WRA	1.97	1.97	1.82	1.71	1.62	1.87	1.76	1.66	1.60	1.53	1.78	1.62	1.54	1.50	1.45
WRB	1.62	1.62	1.52	1.45	1.38	1.55	1.49	1.41	1.37	1.31	1.49	1.38	1.33	1.29	1.26
WRC	1.37	0.97	0.91	0.58	0.56	1.32	0.89	0.86	0.55	0.53	1.28	0.83	0.80	0.52	0.51
WRD	0.80	0.80	0.51	0.49	0.46	0.77	0.74	0.48	0.46	0.45	0.75	0.70	0.45	0.44	0.43

Note: The above spacings are for Internal Zone. Refer to Note 15 for Intermediate, Edge and Corner Zones.

July 2020



CIVIL & STRUCTURAL ENGINEERS
RESIDENTIAL - INDUSTRIAL - COMMERCIAL - PRODUCT DEVELOPMENT

info@mwengineering.melbourne
Phone: 1300 MWENG-0 (1300 69364-0)
www.mwengineering.melbourne
ABN 37 605 815 585

PV ez-Rack Commercial Tilt spacing Table I.2

Type of Rail ER-R-ECO (ECO Rail) and all other ECO rails
Type of Interface ER-I-05 (Tin Interface)
Solar Panel Dimension 2 m x 1 m
Purlin Thickness 1.9 mm

Roof Angle - $10^\circ < \alpha \leq 20^\circ$

TC BUILDING HEIGHT	3					2.5					2				
	≤ 5	5<H≤10	10<H≤15	15<H≤20	20<H≤30	≤ 5	5<H≤10	10<H≤15	15<H≤20	20<H≤30	≤ 5	5<H≤10	10<H≤15	15<H≤20	20<H≤30
WRA	1.21	1.21	1.15	1.11	1.05	1.17	1.13	1.08	1.04	1.01	1.13	1.05	1.02	1.00	0.97
WRB	1.02	1.02	0.96	0.93	0.89	0.98	0.95	0.91	0.88	0.86	0.95	0.89	0.86	0.85	0.82
WRC	0.89	0.59	0.56	0.36	0.34	0.86	0.55	0.53	0.34	0.30	0.83	0.52	0.47	0.29	0.27
WRD	0.46	0.46	0.26	0.24	0.21	0.41	0.37	0.22	0.20	0.18	0.38	0.31	0.19	0.18	0.16

Note: The above spacings are for Internal Zone. Refer to Note 15 for Intermediate, Edge and Corner Zones.

July 2020



CIVIL & STRUCTURAL ENGINEERS
 RESIDENTIAL - INDUSTRIAL - COMMERCIAL - PRODUCT DEVELOPMENT
 info@mwengineering.melbourne
 Phone: 1300 MWENG-0 (1300 69364-0)
 www.mwengineering.melbourne
 ABN 37 605 815 585

PV ez-Rack Commercial Tilt spacing Table I.3

Type of Rail ER-R-ECO (ECO Rail) and all other ECO rails
 Type of Interface ER-I-05 (Tin Interface)
 Solar Panel Dimension 2 m x 1 m
 Purlin Thickness 1.9 mm

Roof Angle - $20^\circ < \alpha \leq 30^\circ$

TC BUILDING HEIGHT	3					2.5					2				
	≤ 5	5<H≤10	10<H≤15	15<H≤20	20<H≤30	≤ 5	5<H≤10	10<H≤15	15<H≤20	20<H≤30	≤ 5	5<H≤10	10<H≤15	15<H≤20	20<H≤30
WRA	1.07	1.07	1.02	0.98	0.93	1.04	1.00	0.96	0.93	0.90	1.00	0.93	0.90	0.88	0.86
WRB	0.90	0.90	0.86	0.82	0.71	0.87	0.84	0.76	0.70	0.63	0.84	0.71	0.64	0.61	0.57
WRC	0.71	0.44	0.38	0.34	0.30	0.64	0.36	0.32	0.29	0.27	0.59	0.30	0.28	0.26	0.24
WRD	0.27	0.27	0.23	0.21	0.19	0.25	0.22	0.20	0.18	0.17	0.22	0.19	0.17	0.16	0.15

Note: The above spacings are for Internal Zone. Refer to Note 15 for Intermediate, Edge and Corner Zones.

July 2020



CIVIL & STRUCTURAL ENGINEERS
RESIDENTIAL - INDUSTRIAL - COMMERCIAL - PRODUCT DEVELOPMENT

info@mwengineering.melbourne
Phone: 1300 MWENG-0 (1300 69364-0)
www.mwengineering.melbourne
ABN 37 605 815 585

PV ez-Rack Commercial Tilt spacing Table 2.1

Type of Rail ER-R-T50
Type of Interface S-MT/240 (MT – Rail support)
Solar Panel Dimension 2 m x 1 m
Purlin Thickness 1.9 mm

Roof Angle - $0^\circ < \alpha \leq 10^\circ$

TC BUILDING HEIGHT	3					2.5					2				
	≤ 5	5<H≤10	10<H≤15	15<H≤20	20<H≤30	≤ 5	5<H≤10	10<H≤15	15<H≤20	20<H≤30	≤ 5	5<H≤10	10<H≤15	15<H≤20	20<H≤30
WRA	2.31	2.31	2.13	2.01	1.89	2.19	2.07	1.94	1.87	1.79	2.08	1.89	1.81	1.76	1.70
WRB	1.81	1.81	1.69	1.61	1.53	1.73	1.65	1.57	1.52	1.47	1.66	1.53	1.47	1.44	1.40
WRC	1.53	1.13	1.07	0.68	0.65	1.47	1.04	1.00	0.65	0.62	1.42	0.98	0.94	0.62	0.60
WRD	0.94	0.94	0.59	0.57	0.54	0.91	0.87	0.56	0.54	0.52	0.88	0.82	0.52	0.52	0.50

Note: The above spacings are for Internal Zone. Refer to Note 15 for Intermediate, Edge and Corner Zones.

July 2020



CIVIL & STRUCTURAL ENGINEERS
RESIDENTIAL - INDUSTRIAL - COMMERCIAL - PRODUCT DEVELOPMENT

info@mwengineering.melbourne
Phone: 1300 MWENG-0 (1300 69364-0)
www.mwengineering.melbourne
ABN 37 605 815 585

PV ez-Rack Commercial Tilt spacing Table 2.1

Type of Rail ER-R-T50
Type of Interface S-MT/240 (MT – Rail support)
Solar Panel Dimension 2 m x 1 m
Purlin Thickness 1.9 mm

Roof Angle - $10^\circ < \alpha \leq 20^\circ$

TC BUILDING HEIGHT	3					2.5					2				
	≤ 5	5<H≤10	10<H≤15	15<H≤20	20<H≤30	≤ 5	5<H≤10	10<H≤15	15<H≤20	20<H≤30	≤ 5	5<H≤10	10<H≤15	15<H≤20	20<H≤30
WRA	1.35	1.35	1.28	1.23	1.18	1.31	1.26	1.20	1.17	1.13	1.26	1.18	1.14	1.11	1.08
WRB	1.14	1.14	1.08	1.04	1.00	1.10	1.06	1.01	0.99	0.95	1.07	1.00	0.96	0.95	0.92
WRC	0.99	0.69	0.66	0.42	0.40	0.96	0.65	0.62	0.40	0.38	0.93	0.60	0.57	0.37	0.36
WRD	0.57	0.57	0.35	0.33	0.31	0.54	0.52	0.32	0.31	0.30	0.52	0.47	0.30	0.29	0.28

Note: The above spacings are for Internal Zone. Refer to Note 15 for Intermediate, Edge and Corner Zones.

July 2020



CIVIL & STRUCTURAL ENGINEERS
RESIDENTIAL - INDUSTRIAL - COMMERCIAL - PRODUCT DEVELOPMENT

info@mwengineering.melbourne
Phone: 1300 MWENG-0 (1300 69364-0)
www.mwengineering.melbourne
ABN 37 605 815 585

PV ez-Rack Commercial Tilt spacing Table 2.3

Type of Rail ER-R-T50
Type of Interface S-MT/240 (MT – Rail support)
Solar Panel Dimension 2 m x 1 m
Purlin Thickness 1.9 mm

Roof Angle - $20^\circ < \alpha \leq 30^\circ$

TC BUILDING HEIGHT	3					2.5					2				
	≤ 5	5<H≤10	10<H≤15	15<H≤20	20<H≤30	≤ 5	5<H≤10	10<H≤15	15<H≤20	20<H≤30	≤ 5	5<H≤10	10<H≤15	15<H≤20	20<H≤30
WRA	1.27	1.27	1.21	1.16	1.11	1.23	1.18	1.13	1.10	1.06	1.19	1.11	1.07	1.05	1.02
WRB	1.07	1.07	1.02	0.98	0.91	1.03	0.99	0.94	0.90	0.86	1.00	0.91	0.87	0.84	0.81
WRC	0.91	0.56	0.52	0.33	0.31	0.87	0.50	0.47	0.30	0.29	0.83	0.46	0.44	0.28	0.27
WRD	0.44	0.44	0.27	0.26	0.24	0.41	0.40	0.25	0.24	0.22	0.40	0.36	0.22	0.21	0.20

Note: The above spacings are for Internal Zone. Refer to Note 15 for Intermediate, Edge and Corner Zones.

July 2020



CIVIL & STRUCTURAL ENGINEERS
RESIDENTIAL - INDUSTRIAL - COMMERCIAL - PRODUCT DEVELOPMENT

info@mwengineering.melbourne
Phone: 1300 MWENG-0 (1300 69364-0)
www.mwengineering.melbourne
ABN 37 605 815 585

PV ez-Rack Commercial Tilt spacing Table 3.1

Type of Rail ER-R-T110
Type of Interface S-MT/240 (MT – Rail support)
Solar Panel Dimension 2 m x 1 m
Purlin Thickness 1.9 mm

Roof Angle - $0^\circ < \alpha \leq 10^\circ$

TC BUILDING HEIGHT	3					2.5					2				
	≤ 5	5<H≤10	10<H≤15	15<H≤20	20<H≤30	≤ 5	5<H≤10	10<H≤15	15<H≤20	20<H≤30	≤ 5	5<H≤10	10<H≤15	15<H≤20	20<H≤30
WRA	3.64	3.64	3.36	3.17	2.98	3.44	3.26	3.07	2.95	2.82	3.28	2.98	2.85	2.78	2.68
WRB	2.84	2.84	2.67	2.55	2.42	2.72	2.61	2.48	2.40	2.31	2.62	2.42	2.32	2.27	2.21
WRC	2.41	2.23	2.10	1.34	1.28	2.32	2.06	1.96	1.27	1.22	2.24	1.92	1.85	1.21	1.17
WRD	1.84	1.84	1.16	1.12	1.07	1.78	1.71	1.09	1.06	1.02	1.72	1.60	1.03	1.01	0.98

Note: The above spacings are for Internal Zone. Refer to Note 15 for Intermediate, Edge and Corner Zones.

July 2020



CIVIL & STRUCTURAL ENGINEERS
RESIDENTIAL - INDUSTRIAL - COMMERCIAL - PRODUCT DEVELOPMENT

info@mwengineering.melbourne
Phone: 1300 MWENG-0 (1300 69364-0)
www.mwengineering.melbourne
ABN 37 605 815 585

PV ez-Rack Commercial Tilt spacing Table 3.2

Type of Rail ER-R-T110
Type of Interface S-MT/240 (MT – Rail support)
Solar Panel Dimension 2 m x 1 m
Purlin Thickness 1.9 mm

Roof Angle - $10^\circ < \alpha \leq 20^\circ$

TC BUILDING HEIGHT	3					2.5					2				
	≤ 5	5<H≤10	10<H≤15	15<H≤20	20<H≤30	≤ 5	5<H≤10	10<H≤15	15<H≤20	20<H≤30	≤ 5	5<H≤10	10<H≤15	15<H≤20	20<H≤30
WRA	2.19	2.19	2.08	2.00	1.91	2.12	2.04	1.95	1.90	1.83	2.04	1.91	1.84	1.80	1.76
WRB	1.84	1.84	1.75	1.65	1.55	1.78	1.70	1.60	1.53	1.46	1.71	1.55	1.47	1.43	1.37
WRC	1.54	1.30	1.21	0.86	0.77	1.46	1.18	1.10	0.76	0.69	1.40	1.03	0.94	0.66	0.62
WRD	0.92	0.92	0.60	0.54	0.47	0.83	0.75	0.50	0.46	0.42	0.76	0.63	0.43	0.41	0.37

Note: The above spacings are for Internal Zone. Refer to Note 15 for Intermediate, Edge and Corner Zones.

July 2020



CIVIL & STRUCTURAL ENGINEERS
RESIDENTIAL - INDUSTRIAL - COMMERCIAL - PRODUCT DEVELOPMENT

info@mwengineering.melbourne
Phone: 1300 MWENG-0 (1300 69364-0)
www.mwengineering.melbourne
ABN 37 605 815 585

PV ez-Rack Commercial Tilt spacing Table 3.3

Type of Rail ER-R-T110
Type of Interface S-MT/240 (MT – Rail support)
Solar Panel Dimension 2 m x 1 m
Purlin Thickness 1.9 mm

Roof Angle - $20^\circ < \alpha \leq 30^\circ$

TC BUILDING HEIGHT	3					2.5					2				
	≤ 5	5<H≤10	10<H≤15	15<H≤20	20<H≤30	≤ 5	5<H≤10	10<H≤15	15<H≤20	20<H≤30	≤ 5	5<H≤10	10<H≤15	15<H≤20	20<H≤30
WRA	1.81	1.81	1.71	1.61	1.51	1.75	1.66	1.56	1.50	1.42	1.67	1.51	1.43	1.39	1.34
WRB	1.43	1.43	1.33	1.21	1.07	1.36	1.28	1.13	1.04	0.94	1.29	1.07	0.96	0.91	0.84
WRC	1.05	0.89	0.77	0.63	0.56	0.96	0.73	0.65	0.54	0.50	0.87	0.61	0.55	0.47	0.44
WRD	0.54	0.54	0.43	0.39	0.34	0.49	0.44	0.36	0.34	0.30	0.45	0.37	0.31	0.29	0.27

Note: The above spacings are for Internal Zone. Refer to Note 15 for Intermediate, Edge and Corner Zones.

July 2020



CIVIL & STRUCTURAL ENGINEERS
 RESIDENTIAL - INDUSTRIAL - COMMERCIAL - PRODUCT DEVELOPMENT
 info@mwengineering.melbourne
 Phone: 1300 MWENG-0 (1300 69364-0)
 www.mwengineering.melbourne
 ABN 37 605 815 585

General Notes

Note 1: Standard screws shipped for Tin Roof Interfaces

Metal Purlins/Battens	Fasteners to use
0.75 mm	Buildex- 14 - 11 x 70 Hex Head Zips Climaseal 3 with 16 mm ABW on G550 Steel Battens
1.9 mm - 2.4 mm	Buildex- 14 - 11 x 70 Hex Head Zips Climaseal 3 with 16 mm ABW
Wood Purlins and Rafters	Fasteners to be used
Timber F7 (Pine) and Timber I7 (Hardwood). 25 mm, 30 mm and 35 mm embedment	Buildex- 14 - 11 x 70 Hex Head Zips Climaseal 3 with 16 mm ABW or 14g (6.3 mm)

Note 2: Tin spacings were calculated based on Steel Purlins G450 1.9mm.

Note 3. This Engineering Document was designed to cater for most common installation scenarios however, it does not cater for all of them. Contact Clenergy if you are unable to comply with any of the installation specifications listed on this document.

Note 4. The following components are satisfied for use according to AS/NZS 1664.1:1997-Amdt 1:1999 and AS/NZS 1170.2:2011 Amdt 4-2016.

Components	Part No.	Description
ECO-Rail	ER-R-ECO/XXXX	ECO Rail
Splice	ER-SP-ECO	PV-ezRack Splice for ECO rail
Australian Made Mill Finish ECO Rail	R-ECO/XXXX/AUMF	PV-ezRack Australian Made Mill Finish ECO Rail
ST-Rail	ER-R-STXXXX	Standard Rail
Splice	ER-SP-ST	PV-ezRack Splice for Standard Rail 200mm
T50 Rail	ER-R-T50/XXXX	T50 Rail

July 2020

CIVIL & STRUCTURAL ENGINEERS
 RESIDENTIAL - INDUSTRIAL - COMMERCIAL - PRODUCT DEVELOPMENT

info@mwengineering.melbourne
 Phone: 1300 MWENG-0 (1300 69364-0)
 www.mwengineering.melbourne
 ABN 37 605 815 585

Components	Part No.	Description
Splice	ER-SP-T50	PV-ezRack Splice for T50 rail
T110 Rail	ER-R-T110/XXXX	T110 Rail
Slice	ER-SP-T110	PV-ezRack Splice for T110 rail
MT Rail Section	S-MT/XXXX	MT support
Rail Clamp	ER-RC-T/DM	Rail clamp for T-rail with diamond module
Rail Clamp	ER-RC-T/G	Rail clamp for T-rail with Z module
Diamond Module	ER-DM-MT8	Diamond module
Front Leg	FL/COMT/Z/G/10	Front leg, commercial tilt 10 degree
Back Leg	RL/COMT/Z/G/10	Back leg, commercial tilt 10 degree
Interface	ER-I-05	Tin Interface
Interface	ER-I-05/BA	Tin Interface Black
Interface	ER-I-05/CM	Tin Interface with Click Module
Interface	ER-I-05A/EZC/ECO	ezClick connection for ECO-Rail
Interface	ER-I-25	Tin Interface with curved Base for corrugated Roof

July 2020



CIVIL & STRUCTURAL ENGINEERS
RESIDENTIAL - INDUSTRIAL - COMMERCIAL - PRODUCT DEVELOPMENT

info@mwengineering.melbourne
Phone: 1300 MWENG-0 (1300 69364-0)
www.mwengineering.melbourne
ABN 37 605 815 585

Components	Part No.	Description
Adapter for Corrugated Roof	EZ-AD-C43	Adapted for Corrugated Iron Roof for Tin interface ER-I-05
Corrugated Adapter	EZ-AD-C110	PV-ezRack Adapter for Corrugated Iron Roof.
Connector Clamp	CRC-R/ECO	Cross Connector Clamp for ECO-Rail
Hanger Bolt	ER-HB-MP/8/150EP	PV-ezRack Hanger Bolt for metal purlin M8*150mm
ECO Rail Black	ER-R-ECO/XXXX/BA	ECO Rail Black
Splice ECO Rail Black	ER-SP-ECO/BA	Splice ECO Rail Black
Front Leg	FL-COMT/Z/G/10/BA	Front Leg, commercial tilt 10 degree (black anodized)
Rear Leg	RL-COMT/Z/G/10/BA	Rear Leg, commercial tilt 10 degree (black anodized)
MT rail section	S-MT/XXXX/BA	MT rail support (black anodized)
Rail Clamp	ER-RC-T/DM/BA	Rail clamp for T-rail with diamond module (black anodized)

Note 5. For Terrain Category (TC) definition, please refer to clause 4.2.1 of AS/NZS 1170.2:2011 (R2016).

Note 6. The installed frame must comply with the clamping zone of the PV Panel.

Note 7. Capacities checked and compared against testing data from Clenergy Australia and MTS (NATA certified).

Note 8. Maximum permitted rail overhang of 40%.

Note 9. From the date of publication onwards, any amendment made to any of the above mentioned Standards will make this report outdated and a new one will have to be released, unless the amendment has no implications on this certificate.

July 2020



CIVIL & STRUCTURAL ENGINEERS
 RESIDENTIAL - INDUSTRIAL - COMMERCIAL - PRODUCT DEVELOPMENT
 info@mwengineering.melbourne
 Phone: 1300 MWENG-0 (1300 69364-0)
 www.mwengineering.melbourne
 ABN 37 605 815 585

Note 10. No consideration has been taken on the effect that the solar panel will have over the roof structure. It has been assumed that the roof will be able to resist the additional loadings imposed by the installation of the solar panels in conjunction with the Clenergy Mounting System.

Note 11. All components from Clenergy must be installed according to manufacturer's specification and the instructions shown in the relevant installation manual. Please check the Clenergy Australia website or contact them for access to the most recent installation manuals.

Note 12. No consideration has been taken on the effect of snow loads. In case the roof is located in a snow prone area, a special design must be made.

Note 13. Minimum grade for steel purlins/battens of 450 Mpa.

Note 14. If any of the screws of the interfaces go into pre-existing holes, they will have to be one size up compared to the screws that were previously installed. This is to ensure that the pullout capacity remains the same or higher.

Note 15. Zone reduction factors to be the following:

- Intermediate: Divide table spacings by 1.5
- Edge: Divide table spacing by 2
- Corner: Divide table spacing by 3

Example: To find out a fixing spacing on the intermediate zone for a 5-meter building on wind region A, terrain category 3, roof pitch less than 10° and using ER-R-ECO rail, take the respective spacing from table 1.1 which is 1.88m and divide it by 1.5. The result would be 1.25m which would be the corresponding fixing spacing for intermediate zone for the previous scenario.

Note 16. The interface spacings are based on the solar panel row spacing of up to 400 mm. When the row spacing is over 400 mm an interface spacing increase factor of 5% can be applied. When the row spacing is over 650 mm an interface spacing increase factor of 20% can be applied.

Note 17. Minimum of two (2) screws per fixing point when using ER-R-MT rail and one for ER-R-ECO.

Note 18. If the installation is located in ISO corrosivity category C4 reduce the interface spacing by 5%. If the installation is located in ISO corrosivity category C5 reduce the interface spacing by 25%.

Note 19. Fixing spacing to be reduced on increased according to the purlin thickness as per below:

Purlin Thickness		
From 1.2mm to 1.49mm	From 1.5 mm to 1.89 mm	From 2.4 mm and above
Reduction of 60%	Reduction of 30%	Increase of 17%



CIVIL & STRUCTURAL ENGINEERS
 RESIDENTIAL - INDUSTRIAL - COMMERCIAL - PRODUCT DEVELOPMENT
 info@mwengineering.melbourne
 Phone: 1300 MWENG-0 (1300 69364-0)
 www.mwengineering.melbourne
 ABN 37 605 815 585

Note 20. Fixing spacing to be reduced to timber purlins as per below:

	Batten type		
	25 mm	30 mm	35 mm
Timber F7	Reduction of 55%	Reduction of 45%	Reduction of 40%
Timber F17	Decrease of 15%	Spacings remain the same	Increase of 15%

Note 21. This Engineering report is based on 2 m x 1 m panels and two rails per panel. However, a percentage increase can be applied on all interface spacings as shown on the following table.

Number of rails per panel	Panel length / width (mm)	Spacing +/-
2 rails	≤ 1700/ ≤ 1100	+ 8 %
3 rails	≤ 1700/ ≤ 1100	+ 12 %
2 rails	≤ 2000/ ≤ 1100	0 %
3 rails	≤ 2000/ ≤ 1100	+ 10 %
2 rails	≤ 2100/ ≤ 1100	- 10 %
3 rails	≤ 2100/ ≤ 1100	+ 6 %
2 rails	≤ 2200/ ≤ 1100	- 15 %
2 rails	≤ 2200/ ≤ 1200	- 20 %

Note 22. Roof Zone definition for tilted systems where roof angle is between 1° to 45°.

- Step 1.** Determine building height (h), width (b) and length (d).
- Step 2.** Choose the lowest value between "h", "b x 0.2" and "d x 0.2".
- Step 3.** The lowest value on Step 2, equates to a.



CIVIL & STRUCTURAL ENGINEERS
RESIDENTIAL - INDUSTRIAL - COMMERCIAL - PRODUCT DEVELOPMENT

info@mwengineering.melbourne
Phone: 1300 MWENG-0 (1300 69364-0)
www.mwengineering.melbourne
ABN 37 605 815 585

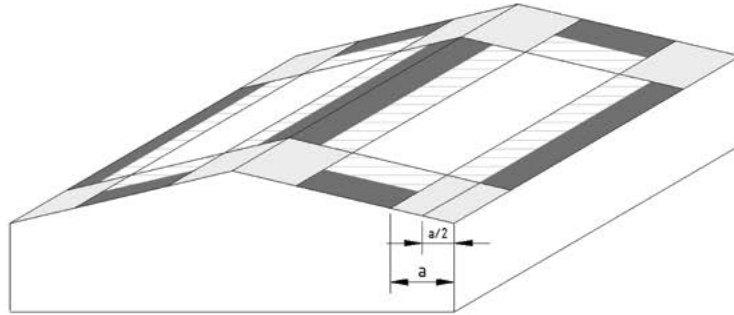

Roof Pitch < 10°

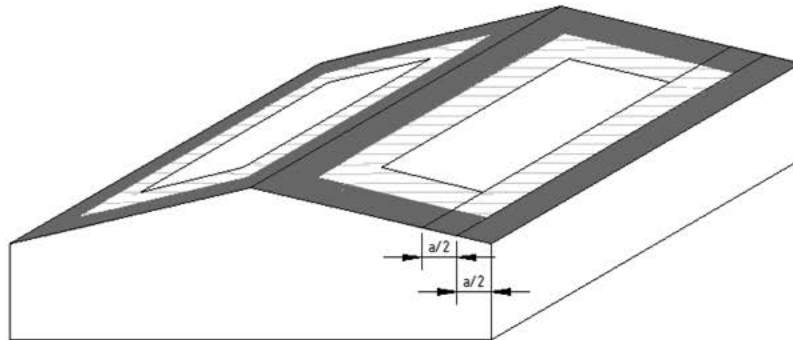

Roof Pitch ≥ 10°

Legend:

- Internal Zone
- Intermediate Zone
- Edge Zone
- Corner Zone

July 2020



CIVIL & STRUCTURAL ENGINEERS
 RESIDENTIAL - INDUSTRIAL - COMMERCIAL - PRODUCT DEVELOPMENT
 info@mwengineering.melbourne
 Phone: 1300 MWENG-0 (1300 69364-0)
 www.mwengineering.melbourne
 ABN 37 605 815 585

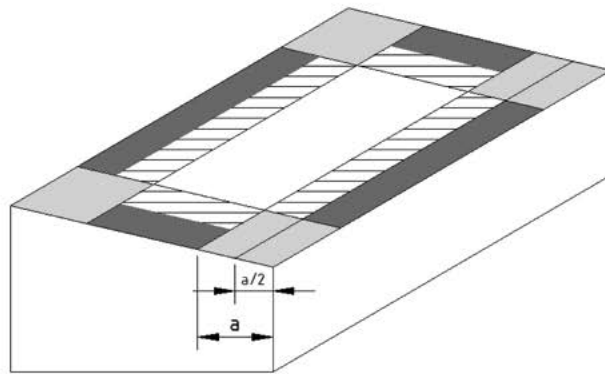



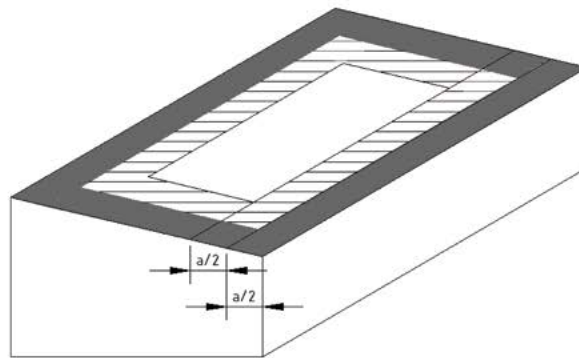

Flat/Mono – Slope Roof < 10°



Flat/Mono – Slope Roof ≥ 10°

Legend:

-  Internal Zone
-  Intermediate Zone
-  Edge Zone
-  Corner Zone

July 2020







PV-ezRACK®

Clenergy

1/10 Duerdin St
Clayton VIC 2168
Australia

Phone: +61 3 9239 8088
Email: sales@clenergy.com.au
Web: www.clenergy.com.au

 @ClenergyGlobal / @ClenergyClub / ClenergyAUS  @Clenergy  @ClenergyClub
 @Clenergy_global  @Clenergy

A Clenergy Technologies Company